



MASTERVOLT ALTERNATORS

12V AND 24V SERIES

HIGH PERFORMANCE ALTERNATORS



USER AND INSTALLATION MANUAL

TABLE OF CONTENTS

1	GENERAL INFORMATION	3	5.4	Drive belt re-installation	13
1.1	Use of this manual	3	5.4.1	With auto-tensioner pulley	13
1.2	Identification label	3	5.4.2	No auto-tensioner pulley	13
1.3	Liability	3	5.4.3	Final check	13
1.4	Warranty	4	6	Electrical Installation	14
1.5	Disclaimer	4	6.1	Precautions	14
1.6	Correct Disposal of This Product	4	6.2	Fuse	14
2	Safety Instructions	5	6.3	Wiring	14
3	System example	6	7	Commissioning	17
4	Before you start the installation	7	7.1	Preparations	17
4.1	Mounting bracket	7	7.2	Regulator configuration with MasterAdjust	17
4.2	Rotation direction	7	7.3	First operation and testing	17
4.3	Isolating bushings (Alpha Compact only)	7	7.4	Normal operation	17
4.4	Drive belt	7	8	Maintenance	18
4.5	Engine load	7	8.1	Mounting points	18
4.6	Pulleys	7	8.2	Cleaning	18
4.6.1	Pulley type selection	7	8.3	Check tension and condition of the drive belt	18
4.6.2	Pulley size selection	8	9	Troubleshooting	19
4.6.3	Calculating alternator output	8	9.1	Trouble shooting hints	19
4.6.4	Pulley alignment	8	9.2	Fault finding table	19
4.7	Pulley installation (Alpha Compact only)	9	10	Technical Data	20
4.7.1	Standard pulley	10	10.1	General specifications	20
4.7.2	Clutch pulley	10	10.2	Technical specifications	21
5	Mechanical Installation	11	10.3	Mechanical specifications – Alternators	23
5.1	Preparations	11	10.4	Mechanical specifications – Pulleys	26
5.2	Prepare mounting location	11	10.4.1	For Alpha Compact models	26
5.2.1	Main alternator upgrade	11	10.4.2	For Alpha models (12/130, 24/75, 24/110, 24/150 Evo)	26
5.2.2	Secondary alternator installation	11	10.5	Output curves	28
5.3	Alternator mounting	11			

1 GENERAL INFORMATION



WARNING!

Read the entire manual before using the Mastervolt Alternator.
Keep this manual in a secure place.

1.1 Use of this manual

A Mastervolt Alternator can be purchased individually, or as part of a kit that includes the Alpha Pro regulator and/or a pulley. This manual serves as a guideline for the safe and effective operation and maintenance of the following Mastervolt Alternator models:

- Alpha 12/130
- Alpha 24/75
- Alpha 24/110
- Alpha 24/150 Evo
- Alpha Compact 14/200
- Alpha Compact 28/110
- Alpha Compact 28/150
- Alpha Compact 14/120 for Mercedes-Benz N62
- Alpha Compact 14/200 for Mercedes-Benz N62
- Alpha Compact 28/200 for Mercedes-Benz N62
- Alpha Compact 14/140 for Volvo Penta*
- Alpha Compact 28/80 for Volvo Penta*
- Alpha Compact 28/110 for Volvo Penta*
- Alpha Compact 28/150 for Volvo Penta*

* This alternator is only compatible with Volvo Penta models D4 – D13.

These models are further referred to as “Mastervolt Alternator”.

1.2 Identification label

The following picture is only an example!

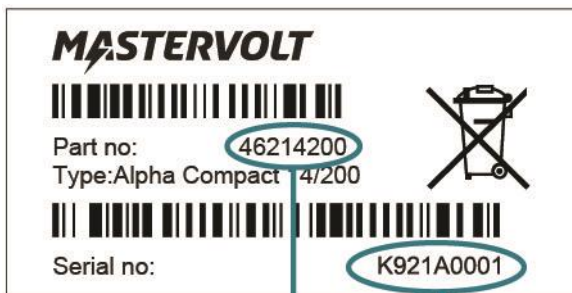

Part number

Serial number K921A0001, device version "A".

Figure 1: Identification label



CAUTION!

Important information required for service or maintenance can be derived from the identification label. Never remove the identification label. This will void the warranty.

1.3 Liability

Mastervolt can accept no liability for:

- Consequential damage resulting from the use of the Mastervolt Alternator.
- Possible errors in the included manual and the consequences of these.
- Use that is inconsistent with the purpose of the product.

1.4 Warranty

Mastervolt assures the product warranty of the Mastervolt Alternator during two years after purchase, on the condition that the product is installed and used according to the instructions in this manual.

Installation or use not according to these instructions may result in under performance, damage or failure of the product and may void this warranty. The warranty is limited to the cost of repair and/or replacement of the product. Costs of labor or shipping are not covered by this warranty.

1.5 Disclaimer

Our products are subject to continual development and improvement. Therefore, additions or modifications to the products may cause changes to the technical data and functional specifications. No rights can be derived from this document. Please consult our most current Terms & Conditions of Sale.

1.6 Correct Disposal of This Product

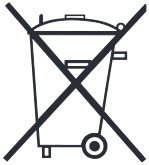

This product is designed and manufactured with high quality materials and components, which can be recycled and reused. Please be informed about the local separate collection system for electrical and electronic products. Please act according to your local rules and do not dispose of your old products with your normal household waste. The correct disposal of your old product will help prevent potential negative consequences to the environment and human health.

2 SAFETY INSTRUCTIONS

IMPORTANT SAFETY INSTRUCTIONS

SAVE THESE INSTRUCTIONS

Warnings and symbols

Safety instructions and warnings are marked in this manual and on the product by the following pictograms:



CAUTION!

Special information, commands and prohibitions in order to prevent damage.



WARNING!

A WARNING refers to possible injury to the user or installer or significant material damage to the Mastervolt Alternator if the installer / user does not (carefully) follow the stated procedures.



WARNING!

The addition of this symbol to a warning indicates that a potential hazard exists caused by moving parts.

This chapter describes important safety and operating instructions for use of a Mastervolt Alternator.

Use the Mastervolt Alternator only:

- for the charging of lead acid or Li-Ion batteries and the supply of loads connected to these batteries, in permanent systems;
- with fuses, protecting the wiring between alternator/regulator output and battery;
- in a technical correct condition;
- in a closed, well-ventilated area, protected against rain, moist, dust, condensation and (sea)water.

Warning regarding life support applications

Mastervolt products are not designed to be used as component of medical equipment, unless negotiated in the form of a written agreement between customer and/or manufacturer and Mastervolt. Such agreement will require the equipment manufacturer either to contract additional reliability testing of the Mastervolt parts and/or to commit to undertake such testing as a part of the manufacturing process. In addition, the manufacturer must agree to indemnify and not hold Mastervolt responsible for any claims arising from the use of the Mastervolt parts in the life support equipment.

Personal precautions

Remove the keys from the ignition and disconnect all batteries in the system which is being worked on.

During installation or maintenance:

- stick to tools and methods recommended in the manual;
- work in a well-ventilated area;
- wear safety glasses and remove loose fitting clothing and jewelry;
- be aware of hot surfaces: both engine parts as well as the alternator.

Working procedures

If the alternator, regulator and engine are switched off during maintenance and/or repair activities, they should be secured against unexpected and unintentional switching on.



WARNING!

When service has to be carried out while the engine is running, be aware of moving parts like V-belts.

3 SYSTEM EXAMPLE

Mastervolt Alternators can be used as main or as 2nd alternator. The following figure shows a typical example of a Mastervolt Alternator that is used as 2nd alternator in a power system. Please note that this figure is simplified and does not reflect the actual placement of all devices nor the complete connections. For each device, refer to the corresponding installation manual and follow the given instructions.

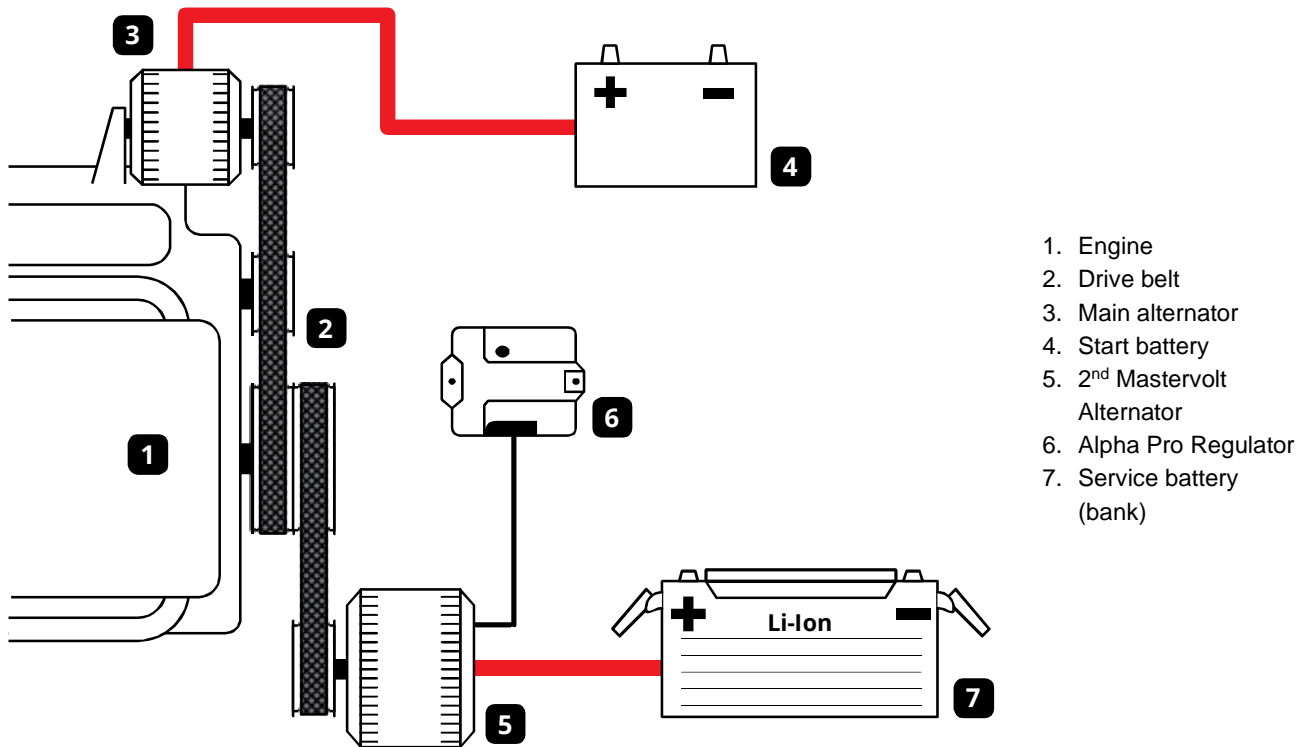

1. Engine
2. Drive belt
3. Main alternator
4. Start battery
5. 2nd Mastervolt Alternator
6. Alpha Pro Regulator
7. Service battery (bank)

Figure 2: Simplified architecture of a typical dual alternator configuration

Mastervolt Alternator

Mastervolt Alternators transform your engine into a high-power energy source for electrical on-board consumers and guarantee a quick charge of your service and starter batteries. Mastervolt Alternators are built to operate continuously under the high temperatures of an engine room and can be used either as an upgrade to the main alternator or as a secondary alternator.

Alpha Pro regulator

The Mastervolt Alternator is designed for use in conjunction with the Alpha Pro charge regulator, which controls the alternator's output voltage and current. Together with the Alpha Pro regulator, the Mastervolt Alternator is capable of fast and safe charging of lead-acid and Li-Ion batteries, following the Mastervolt 3-Step charge process.



This manual should be read in combination with the Alpha Pro manual.

4 BEFORE YOU START THE INSTALLATION

4.1 Mounting bracket

Mastervolt has no brackets in its portfolio. You could opt for the following to make the alternator fit on the engine:

1. Order the engine with pre-installed alternator bracket (also known as PTO or Generator option).
2. Consult your dealer/distributor for the availability of an aftermarket 2nd alternator mounting kit.
3. Construct your own bracket. You need a solid mounting bracket which must be resistant to strong vibrations. This is specialist work and should be carried out by qualified personnel only.

4.2 Rotation direction

Alpha Compact alternator: When selecting the installation location, you must consider the rotation direction. For the internal fans to work properly, the rotation direction should be clockwise, viewed from the pulley side of the Alpha Compact.

Alpha alternator: The Alpha alternator is equipped with a bidirectional fan. Therefore, it may rotate in either a clockwise or counterclockwise direction.

4.3 Isolating bushings (Alpha Compact only)

Alpha Compact alternators are non-isolated, meaning the negative output is connected to the metal enclosure. Engine manufacturers may stipulate isolated mounting of the alternator, e.g. to protect sensitive engine electronics. Mastervolt can provide optional isolating bushings suitable for this purpose. For each mounting hole of the alternator, order one set of isolating bushings. See also Figure 4 on page 11, and Figure 11 on page 15.

Notes: - The mounting hole diameters may vary in size, even within a single model. Make sure to order the correct bushing.
- Using the bushings reduces the diameter of the hole! From M10 to M8 and from M12 to M10.

Product code Isolating Kit	Suitable for Alpha Compact model:
48420242	Alpha Compact 28/150 & 28/110
48420241	Alpha Compact Mercedes-Benz 14/120 & 14/200 Note: with insulation sockets not suited for alternator holder N62!
48420240	Alpha Compact Volvo Penta

4.4 Drive belt

Mastervolt Alternators can be combined with multigroove pulleys and corresponding multirib belt (also known as multibelt or serpentine belt) with profile "PK"; further referred to as "drive belt" or "belt" for short. The drive belt must be capable of driving the total mechanical load of all power consumers on the belt, including the alternator. Please note that Mastervolt does not supply the drive belt.

4.5 Engine load

Mastervolt Alternators draw a certain amount of power from the engine. The drive belt and pulley add mechanical losses. As a rule of thumb, the total mechanical-to-electrical power conversion efficiency can be assumed as 50%. Check if the engine has enough power reserve to produce the additional power drawn at nominal alternator rpm. Refer to section 10.2 on page 21 for the Power Take-Off values.

4.6 Pulleys

Depending on the order, the Mastervolt Alternator is delivered without a pulley, with a double V-belt pulley, or with a multi-groove pulley.

The Alpha 12/130, 24/75, 24/110, and 24/150 Evo, are fitted with a double V-belt pulley as standard but can be ordered with a multigroove pulley.

The Alpha Compact 14/200 and Alpha Compact VP models are fitted with a multi-groove pulley as standard. Other Alpha Compact models come without pulley. Mastervolt provides 6-rib and 8-rib pulleys in various diameters and with or without clutch (also called "overrunning" or "freewheeling" pulleys). The pulley must match the alternator. For available models, see section 10.4 on page 26.

4.6.1 Pulley type selection

The standard pulley is recommended for most situations. In case of a long drive belt and/or if many power consumers are attached to the belt, the use of a clutch pulley is recommended. This will minimize wear and tear of the belt and belt tensioner.

4.6.2 Pulley size selection

To choose the correct size of the alternator pulley, you must consider many variables:

- engine size (kW);
- engine idle speed;
- engine cut-off point (= max. rpm);
- alternator maximum rpm;
- diameter of the crank shaft pulley which will be used to drive the alternator.

General rules:

1. At the engine idle speed (A), the alternator idle speed (B) should be 1800rpm or higher.
2. $B / A =$ minimum pulley ratio.
3. At the engine max speed (D), the alternator speed should be below the maximum alternator speed (E).
4. $E / D =$ maximum pulley ratio.
5. Choose a pulley ratio within these extremes.

Example: Assumptions: Engine idle speed = 800rpm, Engine cut-off point = 5000rpm, crank shaft pulley diameter = 160 mm.
Alternator: Alpha Compact 28/110 (refer to section 10.2 for specifications):

Engine idle speed	A	800	rpm
Alternator idle speed	B	1800	rpm
Minimum pulley ratio (= B / A)	C	2.25	x
Engine max speed	D	5000	rpm
Alternator maximum speed	E	15000	rpm
Maximum pulley ratio (= E / D)	F	3.0	x
Crank shaft pulley diameter	G	160	mm
Max. alternator pulley diam. (= G / C)	H	71.1	mm
Min. alternator pulley diam. (= G / F)	I	53.3	mm
Selected pulley diameter	J	55	mm
Actual Pulley ratio (= G / J)	K	2.9	x

It follows that the pulley diameter must be in the range of 53.3mm to 71.1mm. Selecting a relatively small diameter has the advantage of high output power at idle and full power reached at low rpm. Selecting a small pulley also means the alternator represents a higher mechanical load to the engine at idle speed. For a powerful engine, you may select a 55mm pulley. For a smaller engine, a larger diameter such as 66mm may be optimal.

4.6.3 Calculating alternator output

Once the pulley size is known, you can use the output curves given in section 10.4 to look up the charge current at idle speed. Multiplying the engine idle speed with the pulley ratio will give you the alternator speed at idle: $800 \times 2.9 = 2327$ rpm. From the performance curve of the Alpha Compact 28/110, we read approximately 60A of output.

To calculate the engine speed where the alternator reaches full output, simply divide the nominal alternator speed by the pulley ratio. In this example, the alternator will reach its full capacity at engine speed: $6000 / 2.9 = 2060$ rpm.

Note: No rights can be derived from this example!

4.6.4 Pulley alignment

For different pulleys, the distance between the inside of the mounting foot to the first rib of the drive belt can be different. Choose an optimal distance as to minimize the pulley offset.

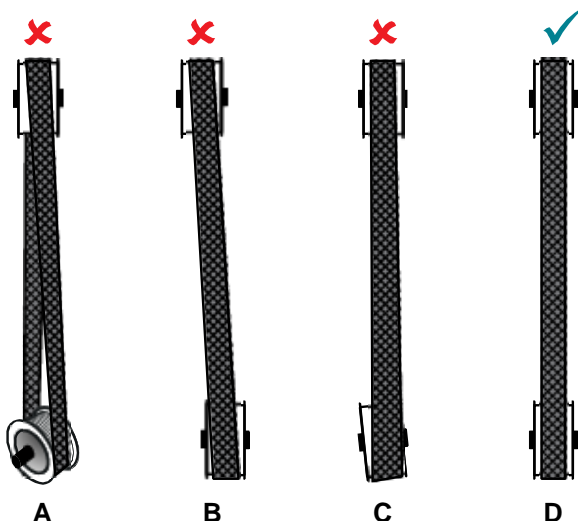

Note: Depending on the mounting method, alternative adjustments to the offset may be possible such as adding spacers between the bracket and the alternator mounting foot

- A. axial twist
- B. offset
- C. angular differential
- D. correct alignment

Figure 3: Pulley alignment errors

4.7 Pulley installation (Alpha Compact only)

Special tools are needed to mount a pulley. These tools are not delivered by Mastervolt. The following tools are manufactured by MAN Trucks and can be obtained from a local vendor or ordered online.



CAUTION!

Damage as a result of the use of incorrect tools may result in loss of warranty.

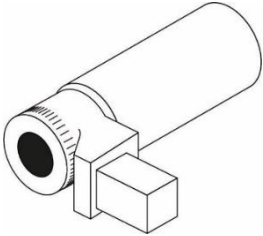

ADJUSTING WRENCH SW22 (Y1)

To remove/install multigroove pulley, in combination with handle (Y2) and TORX screwdriver insert (X2) and torque wrench (X3).

[22mm deep socket with external drive; e.g. MAN 80.99603-6029]

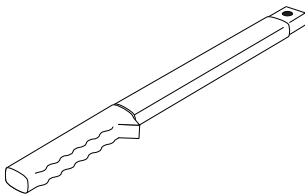

HANDLE 14X18X630 (Y2)

To remove/install standard multigroove pulley, in combination with adjusting wrench (Y1)

[MAN 08.06460-0002]

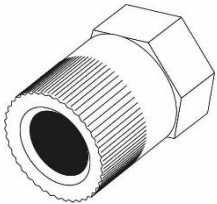

Adapter (X1)

To remove/install clutch pulley, in combination with TORX screwdriver insert (X2) and torque wrench (X3).

[Clutch pulley removal tool, spline 33 teeth, outer diameter 19,6mm, 22HEX drive; e.g. MAN 80.99603-0423]

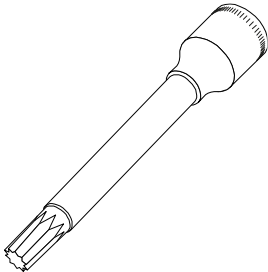

TORX SCREWDRIVER INSERT (X2)

To remove/install standard or clutch pulley, in combination with adapter (X1) and torque wrench (X3).

[XZN M10 x 102mm/140mm, 1/2"; e.g. MAN 80.99603-0318 or Stahlwille 03261410]

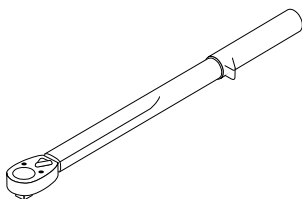

TORQUE WRENCH 20-100Nm (X3)

To remove/install standard or clutch pulley, in combination with adapter (X1) or (Y1) and TORX screwdriver insert (X2).

[Torque wrench 20-100Nm 1/2"; e.g. MAN 08.06450-0002]

4.7.1 Standard pulley

1. Slide the multigroove pulley (B1) onto the alternator shaft (C1).
2. Thinly apply retaining compound (LOCTITE® 648) on the thread and contact surface of the new lock nut (A1).
3. Mount the new lock nut.
4. Fit the adjusting wrench (Y1) with handle (Y2) on the lock nut of the multigroove pulley.
5. Place the torque wrench (X3) and torx insert (X2) in the alternator shaft.
6. Hold the torque wrench (X3) and handle (Y2) and tighten the lock nut (anti-clockwise) to a **torque of 80 Nm**.

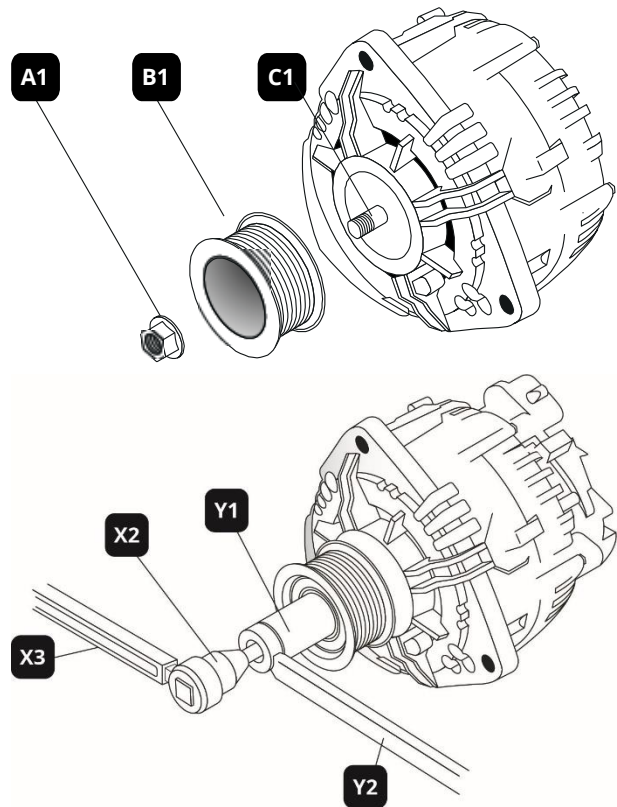

4.7.2 Clutch pulley

1. Thinly apply threadlocking compound (LOCTITE® 270) on the alternator shaft (A2).
2. Place the adapter (X1) on the clutch pulley (B2) and slide onto the alternator shaft (A2).
3. Insert the torx insert (X2) into clutch pulley (B2).
4. Hold the adapter (X1) and use the torque wrench (X3) and torx insert (X2) to tighten the clutch pulley (B2) to a **torque of 85 Nm**.

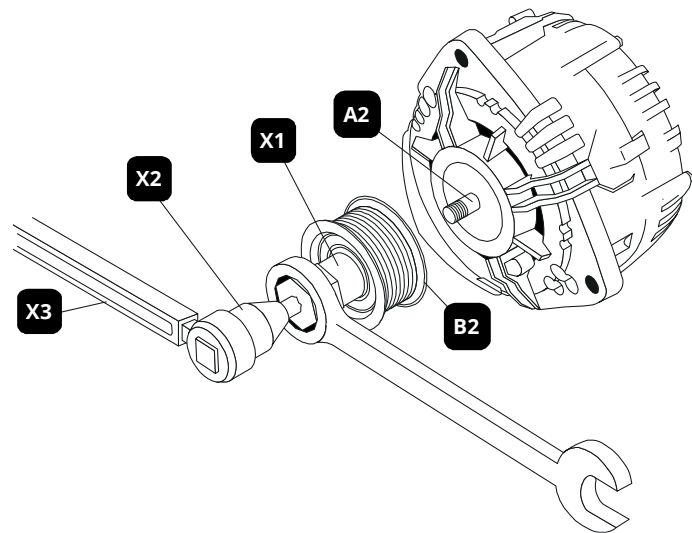

5. Remove the special tools.
6. Add a protection cover (C2).

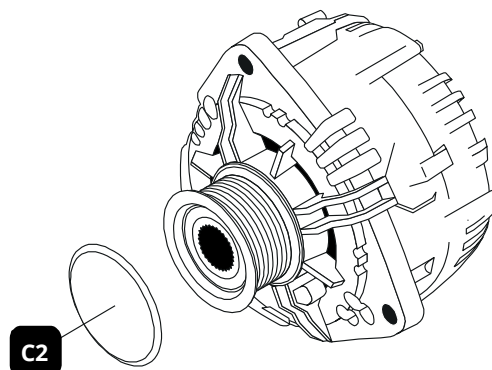

5 MECHANICAL INSTALLATION

During installation and commissioning of the Mastervolt Alternator, the Safety Instructions are applicable at all times. See chapter 2 of this manual.

5.1 Preparations

Turn off all switches and electrical loads. Disconnect the battery. It is advised to make pictures of the current situation, showing how the belt is routed around the pulleys.

5.2 Prepare mounting location

5.2.1 Main alternator upgrade

1. Remove the drive belt. Loosen the alternator bolts and tilt it forward to create slack in the belt. If there is an auto-tensioner pulley, use a socket wrench to loosen it. Now you can remove the belt from the pulleys.
2. Remove the old alternator.
3. Clean and check the condition of mechanical parts and mounting points. Carefully check the belt and tensioner (if applicable) for signs of wear. Replace both if necessary.

5.2.2 Secondary alternator installation

Remove the main drive belt according to section 5.2.1. Attach the mounting bracket to the engine. Install other parts of the alternator mounting kit, such as idler pulleys, double pulleys, belt tension adjuster according to the instructions of the manufacturer.

5.3 Alternator mounting

Saddle mount: (Figure 5)	Foot mount: (See Figure 6)	Pad mount: (Figure 7 & Figure 8)
Alpha 12/130	Alpha Compact 28/110	Alpha Compact 14/200
Alpha 24/75	Alpha Compact 28/150	
Alpha 24/110	Alpha Compact 14/120 Mercedes-Benz	
Alpha 24/150 Evo	Alpha Compact 14/200 Mercedes-Benz	
Alpha Compact 14/140 Volvo Penta	Alpha Compact 28/200 Mercedes-Benz	
Alpha Compact 28/80 Volvo Penta		
Alpha Compact 28/110 Volvo Penta		
Alpha Compact 28/150 Volvo Penta		

• Isolated Mounting

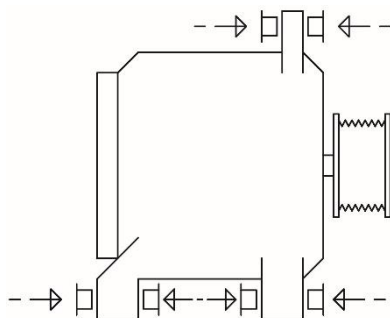

If isolated mounting is required, insert isolating bushings (Alpha Compact only) on either side of each mounting hole. Slide the cable lug of the ground cable (discussed in section 6.3) between one of the isolating bushing and the alternator. Cut the bushings to size. Example: for an alternator model with 3 mounting positions, insert 6 bushings.

Figure 4: Inserting isolation bushings

- **Saddle Mount**

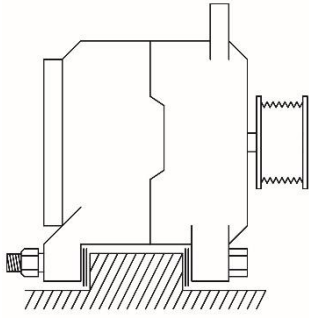

Figure 5: Alternator mounting – saddle mount

Position the alternator mounting ears over the mounting foot and slide in the alternator mounting bolt. Check for backlash. Align the pulley with the crank shaft pulley and fill any empty space on either side of the mounting foot with shims. Loosely attach the alternator, adding a spring washer and locking nut to the other end of the bolt.

Saddle mount is also known as dual foot mount.

- **Foot Mount**

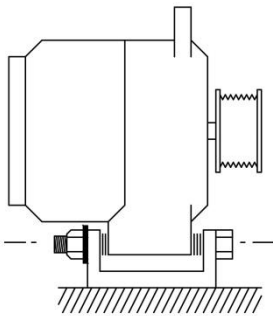

Figure 6: Alternator mounting – foot mount

Position the alternator mounting foot between the two ears of the mounting bracket and slide in the alternator mounting bolt. Check for backlash. Align the pulley with the crank shaft pulley and fill up any empty space on either side of the mounting foot with shims. Loosely attach the alternator, adding a spring washer and locking nut to the other end of the bolt.

- **Pad Mount**

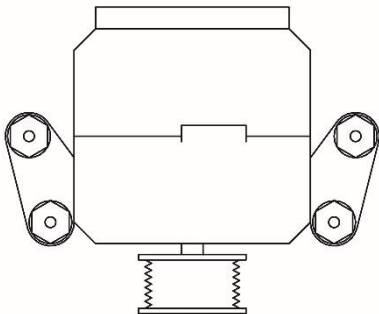

Figure 7: Alternator mounting – pad mount, front view

Slide the alternator into the correct position. Apply a thin layer of threadlocking compound (LOCTITE® 270) on the alternator mounting bolts and tighten the bolts.

Pad mount is also known as direct mount.

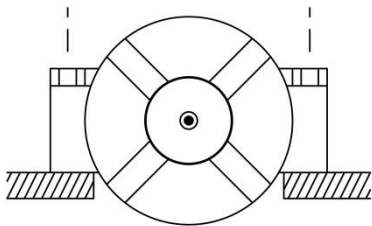

Figure 8: Alternator mounting – pad mount, top view

5.4 Drive belt re-installation

5.4.1 With auto-tensioner pulley

1. Run the drive belt through the pulleys, skipping the auto-tensioner (item 1 in Figure 9).
2. Loosen the auto-tensioner using a wrench (item 2 in Figure 9).
3. With the belt around all the other pulleys, slide it over the auto-tensioner (item 1 in Figure 9) while still holding pressure on the wrench.
4. Once the belt is in place, slowly reduce the pressure on the wrench, allowing the tensioner pulley to tighten the belt.

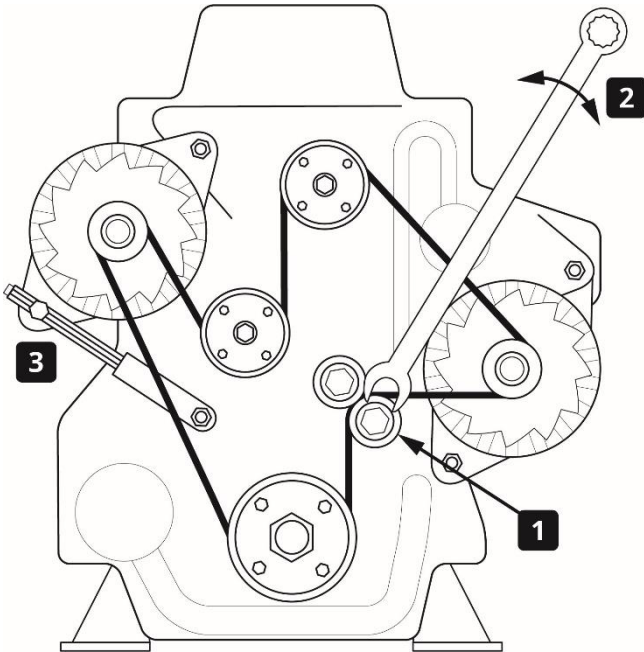

Figure 9: Re-installation with auto-tensioner

5.4.2 No auto-tensioner pulley

1. Run the drive belt through the pulleys, skipping the alternator.
2. Tip the alternator forward and loosely fix the adjustment ear to the adjustment arm (item 3 in Figure 9).
3. Now slide the belt over the alternator pulley.
4. Tighten the belt by pulling the alternator backward, applying force to the front of the alternator housing only.
5. Set the belt tension per manufacturer's recommendations. Use a belt tension gauge to verify the tension.

5.4.3 Final check

Double check the belt alignment. Firmly tighten all alternator mounting bolts.

6 ELECTRICAL INSTALLATION



WARNING

Installation work should be carried out by qualified personnel only.



CAUTION!

Short circuiting or reversing polarity may lead to serious damage to the batteries, the alternator, the Alpha Pro regulator, the cabling and/or the terminal connections. Fuses cannot prevent damage caused by reversed polarity. Damage caused by reverse polarity is not covered by the warranty.

Interrupting current from a running alternator may lead to a significant voltage surge, with damage to the alternator and/or connected equipment and loss of warranty as a result. Carefully follow the instructions in this chapter regarding wiring, fuse size and fuse position.



CAUTION!

Too-thin cables and/or loose connections can cause dangerous overheating of the cables and/or terminals. Tighten all connections well, in order to limit transition resistance as far as possible. Use cables of the correct size. Refer to technical specifications (section 10.2) for recommended wire sizes.

6.1 Precautions

Make sure that everything is switched off:

- remove the engine ignition key;
- disconnect all batteries or remove the DC fuse(s);
- make sure that third parties cannot reverse the measures taken.

6.2 Fuse

The alternator is connected to the battery via an alternator fuse, located as close as possible to the battery. Refer to section 10.2 on page 21, for more information.

6.3 Wiring

For Alpha Compact models refer to Figure 10 on page 15. For other Alpha models refer to Figure 12 on page 16.

Notes:

- In case of an Alpha Compact alternator: whether the alternator is mounted in an isolated or a non-isolated way, it is **OBLIGATORY** to route a ground conductor from one of the alternator mounting points to electrical ground. If isolating bushings are not used, one of the mounting bolts can be used for this purpose. If isolating bushings are used, refer to Figure 11 on page 15.
- The current rating of the positive and negative alternator wiring must be higher than the fuse size.
- Use the supplied cable assembly for connection of the Alpha Pro regulator.
- For detailed information on how to connect a tachometer, indication lamp, oil pressure switch or battery isolator, refer to the Alpha Pro manual.
- For Alpha Compact models, the alternator temperature sensor must be connected to the temperature input of the Alpha Pro charge regulator. In case lead acid batteries are used, it is advised to install a MasterShunt with battery temperature sensor and make a MasterBus connection to the Alpha Pro to use automatic temperature compensation.



CAUTION!

Point 7 in Figure 10 and in Figure 12 should **NOT** be connected to engine ignition. Refer to the Alpha Pro manual, which explains how to obtain a proper “engine run” signal. **Failure to do so may lead to overcharging of the batteries and / or overheating of the alternator field winding, which is not covered by warranty.**

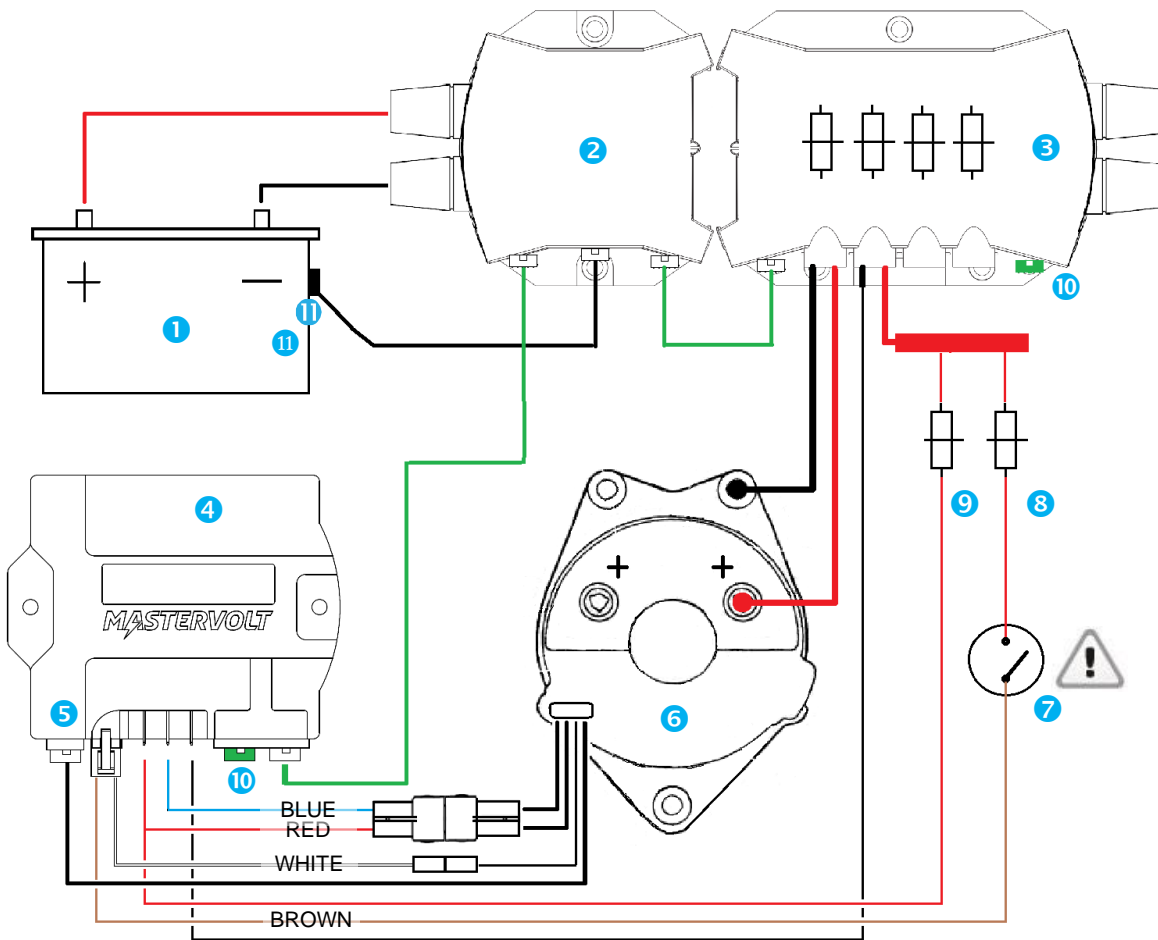

- | | |
|--|---|
| 1 Lead acid battery with battery temperature sensor (11) | 6 Alpha Compact alternator |
| 2 MasterShunt | 7 Engine Run Contact (reg on) - refer to Alpha Pro manual |
| 3 DC distribution with dedicated alternator fuse | 8 Fuse - refer to Alpha Pro manual |
| 4 Alpha Pro charge regulator | 9 Fuse (included in Alpha Pro wiring loom) |
| 5 Alternator temperature sensor | 10 MasterBus Terminator |

Figure 10: Wiring diagram Alpha Compact models, with lead acid battery

If isolating bushings are used (Alpha Compact only), mount the ground conductor between the bushing and a mounting point.

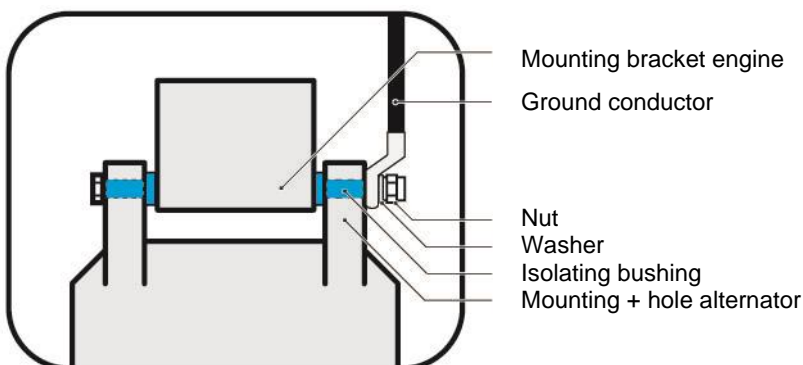
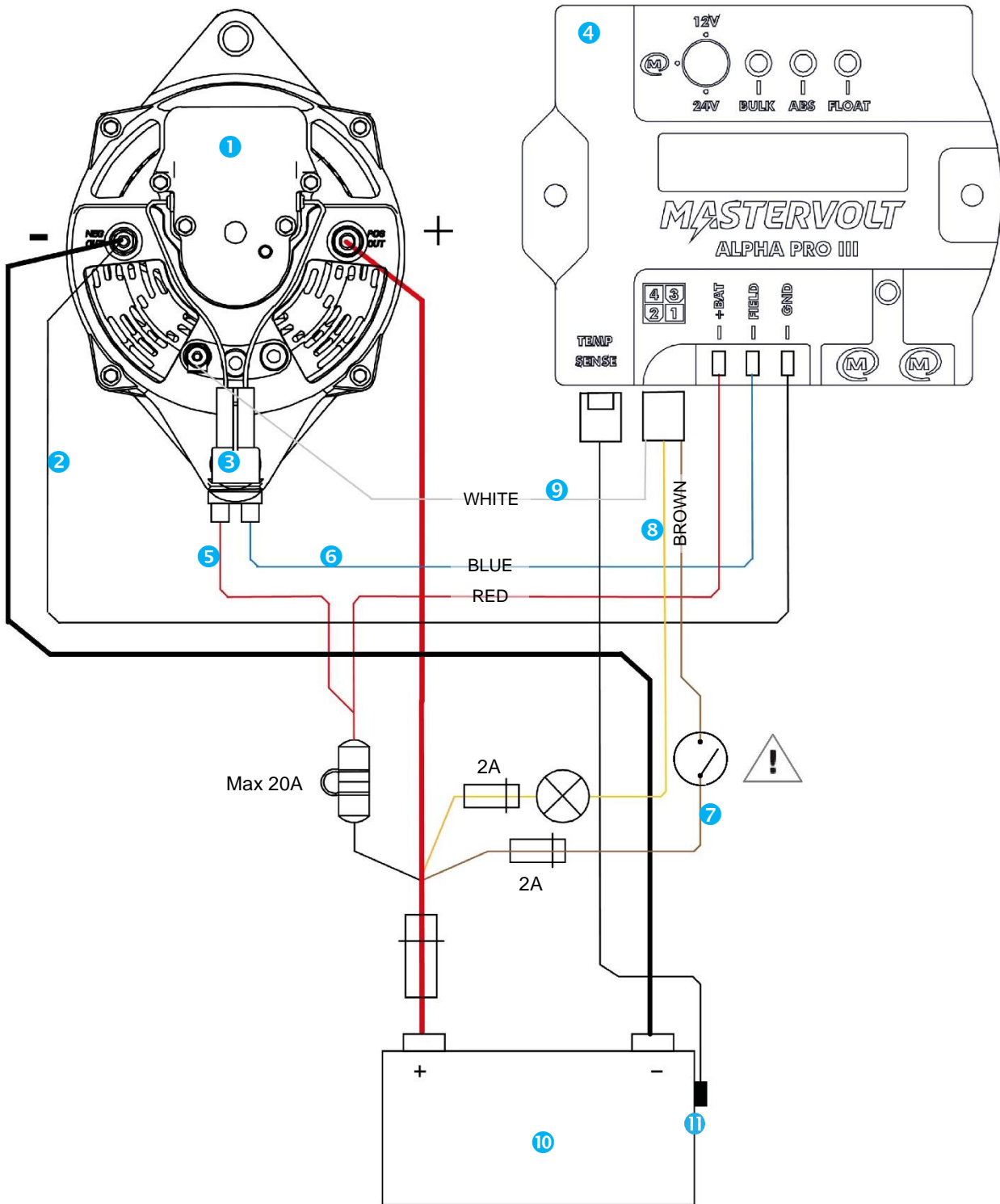

Figure 11: Detailed view of the connection



- 1 Alpha alternator
- 2 Black (GND) wire
- 3 Field connector
(model 24/150 Evo is connected in a similar way but requires the specialty adapter that is included in the delivery)
- 4 Alpha Pro charge regulator
- 5 Red (+ field) wire
- 6 Blue (- field) wire
- 7 Engine Run Contact (reg on) - refer to Alpha Pro manual
- 8 Yellow (D+ lamp) wire
- 9 White (RPM) wire
- 10 Lead acid battery with temperature sensor (11)

Figure 12: Wiring diagram other Alpha models, with lead acid battery

7 COMMISSIONING

7.1 Preparations

1. Wear safety glasses and remove loose fitting clothing and jewelry.
2. Clear the area around moving parts. Remove loose wires and tools.
3. Double check all electrical connections.
4. Reconnect the battery.
5. Switch on the DC power.

7.2 Regulator configuration with MasterAdjust

The installer must be familiar with the configuration tool MasterAdjust. Refer to the Alpha Pro manual for details. The Alpha Pro will be disabled until it is configured and locked via MasterAdjust.

On the MasterAdjust configuration tab:

1. For Alpha Compact models only: go to the **System** section and set the **Temp. sensor** to **Alternator**.
 - a) Set **Start reducing @** to **85 °C**.
 - b) Set **Stop charging @** to **120 °C**.
2. Double check the settings and keep a record of them in this manual.

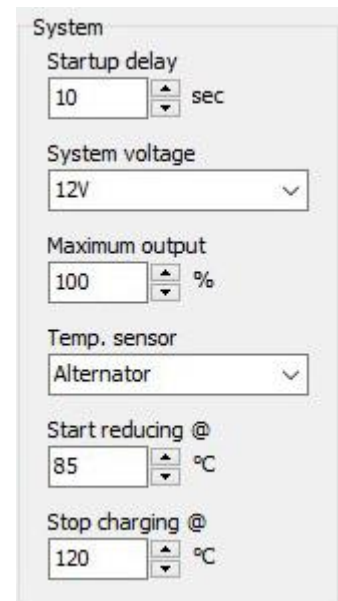

7.3 First operation and testing



WARNING

When the engine is running, be aware of moving parts like V-belts.

1. Measure and record the battery voltage before starting the engine.
2. Bridge the engine run contact by connecting a jump wire, see fig. 13.
The three LEDs on the Alpha Pro should blink to indicate startup mode.
The Bulk LED will go on.
3. Check whether the alternator field coil is energized, by touching the shaft of the alternator with a screwdriver. You should notice a strong magnetic pull. Or measure the field current.
4. Remove the jump wire. The three LEDs on the Alpha Pro will go out.
5. Start the engine. Check for abnormal noise or vibration.
After 10 seconds, the yellow (bulk) LED will illuminate, indicating that the charge cycle begins.
6. Measure and record the battery voltage. It should be higher than measured in step 2, indicating that the alternator is charging.
7. Run the engine at cruising speed for 15 minutes, switching on loads to apply maximum load to the alternator.
8. Stop the engine and check the belt tension. Adjust if necessary.

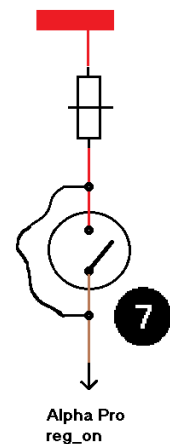

Figure 13: jump wire

7.4 Normal operation

If installed correctly, the Mastervolt alternator and the Alpha Pro regulator will switch on and off automatically when the engine starts and stops. There is no need for adjustment or operation.

8 MAINTENANCE

Alternator maintenance can be part of the overall maintenance of the engine. Alternator parts are subject to wear. To ensure reliable functionality, inspection and maintenance have to be carried out at regular intervals. At least every 500 service hours, the bearings, brushes, and belt(-tension) are to be checked, and replaced if necessary, by a competent specialist. For better cooling it helps to keep the alternator clean.

8.1 Mounting points

Check the mounting of the alternator after the first 50 running hours. Then every 150 running hours or at least every year, whichever comes first. Make sure that the alternator is securely mounted to its applicable brackets. The brackets, in turn, need to be bolted securely to the engine. Poor or loose mountings may lead to damaging vibration as well as reduced belt drive performance.

8.2 Cleaning



CAUTION!

Use only non-aggressive detergents.

The cleaning interval of the alternator strongly depends on environmental conditions but should be maximum six months. Prevent build-up of dirt, grease or dust. If you notice significant build-up of black dust on your alternator and surrounding engine area, check belt tension.

Air flow passages must also be clear so that air can easily pass through the unit. The alternator's bearings are greased for life and cannot be degreased.

8.3 Check tension and condition of the drive belt

An under-tensioned belt will slip on the pulley, fail to turn the alternator's rotor and as a result of the friction, overheat the alternator. An over-tensioned belt causes reduced belt life. The tension of new belts must be checked after the first 50 running hours; then every 150 running hours or at least every year.

Before adjusting the belt tension, inspect it for glazing, cracks, or dryness. A worn or damaged belt should be replaced, including the tensioner (if applicable). If the belt is in satisfactory condition, check the belt tension with cricket belt tension gauge. Refer to the manufacturer's specifications for proper belt tension.

If you replace a worn or damaged drive belt, the new belt should be checked for proper tension as well. A new drive belt loses up to 60% of its tension during the first few hours of operation. If a new belt has been installed, run the engine with full load connected to the alternator for approximately 15 minutes. Then check the belt tension again and adjust it if necessary.

9 TROUBLESHOOTING

9.1 Trouble shooting hints

- Check if 12-14V is present at alternator output
- Check if 12-14V is available at field current input. When field current is present, hold a Ferro-metallic object near the shaft of the alternator. The field coil functions correctly if a strong magnetic pull is observed.

9.2 Fault finding table

Problem	Possible cause	Action
Battery loses charge or Insufficient charge output	Defective battery.	Check battery, replace if necessary.
	Slipping alternator drive belt.	Check belt condition and tension.
	Battery terminals loose or corroded.	Clean, grease and tighten battery terminals.
	Alternator internal fault.	Test and repair if necessary.
	Regulator fault.	Refer to regulator manual.
	Engine run signal contact not working.	Jump wire engine run signal contact. Repair if necessary.
	Bad electric connection in main charging circuit.	Check cables for damage. Check ground wire.
	Short circuit component causing battery drain even when switches are off.	Measure battery output current drain and check system.
Blown alternator fuse.		Verify fuse value. Replace with fuse according to specifications (section 10.2).
	Battery temperature sensor not correctly configured.	Check MasterBus configuration.
Charge current higher or lower than expected	Charge current can be up to 20% higher when cold. Charge current can be up to 15% lower when hot.	No action required.
Charge voltage too high / low	Wrong battery sense voltage.	Check battery voltage sense wiring.
Noise	Belt misalignment.	Make sure the pulleys are aligned.
	Anti-clockwise rotation direction (Alpha Compact only).	Check the rotation direction (Alpha Compact only).
	Belt tension too high.	Check belt tension.
	Pulley mounting.	Fasten pulley, using special tools.
	Worn or misaligned tensioner pulley.	Check tensioner pulley.
Pivot bushing worn down	Belt misalignment.	Make sure the pulleys are aligned.
Alternator is getting hot while engine is NOT running	Rotor field windings are excited while engine is not running. Regulator is still on (BULK/ABS/FLOAT LED is on).	Switch off DC immediately to avoid field winding damage due to overheating. Check engine run contact for correct operation. Check wiring between battery and [reg on] terminal.
Alternator is getting hot while engine IS running	A loose, under-tensioned belt.	Check the tension of the belt.
	Anti-clockwise rotation direction (Alpha Compact only).	Check correct rotation direction (Alpha Compact only).
	Loose plus or minus cable, or ground cable not connected.	Check cables.

10 TECHNICAL DATA

10.1 General specifications

Alpha Compact	14/200	28/110	28/150
Product code	46214200	46228110	46228150
Mounting*	Pad mount	Foot mount	Foot mount
Pulley included	Yes	No	No
Alpha Pro III charge regulator included	#46214200 no #46614200 yes	#46228110 no #46628110 yes	#46228150 no #46628150 yes
Weight	7.5 kg [16.5 lb.]	7.4 kg [16.3 lb.]	7.9 kg [17.4 lb.]
Isolated operation	yes, with optional isolation bushings		
Rotational direction	clockwise (viewed from pulley side)		
Cooling	integrated dual fan		

Alpha Compact	14/140 Volvo Penta	28/80 Volvo Penta	28/110 Volvo Penta	28/150 Volvo Penta
Product code	46214142	46228082	46228112	46228152
Mounting*	Saddle mount	Saddle mount	Saddle mount	Saddle mount
Pulley included	Yes	Yes	Yes	Yes
Weight	6.9 kg [15.2 lb.]	6.9 kg [15.2 lb.]	7.4 kg [16.3 lb.]	7.9 kg [17.4 lb.]
Isolated operation	yes, with optional isolation bushings			
Rotational direction	clockwise (viewed from pulley side)			
Cooling	integrated dual fan			

Alpha Compact	14/120 Mercedes-Benz N62	14/200 Mercedes-Benz N62	28/200 Mercedes-Benz N62
Product code	46214120	46214203	46228203
Mounting*	Foot mount	Foot mount	Foot mount
Pulley included	No	No	No
Weight	6.7 kg [14.8 lb.]	7.5 kg [16.5 lb.]	7.5 kg [16.5 lb.]
Isolated operation	yes, with optional isolation bushings		
Rotational direction	clockwise (viewed from pulley side)		
Cooling	integrated dual fan		

Alpha	12/130	24/75	24/110	24/150 Evo
Product code	48212130	48224075	48224110	48224152
Mounting*	Saddle mount	Saddle mount	Saddle mount	Saddle mount
Pulley included	Yes **	Yes **	Yes **	Yes **
Weight	10.1 kg [22.3 lb.]	10.1 kg [22.3 lb.]	10.1 kg [22.3 lb.]	12 kg [26.5 lb.]
Isolated operation	yes, isolated from ground			
Rotational direction	clockwise or counterclockwise			
Cooling	external bidirectional fan	external bidirectional fan	external bidirectional fan	integrated bidirectional fan

* Refer to section 5.3 on page 11.

** Double V-belt pulley.

10.2 Technical specifications

Alpha Compact model	14/200	28/110	28/150
System voltage	12 V	24 V	24 V
Battery capacity	400 – 2000 Ah	220 – 1100 Ah	300 – 1500 Ah
Nominal current ¹⁾ @ 6000rpm	200 A	110 A	150 A
Recommended DC fuse	250 A	160 A	200 A
Recommended DC wire size (up to 3m / 10ft)	70 mm ² [AWG3 0]	35 mm ² [AWG2]	50 mm ² [AWG0]
Recommended wire size (3 to 5m / 10 to 16ft)	95 mm ² [AWG4 0]	50 mm ² [AWG0]	70 mm ² [AWG2 0]
Cut-in speed	1350 rpm	1400 rpm	1700 rpm
Max. rotational speed	20.000 rpm	15.000 rpm	16.000 rpm
Power Take-Off (kW/hp)	5.6 / 7.6	6.2 / 8.3	8.4 / 11.4
Number of pole pairs	6	6	6
Max. operating temperature ⁴⁾	120 °C [248 °F]		
Connections	positive output stud = 2x M8; W (rpm) signal connection = isolated fast-on; field current connection = Mastervolt plug		
Temperature sensor	integrated, RJ12 connector		
Reduce charging at	85 °C [185 °F]		
Stop charging at	120 °C [248 °F]		

Alpha Compact model	14/140VP	28/80VP	28/110VP	28/150VP
System voltage	12 V	24 V	24 V	24 V
Battery capacity	280 – 1400 Ah	160 – 800 Ah	220 – 1100 Ah	300 – 1500 Ah
Nominal current ¹⁾ @ 6000rpm	140 A	85 A	110 A	150 A
Recommended DC fuse	175 A	125 A	160 A	200 A
Recommended DC wire size (up to 3m / 10ft)	50 mm ² [AWG0]	35 mm ² [AWG2]	35 mm ² [AWG2]	50 mm ² [AWG0]
Recommended wire size (3 to 5m / 10 to 16ft)	70 mm ² [AWG2 0]	50 mm ² [AWG0]	50 mm ² [AWG0]	70 mm ² [AWG2 0]
Cut-in speed	1400 rpm	1400 rpm	1400 rpm	1700 rpm
Max. rotational speed	15.000 rpm	15.000 rpm	15.000 rpm	16.000 rpm
Power Take-Off (kW/hp)	4.8 / 6.4	4.8 / 6.4	6.2 / 8.3	8.4 / 11.4
Number of pole pairs	6	6	6	6
Max. operating temperature ⁴⁾	120 °C [248 °F]			
Connections	positive output stud = 2x M8; W (rpm) signal connection = isolated fast-on; field current connection = Mastervolt plug			
Temperature sensor	integrated, RJ12 connector			
Reduce charging at	85 °C [185 °F]			
Stop charging at	120 °C [248 °F]			

Alpha Compact model	14/120 Mercedes-Benz	14/200 Mercedes-Benz	28/200 Mercedes-Benz
System voltage	12 V	12 V	24 V
Battery capacity	240 – 1200 Ah	400 – 2000 Ah	400 – 2000 Ah
Nominal current ¹⁾ @ 6000rpm	120 A	200 A	200 A
Recommended DC fuse	160 A	250 A	250 A
Recommended DC wire size (up to 3m / 10ft)	50 mm ² [AWG0]	70 mm ² [AWG3 0]	70 mm ² [AWG3 0]
Recommended wire size (3 to 5m / 10 to 16ft)	70 mm ² [AWG2 0]	95 mm ² [AWG4 0]	95 mm ² [AWG4 0]
Cut-in speed	1300 rpm	1350 rpm	1300 rpm
Max. rotational speed	20.000 rpm	20.000 rpm	20.000 rpm
Power Take-Off (kW/hp)	3.4 / 4.5	5.6 / 7.6	3.4 / 4.5
Number of pole pairs	6	6	6
Max. operating temperature ⁴⁾	120 °C [248 °F]		
Connections	positive output stud = 2x M8; W (rpm) signal connection = isolated fast-on; field current connection = Mastervolt plug		
Temperature sensor	integrated, RJ12 connector		
Reduce charging at	85 °C [185 °F]		
Stop charging at	120 °C [248 °F]		

Alpha	12/130	24/75	24/110	24/150 Evo
System voltage	12 V	24 V	24 V	24 V
Battery capacity	400 Ah ³⁾	225 Ah	350 Ah	500 Ah
Nominal current @3500rpm	130 A	75 A	110 A	150 A
Recommended DC fuse	160 A	100 A	160 A	200 A
Recommended DC wire size (up to 3m / 10ft)	50 mm ² [AWG 0]	25 mm ² [AWG 3]	35 mm ² [AWG 2]	50 mm ² [AWG 0]
Recommended wire size (3 to 5m / 10 to 16ft)	70 mm ² [AWG 2 0]	35 mm ² [AWG2]	50 mm ² [AWG 0]	70 mm ² [AWG 2 0]
Cut-in speed	750 rpm	750 rpm	1000 rpm	1300 rpm
Max. rotational speed	8000 rpm	8000 rpm	8000 rpm	10000 rpm
Power Take-Off (kW/hp)	2.1 / 2.8	2.3 / 3.1	3.3 / 4.5	5.4 / 7.3
Number of pole pairs	8	8	8	6
Max. operating temperature ⁴⁾	200 °C [392 °F]			
Connections				
- positive output stud B+	M8	M8	M8	M8
- positive output stud B-	M6	M6	M6	M8
- W (rpm) signal	M5	M5	M5	Faston 6.3 mm male ²⁾
- Field current	Mastervolt plug	Mastervolt plug	Mastervolt plug	Mastervolt plug

1) Nominal charge current is specified at 6000rpm, 25°C / 77 °F ambient temperature and a "warm" alternator. When the alternator is cold, charge currents can be up to 20% higher. At high ambient temperature (80°C / 176 °F), charge currents can be up to 15% lower.

2) if not used, ensure to insulate the faston!

3) Based on Mastervolt gel batteries.

4) Temperature of the alternator housing.

10.3 Mechanical specifications – Alternators

Alpha Compact 14/120 Mercedes-Benz & 14/200 Mercedes-Benz & 28/200 Mercedes-Benz (dimensions in mm [inch])

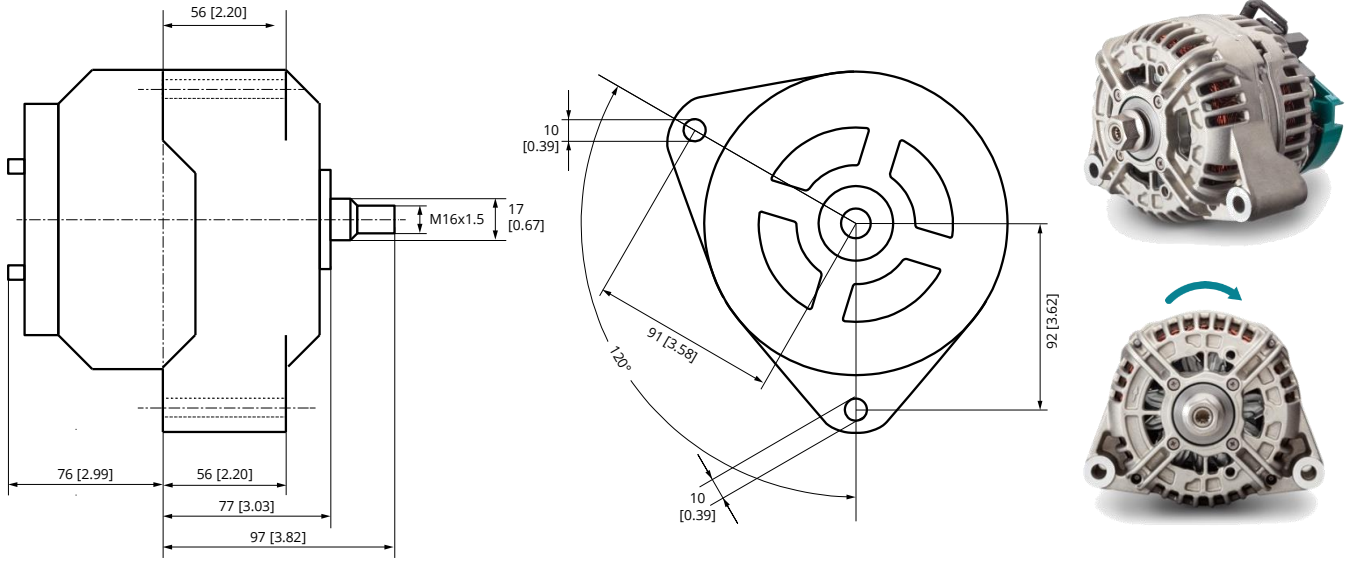

Alpha Compact 14/200 (dimensions in mm [inch])

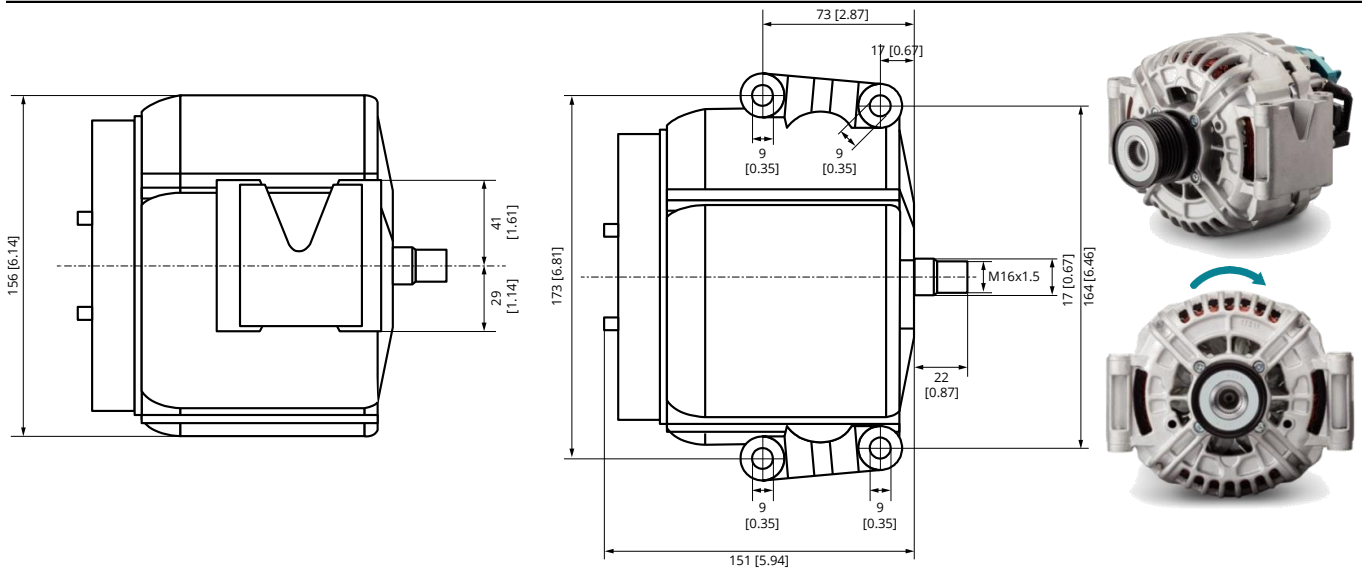

Alpha Compact 28/110 & 28/150 (dimensions in mm [inch])

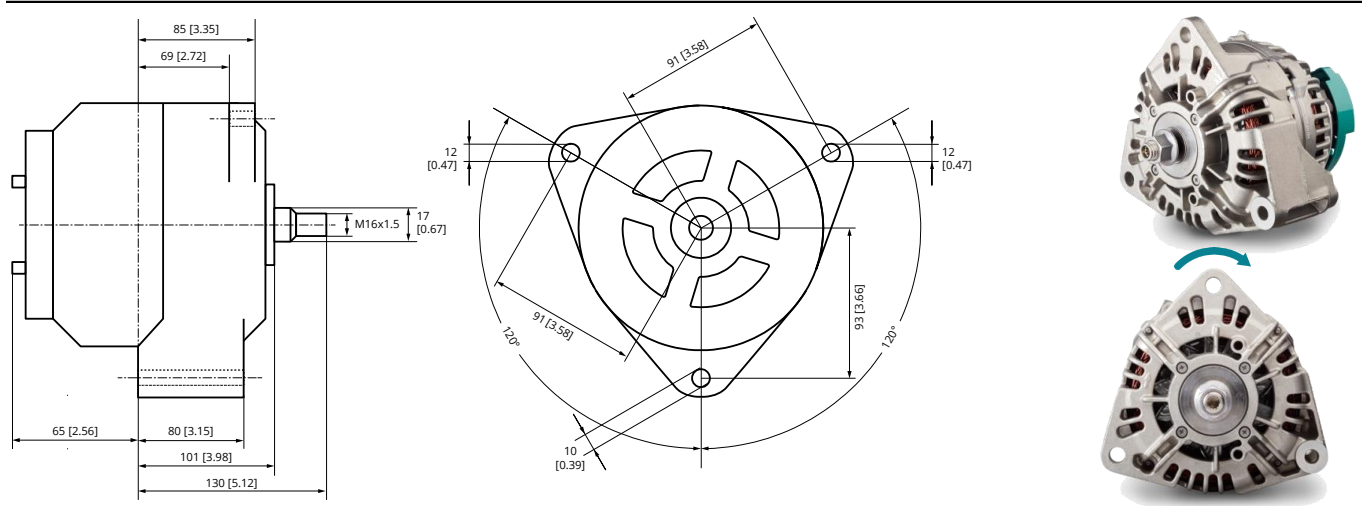

Alpha Compact 14/140 Volvo Penta & 28/80 Volvo Penta & 28/110 Volvo Penta (dimensions in mm [inch])

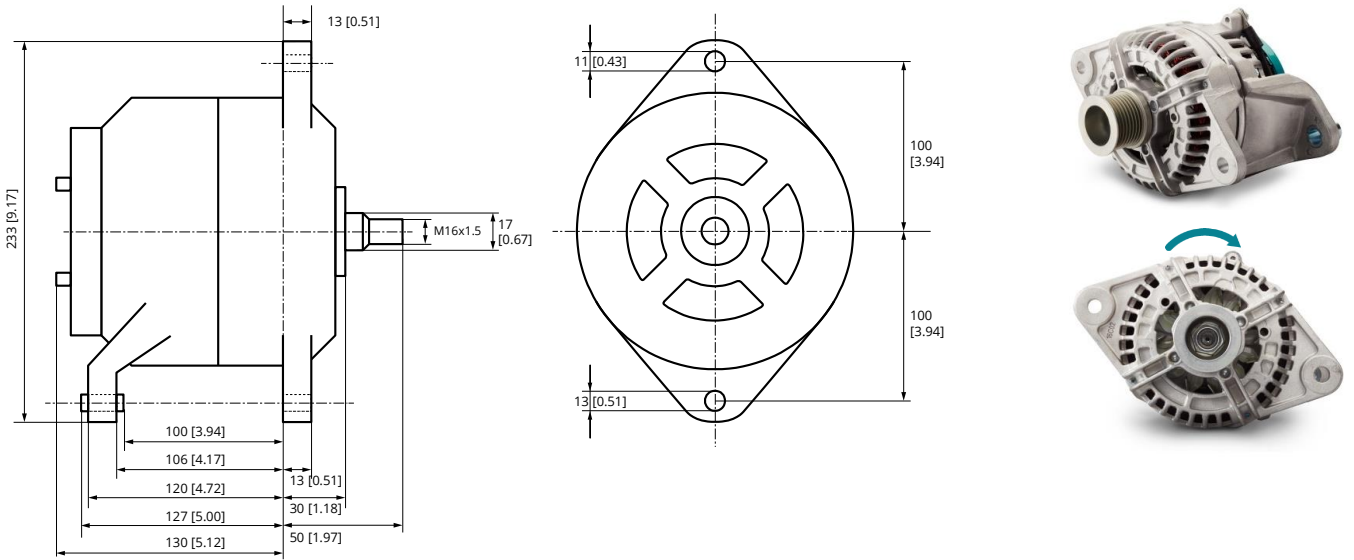

Alpha Compact 28/150 Volvo Penta (dimensions in mm [inch])

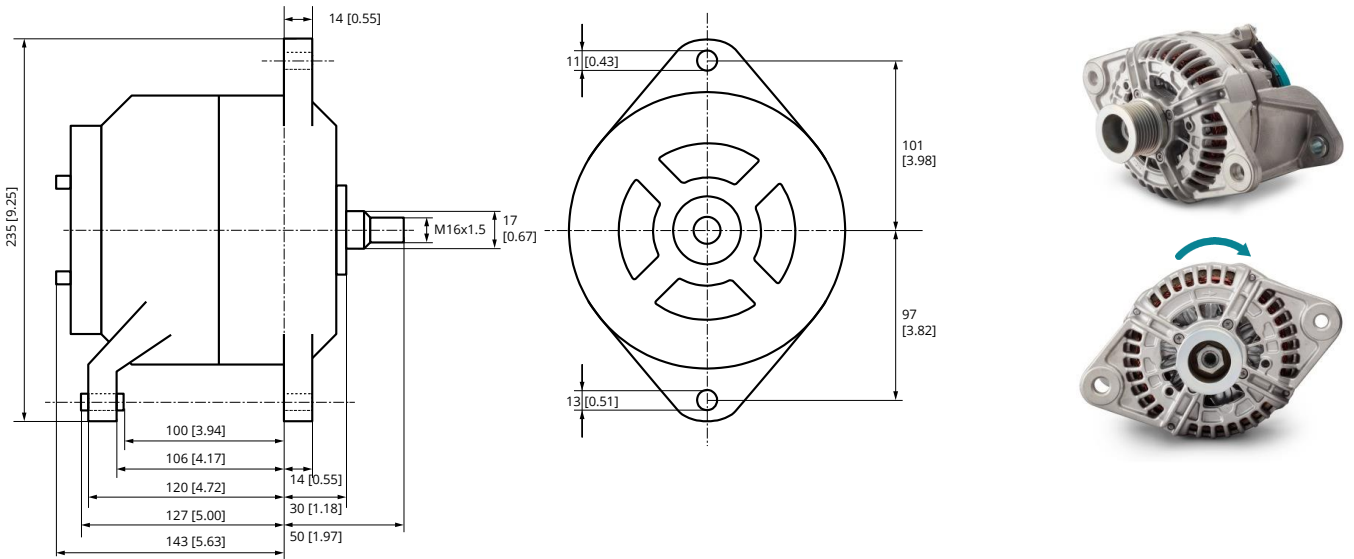

Alpha 12/130 & 24/75 & Alpha 24/110 (dimensions in mm [inch])

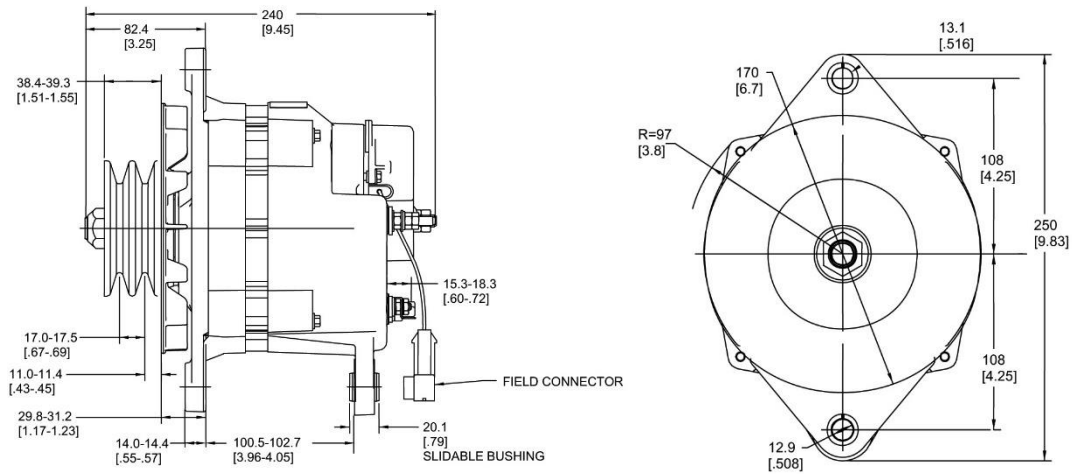

Alpha 24/150 Evo (dimensions in mm)

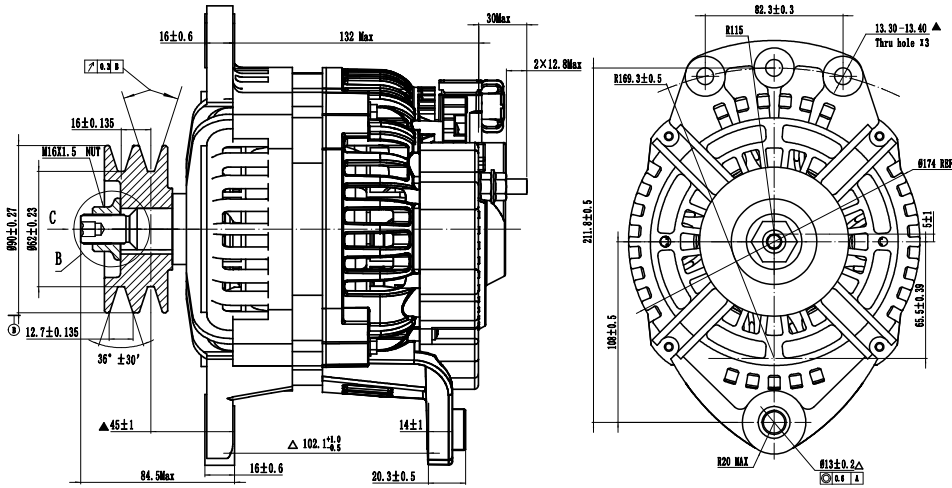

10.4 Mechanical specifications – Pulleys

10.4.1 For Alpha Compact models

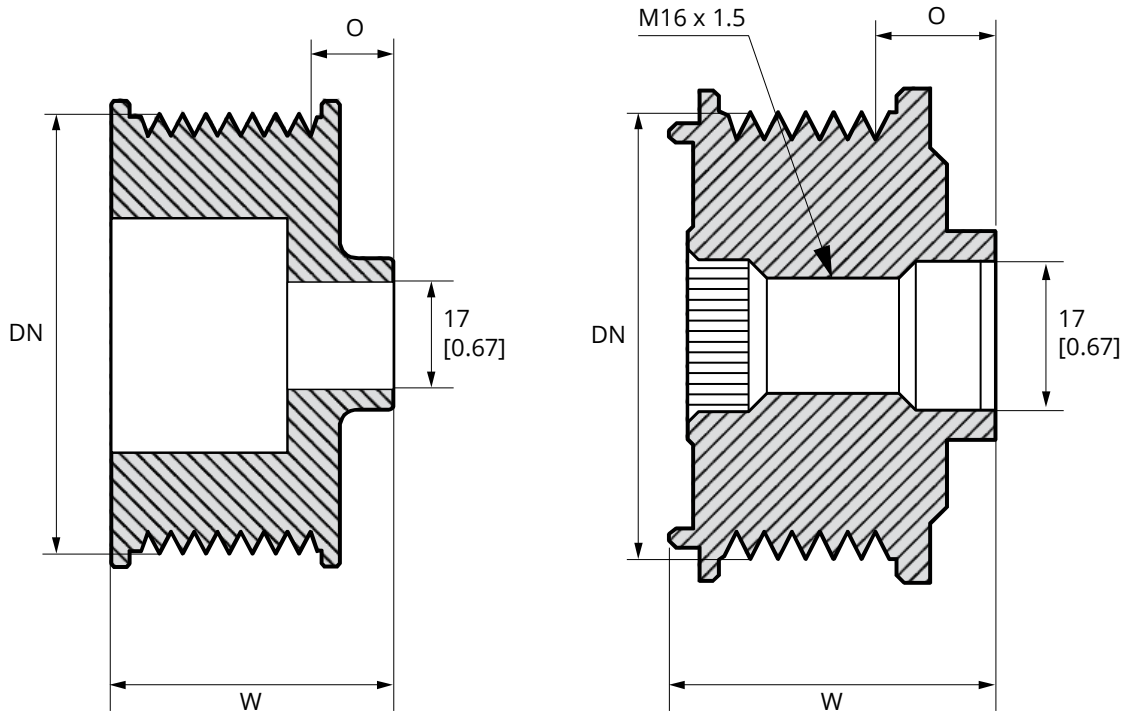

Product code	Type	Grooves	Offset (O)	Width (W)	Diameter (DN)
48420100	Clutch	8	3.9 [0.15]	37.4 [1.47]	57.4 [2.26]
48420110	Clutch	6	15.2 [0.60]	40.3 [1.59]	49.8 [1.96]
48420120	Clutch	6	14.5 [0.57]	42.8 [1.69]	56.2 [2.21]
48420130	Clutch	6	9.9 [0.39]	36.1 [1.42]	55.0 [2.17]
48420140	Clutch	8	4.5 [0.18]	38.9 [1.53]	56.0 [2.20]
48420150	Clutch	8	19.4 [0.76]	49.3 [1.94]	50.0 [1.97]
48420160	Standard	8	5.5 [0.22]	34.6 [1.36]	66.1 [2.60]
48420170	Standard	8	10.0 [0.39]	39.4 [1.55]	48.1 [1.89]
48420180	Standard	2 x 8	5.5 [0.22]	68.7 [2.70]	66.1 [2.60]

Dimensions in mm [inch]

10.4.2 For Alpha models (12/130, 24/75, 24/110, 24/150 Evo)

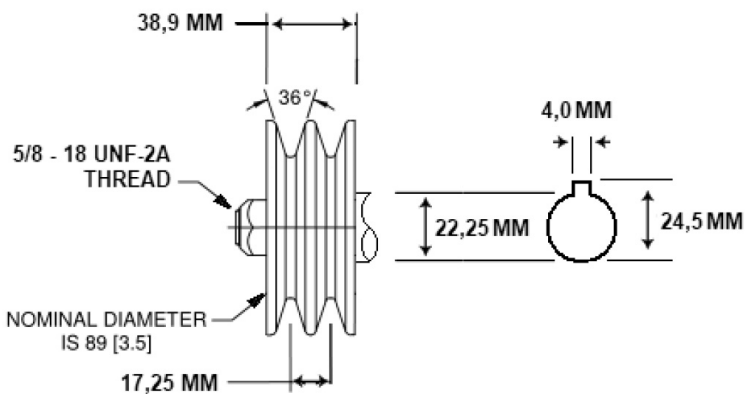

Double V-belt pulley for Alpha 12/130, 24/75, 24/110, dimensions in mm

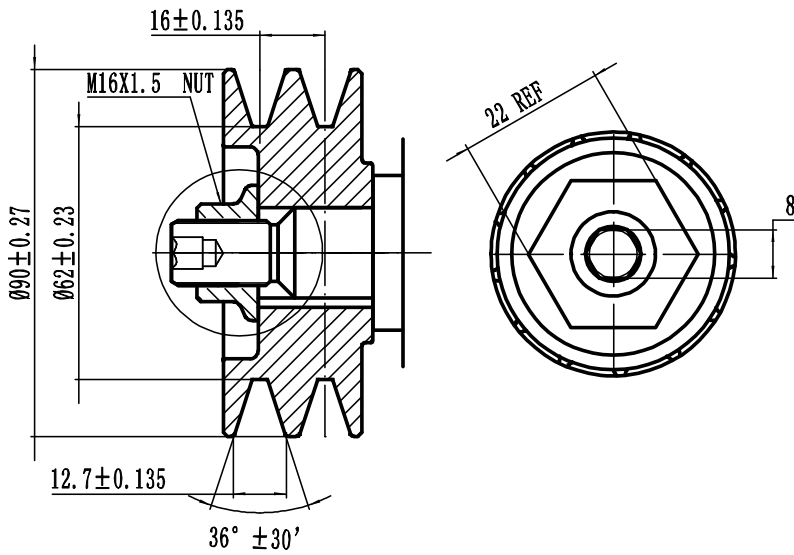

Double V-belt pulley for Alpha 24/150 Evo, dimensions in mm

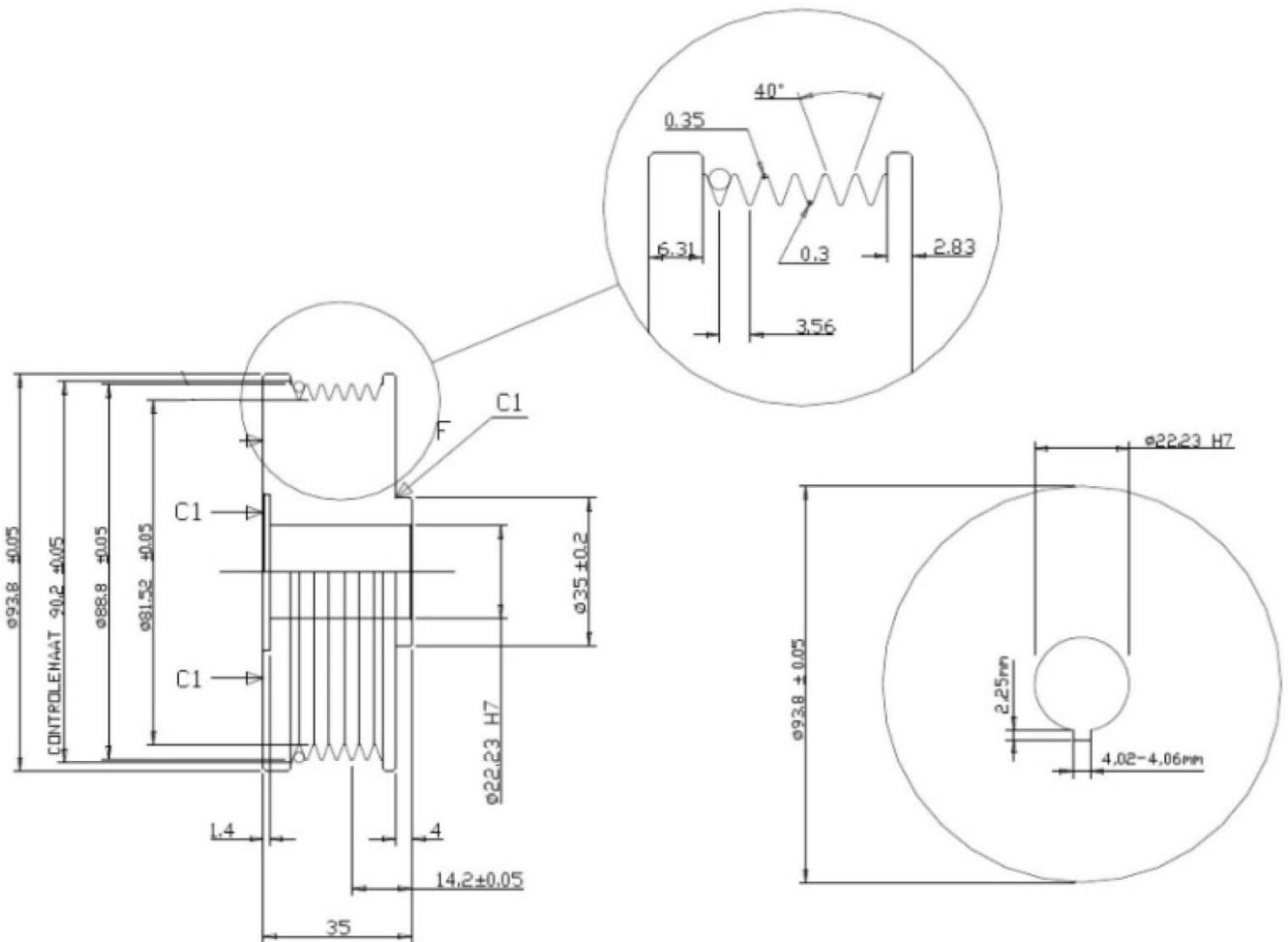

Multigroove pulley dimensions in mm (product code 48400030)

10.5 Output curves

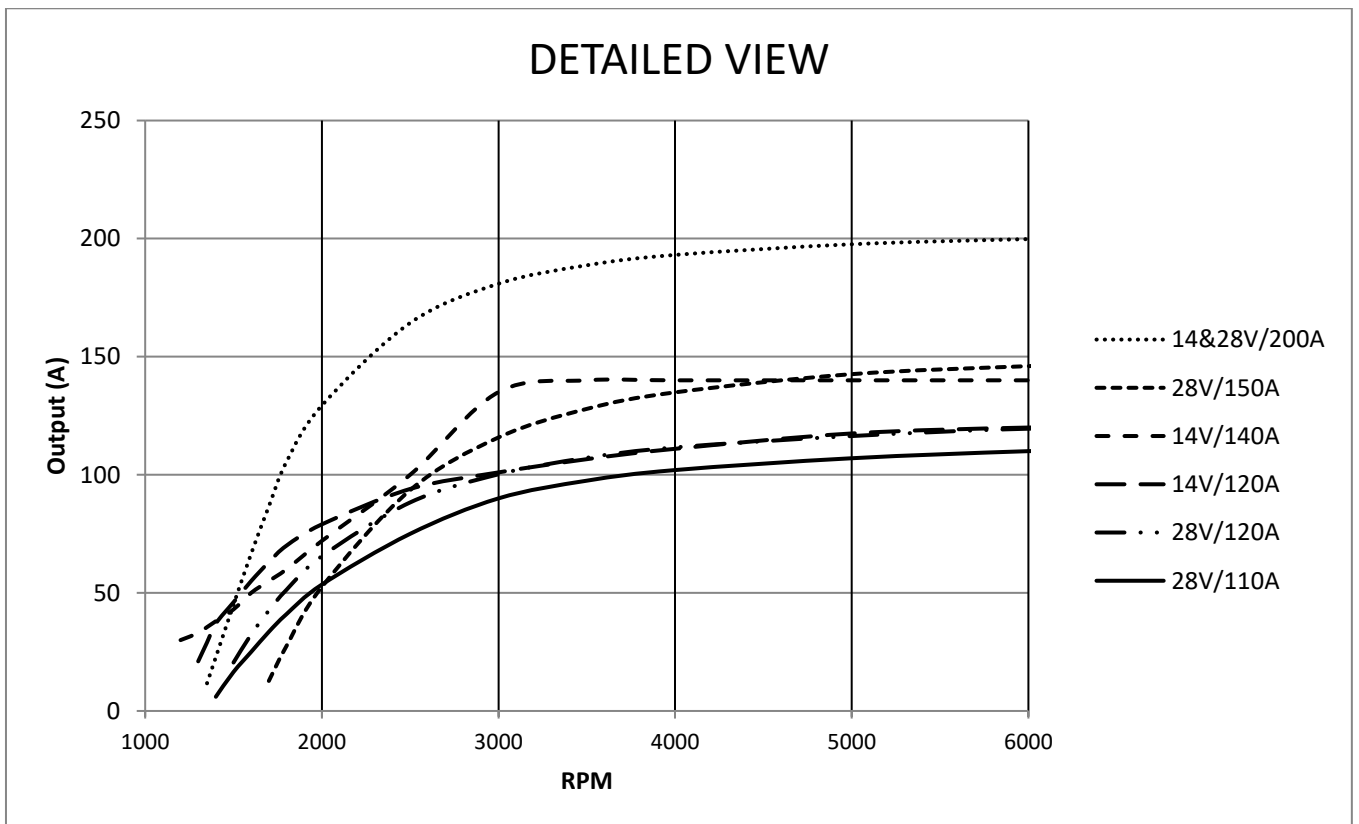
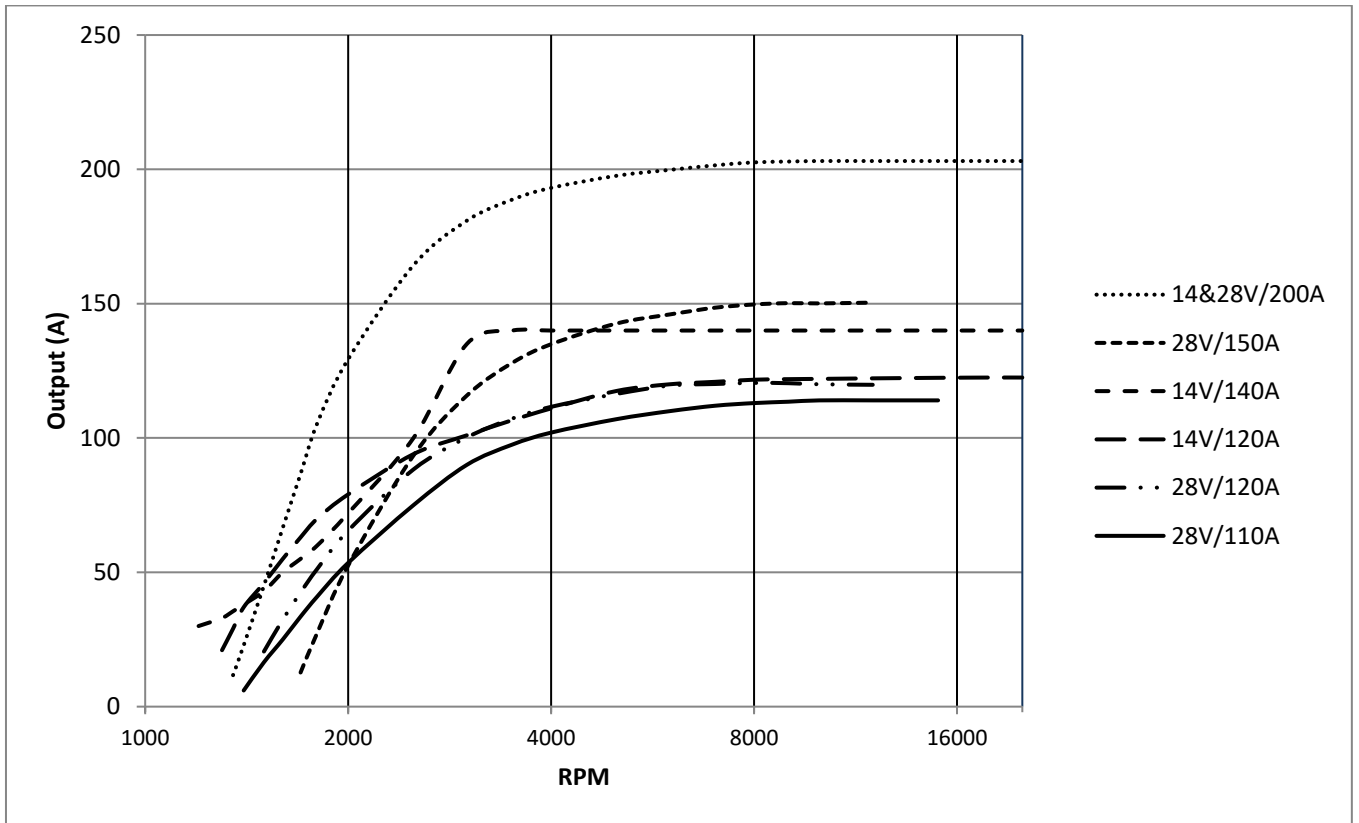

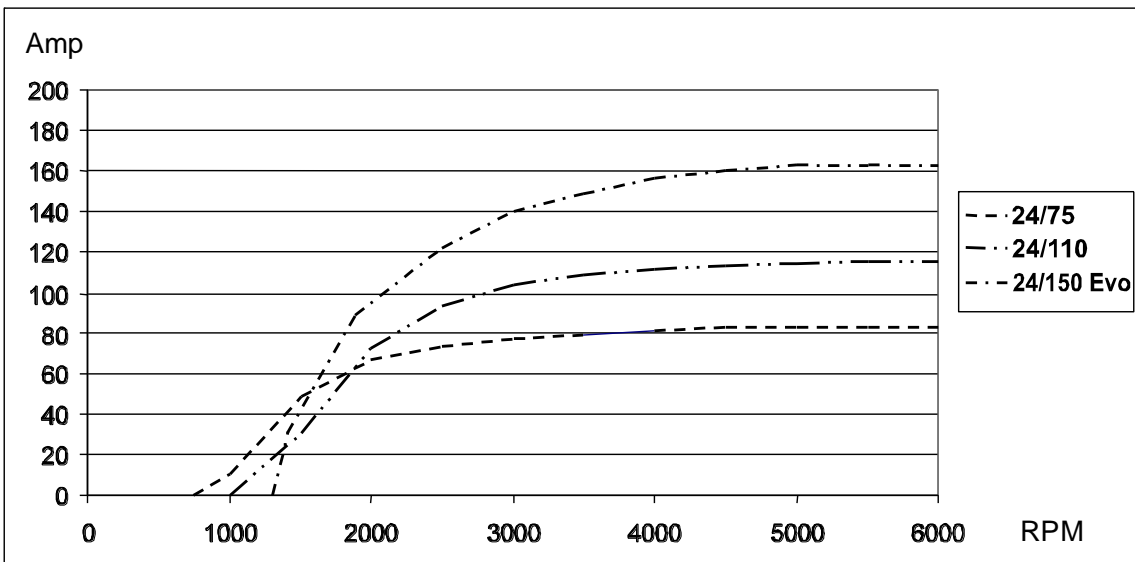
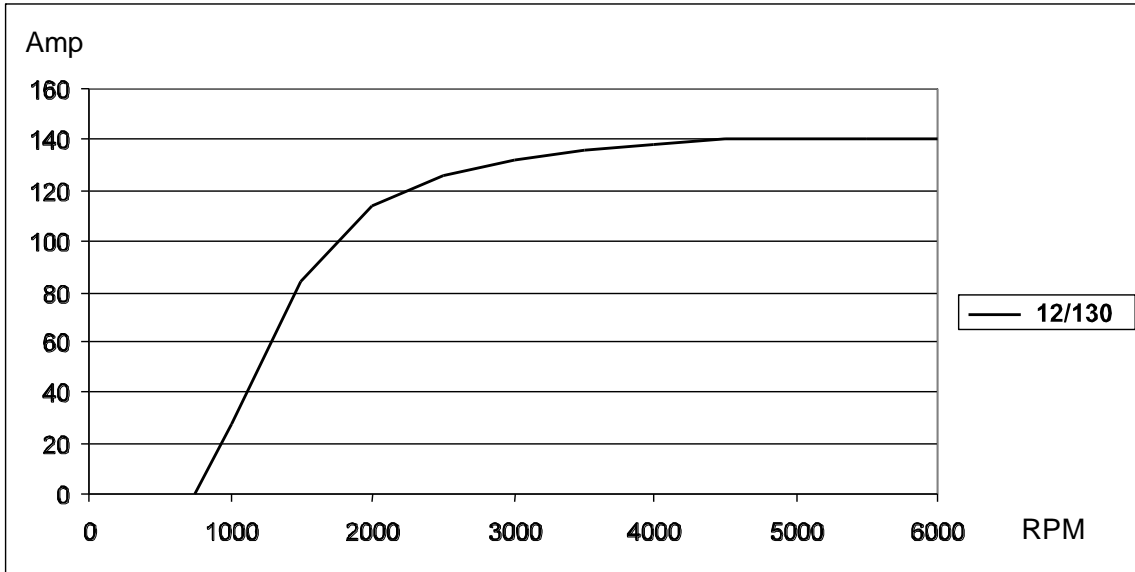

Output power is measured in combination with Alpha Pro III regulator at nominal voltage (25°C)

This page intentionally left blank

This page intentionally left blank



Europe, Middle East & Africa

Technical Support

T: +31 (0) 20 34 22 100

E: ts.emea@OneASG.com

Location & Shipping

Navico Group EMEA

Snijdersbergweg 93

1105 AN Amsterdam

The Netherlands

Americas & Caribbean

Technical Support

T: +1 262 293 0600 / 800 307 6702

E: tech.mastervolt@OneASG.com

Location & Shipping

Navico Group US

N85 W12545 Westbrook Crossing

Menomonee Falls, WI 53051

United States

Asia Pacific

Technical Support

T: +64 9 415 7261

E: technical.apac@OneASG.com

Location & Shipping

Navico Group APAC

42 Apollo Drive

Rosedale, Auckland 0632

New Zealand

Document version: 10000014840/08 (February 24)

Copyright ©2024 Navico Group EMEA B.V. All rights reserved.