

N3.21

SPECIFICATIONS

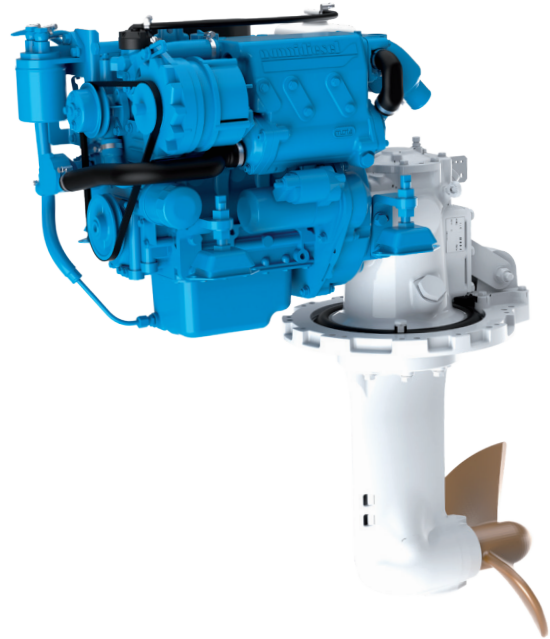
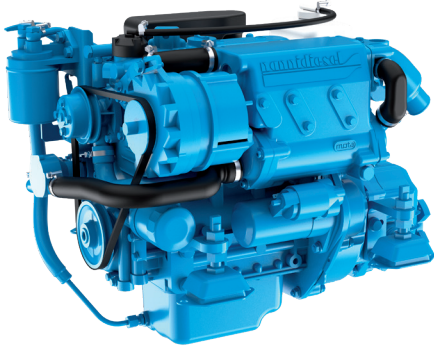

Power at crankshaft	14.61 kW [19.6 hp]
Displacement	0.719 l [44 in ³]
Configuration	3 cylinders in line
Operation type	4 strokes Diesel
Bore & Stroke	67 x 68 mm [2.64 x 2.68 in]
Compression ratio	23.5 : 1
Rated speed	3600 rpm
Idling speed	1050 rpm
Peak torque	44.1 Nm
Peak torque speed	2450 rpm

Engine base	Kubota
Fuel system	Mechanical Indirect injection
Air intake	Natural
Cooling	Closed cooling with heat exchanger
Max mounting angle	15° Front down 15° Front up
Alternator	12 Volt 70 Amp
Rating	M5
Emission compliance	RCD 2013/53/EU EPA marine Tier 3 BSO 2
Dry weight	
with TMC40	106 kg [233 lbs]
with Sail Drive SP60	142 kg [313 lbs]

N3.21

14.61 kW [19.6 hp] at 3600 rpm

TECHNICAL DESCRIPTION

ENGINE BLOCK

- 3 Cylinders in line
- Gear-driven valve train
- Water cooled exhaust manifold

FUEL SYSTEM

- Mechanical governor
- Cam driven in-line injection pump
- Fuel feed pump with hand primer
- Fuel filter

LUBRICATION SYSTEM

- Replaceable full-flow oil filter
- Oil dipstick
- Oil cooler

COOLING SYSTEM

- Closed cooling with heat exchanger
- Gear driven self-priming raw water pump
- Coolant circulating pump
- Water cooled exhaust elbow

ELECTRICAL SYSTEM & INSTRUMENTATION

- 12 V Electrical system
- 12 V / 70 A alternator
- Electric starter motor
- Electric stop function
- Instrumentation panel, including
- Start/Stop, tachometer & alarms
- Extension cable harness with plug-and-play

AIR INTAKE

- Mounted air cleaner

OTHER FEATURES

- Flexible engine mounting
- Bracket for control cables

OPTIONAL EQUIPMENTS & ACCESSORIES

- Keel cooling adaptation
- Complete marine propulsion systems
- Throttle and shift controls
- Additional instrumentation, Flying bridge extension harness
- Polyester frame (Sail Drive version)
- Engine mounting adaptation
- Two pole electrical system
- Water boiler systems
- Stuffing box connections
- Complete fuel systems
- Complete exhaust systems

RATINGS

- Up to 1000 annual operating hours
- Load factor up to 35%
- Full power for no more than 30 minutes out of each 8 hours of operation. The remaining time must be at, or below cruising speed

TRANSMISSIONS

SHAFT LINE

- TMC40
- TTMC35A

SAIL DRIVE

- Sail Drive SP60
- Contact your Nanni representative for more details and availability about transmissions types and models range.

PERFORMANCE CURVES

POWER AT CRANKSHAFT

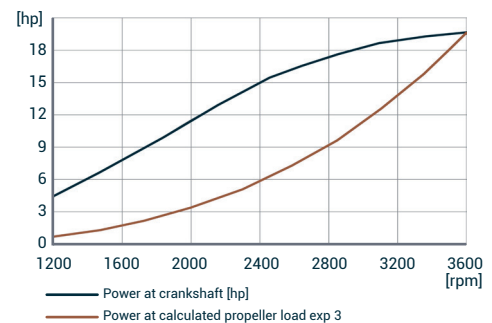

TORQUE AT CRANKSHAFT

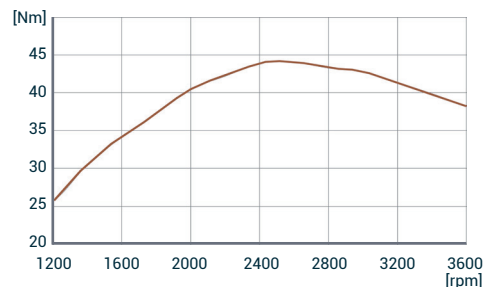

FUEL CONSUMPTION

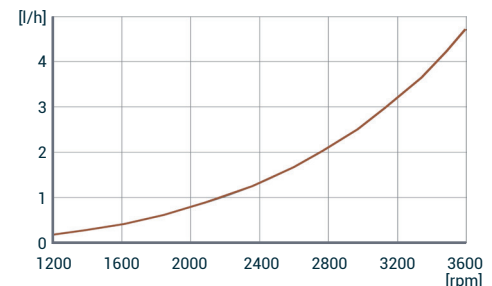

DIMENSIONS WITH SP60 / TMC40

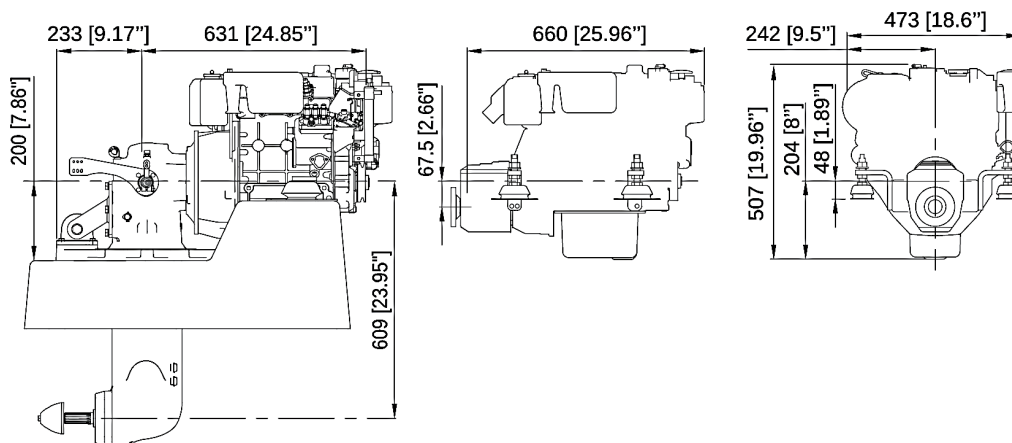

NANNI INDUSTRIES S.A.S.

11, Avenue Abbé Mariotte
33260 La Teste - France
Tel +33 (0)5 56 22 30 60
www.nannienergy.com

NANNI SRL

Via degli Olmetti, 44/A
00060 Formello - Roma - Italia
Tel +39 06 30 88 42 51
www.nannienergy.com

Technical data according to ISO 8665. This document is not contractual. Nanni reserves the right to modify any of the characteristics stated in this document without notice, in a constant effort to improve the quality of its products. Images and illustrations may show non standard equipments. All combination of equipment & accessory are not available.

DGBXXC01003B