

Phase Three Three Stage Smart Charger

Installation/Operation Manual Models: PT-24-20U & PT-40U

Table of Contents

Section Topic	Page
QUICK REFERENCE GUIDE.....	2
I) GENERAL INFORMATION.....	3
II) IMPORTANT SAFETY INFORMATION.....	3
III) INSTALLATION.....	4
A) Materials Provided.....	4
B) Location.....	4
C) Mounting.....	5
D) DC Output Wiring.....	5
E) Multiple Unit Parallel Wiring.....	6
F) AC Input Wiring.....	6
IV) OPERATION.....	7
A) Three Stage Charge Regimen.....	7
B) Time-Out Circuit.....	7
C) Gel-Cell/Leac-Acid Selector Switch.....	8
D) Remote Panel Option: 12 Volt Model.....	8
E) Temperature Compensation Option.....	8
F) Cooling Fan & Filter Maintenance.....	9
G) Output Ammeter.....	9
H) Power-On Indicator.....	9
V) APPLICATION NOTES.....	10
A) Start-Up.....	10
B) Constant Versus Occasional Use.....	10
C) Proper Load Sizing.....	10
D) Operation with Enging.....	10
E) Operation as a DC Power Supply (Stand Alone DC Power Source).....	10
VI) TROUBLE SHOOTING.....	11
VII) SPECIFICATIONS.....	12
VIII) BATTERY CARE TIPS.....	12
IX) REFERENCE APPENDIX.....	13
X) UNIT DIMENSIONAL DRAWING.....	14



M-PT2420U/40ULF-FIL
As of 080114

Quick Reference Drawing

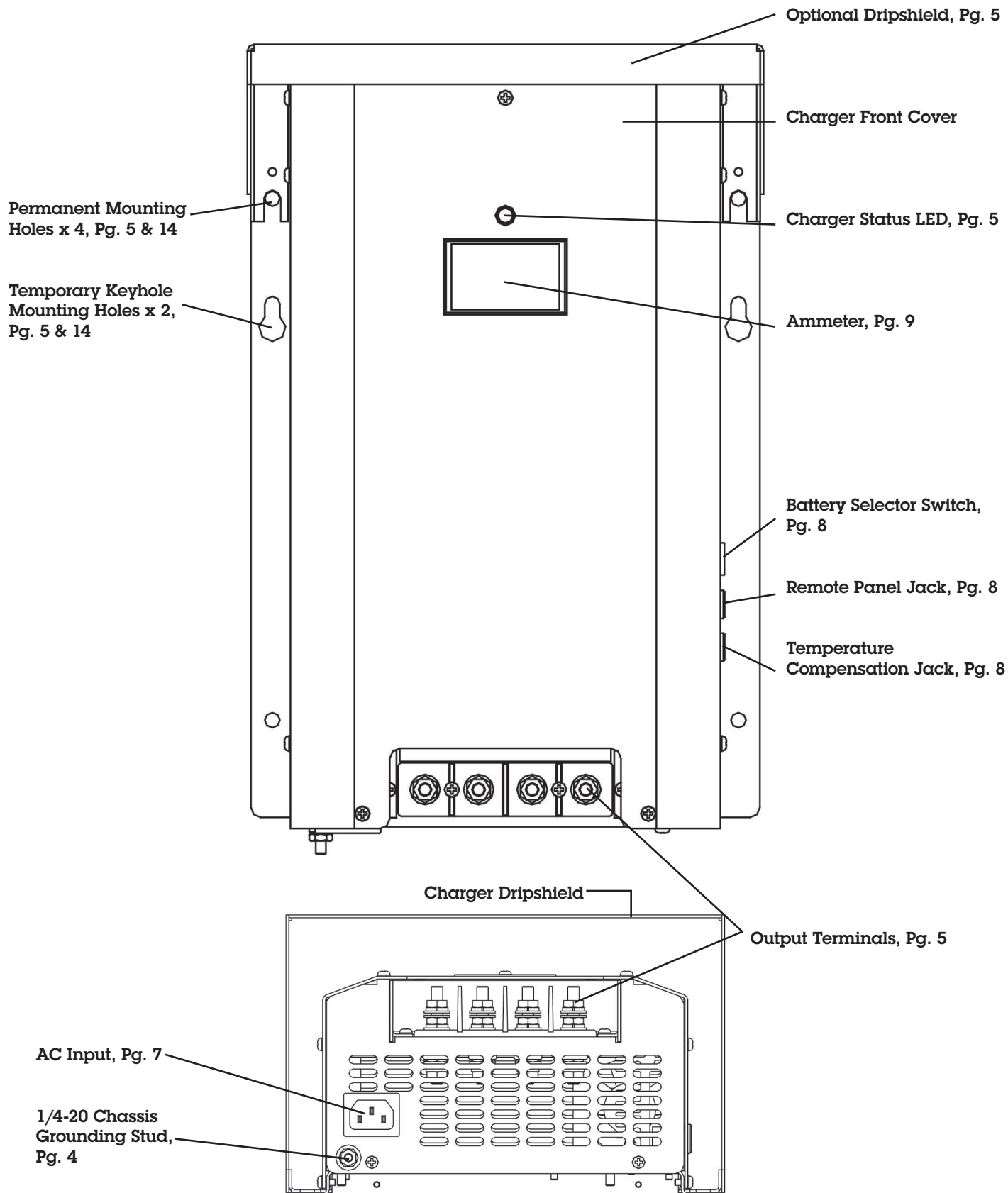

1) General Information

Your Phase Three™ Series Battery Charger represents a new phase in charger design and performance, employing "smart" switching circuitry which puts batteries through the optimum three-stage charge process, adapts for gel-cell or lead-acid batteries, features precise voltage compensation for varying battery temperature, is rated for continuous duty and is housed in rugged stainless steel cover coated with a durable white powder coat finish.

Following is a brief listing of some of the more important features/options of your Phase Three Charger. Each is fully detailed later in this manual:

- Three step "smart" charging: bulk, absorption, float
- Gel-cell/lead-acid switch selects optimum charge/float voltages based on battery type
- Multiple output banks charge independently based on demand
- 115/230 VAC, 50-60 Hz input – can be used anywhere in the world
- Current limited – prevents damage in case of over loading
- Thermally controlled cooling fan allows continuous operation at full-rated output
- High charge voltage time-out circuit prevents over charging during continuous high amperage demand
- Optional temperature compensation sensor fine tunes output voltage based on battery temperature
- Optional Remote Panel (12 volt only) allows battery voltage monitoring of 1 or 2 banks, indicates battery voltage too high/too low via multi segment LED bar graph
- Use as a power supply without in-line battery; allows continued use of DC powered electronics (when AC is available) in the event that batteries must be taken off-line or removed
- Built to last - rugged stainless steel and aluminum case powder coated case with marinized internal circuitry; optional-use dripshield provided

In addition, your Phase Three Charger carries a full two year warranty against defects in materials or workmanship from the date of purchase. Careful attention to these instructions should help you enjoy years of trouble-free service.

II) Important Safety Instructions

1. **SAVE THESE INSTRUCTIONS** – This manual contains important safety and operating instructions for the Phase Three Battery Charger.
2. Before using this battery charger, read all instructions and cautionary markings on (1) the battery charger, (2) the battery, and (3) product powered by the battery.
3. **CAUTION** – To reduce the risk of injury, charge only 6 cell (12 volt models) or 12 cell (24 volt models) gel-cell or lead-acid rechargeable batteries. Other types of batteries may burst, causing personal injury and damage.

4. Do not expose charger to rain or spray.
5. Use of an attachment not recommended or sold by NEWMAR may result in a risk of fire, electric shock or injury to persons.
6. To reduce the risk of damage to the electric plug and cord (if plugged into an AC outlet), pull by plug rather than cord when disconnecting the charger.
7. Make sure the cord is located so that it will not be stepped on, tripped over, or otherwise subjected to damage or stress.
8. An extension cord should not be used unless absolutely necessary. Use of an improper cord could result in the risk of fire and electric shock. If an extension cord must be used, make sure:
 - A) That pins on the plug of the extension cord are the same number, size and shape as those on the plug of the charger.
 - B) That the extension cord is properly wired and in good electrical condition.
 - C) That the wire size is large enough for the AC amperage rating of the Phase Three Charger. Refer to the **SPECIFICATIONS SECTION** to determine the full load input current of your Phase Three Charger, and then use the chart below to determine the correct gauge wire for any extension cord used.

RECOMMENDED MINIMUM AWG SIZE FOR EXTENSION CORDS FOR PHASE THREE BATTERY CHARGER					
AC Input Rating, Amperes		Length of Cord, Feet			
Equal to or greater than	but less than	25	50	100	150
Size of Cord (AWG)					
4	6	16	16	14	12
6	8	16	16	12	10

9. Do not operate the charger with a damaged cord or plug; replace them immediately.
10. Do not operate the charger if it has received a sharp blow, been dropped, or otherwise damaged; take to a qualified serviceman.
11. Do not disassemble the charger; take it to a qualified serviceman when service or repair is necessary. In correct reassembly may result in a risk of electric shock and fire.
12. To reduce the risk of electric shock, disconnect the charger from AC source before attempting any maintenance or cleaning.



WARNING – RISK OF EXPLOSIVE GASES

1. WORKING IN THE VICINITY OF A LEAD-ACID BATTERY IS DANGEROUS. BATTERIES GENERATE EXPLOSIVE GASES DURING NORMAL BATTERY OPERATION. FOR THIS REASON, IT IS OF THE UTMOST IMPORTANCE THAT BEFORE INSTALLING AND USING YOUR CHARGER, YOU READ THIS MANUAL AND FOLLOW THE INSTRUCTIONS EXACTLY.

2. To reduce the risk of battery explosion, follow these instructions and those published by the battery manufacturer and by the manufacturer of any equipment you intend to use in the vicinity of the battery. Review cautionary markings on these products and on the engine.

PERSONAL PRECAUTIONS

1. Someone should be within range of your voice or close enough to come to your aid when you work near a lead-acid battery.

2. Have plenty of fresh water and soap nearby in case battery acid contacts skin, clothing, or eyes.

3. Wear complete eye and clothing protection. Avoid touching your eyes while working near a battery.

4. If battery acid contacts skin or clothing, wash immediately with soap and water. If battery acid enters the eye, immediately flood eye with running cold water for at least 10 minutes and get medical attention immediately.

5. NEVER smoke or allow a spark or flame in the vicinity of the battery or engine.

6. Be extra cautious to reduce the risk of dropping a metal tool onto the battery. It might spark or short-circuit the battery or other electrical part and cause an explosion.

7. Remove personal metal items such as rings, bracelets, necklaces, and watches when working with a lead-acid battery. A lead-acid battery can produce a short-circuit high enough to weld a ring or the like metal, causing a severe burn.

8. Use the battery charger for charging gel-cell or flooded lead-acid batteries only. It is not intended to supply power to a low voltage electrical system other than in a starter-motor application. Do not use the charger for charging dry-cell batteries that are commonly used with home applications. These batteries may burst and cause injury to persons and damage to property.

9. NEVER charge a frozen battery.

PREPARING TO CHARGE

1. Be sure the area around the battery is well ventilated.

2. Clean battery terminals. Be careful to keep corrosion from coming in contact with eyes.

3. Add distilled water in each cell until battery acid reaches level specified by battery manufacturer. This helps purge excessive gas from cells. Do not overfill. For a battery without cell caps, carefully follow manufacturer's recharging instructions.

4. Study all battery manufacturers' specific precautions such as removing or not removing cell caps while charging and recommended rates of charge.

GROUND AND AC POWER CORD CONNECTION

1. The charger should be grounded to reduce risk of electrical shock.

2. The Phase Three Charger is provided with IEC certified AC power cord. If, for any reason, the plug on the cord must be changed or replaced, observe color coding of the AC wiring as follows:

Brown.....AC Hot (fused)
Blue.....AC Neutral
Green.....AC Ground (safety/earth)

The charger must be plugged into an outlet that is properly installed and grounded in accordance with all local codes and ordinances.

DANGER: Never alter the AC cord or plug provided, unless it is absolutely necessary for use with the AC outlet which conforms to all relevant electrical codes. Any modification of the cord must only be done by a qualified electrician. Improper cord/outlet connection can result in a risk of electrical shock.

EXTERNAL CONNECTIONS TO THE CHARGER SHALL COMPLY WITH UL RECOMMENDATIONS AND/OR UNITED STATES COAST GUARD ELECTRICAL REGULATIONS (33CFR183, WSUB-PART D)

THE INSTALLATION AND PROTECTION OF VESSEL WIRING ASSOCIATED WITH BATTERY CHARGERS SHALL COMPLY

WITH ABYC STANDARDS E-11) AC & DC ELECTRICAL SYSTEMS ON BOATS, AND A-31) BATTERY CHARGERS & INVERTERS

III) INSTALLATION

A) Materials Provided

The Phase Three charger is provided completely assembled and ready for installation. Because of numerous installation variables, the installer will need to provide four suitable 1/4" mounting screws/washers, as well as DC output wiring and connectors. Proper sizes and gauges for the wire and connectors are noted in **Section III-D** following.

B) Location

The charger should be mounted on a wall, bulkhead or other suitable mounting surfaces as close to the batteries to be charged as possible. Do not mount the charger directly over the batteries as fumes may cause excessive corrosion. The area should be well ventilated and free from excessive moisture, exhaust manifolds, and battery fumes.

Vertical mounting is preferred in order to allow the dripshield to protect the charger from any moisture which may fall onto the charger. However, vertical mounting is acceptable since the charger is forced-air cooled. It should not be located where there is a possibility of debris being drawn into the unit through



the fans.

If the charger is located in an extreme heat area, such as an unventilated engine room, and the cooling fans are unable to maintain proper operating temperature, output power will automatically be reduced to protect the charger. For maximum performance, the charger should not be located in an area of extreme high temperature.

IMPORTANT: Although the charger is constructed of materials and in a manner which make it highly resistive to the corrosive effects of moisture in the environment, the charger is not waterproof. Do not mount the charger where there is a possibility of water entering the unit. Evidence of water entry into the charger will void the warranty.

Multiple Charger Installation – Ventilation Mounting Notes

When installing two PT battery chargers near each other it's important to avoid hot air re-circulation, i.e. hot air exhaust from one battery charger being drawn in to the adjacent battery charger's air intake which can cause shut down due to over-temperature which will shorten the life of the battery charger.

Side By Side Mounting

Mounting identical chargers side by side with flanges touching is OK, however if chargers with top end located air filters are mounted adjacent to chargers without air filters, a minimum separation of 8" (200 mm) is recommended. If this is not possible due to space constraints, installing a separator plate between the two chargers is recommended. The separator should extend at least 2" (50 mm) beyond the drip shield front edge and have a height that extends at least 2" more above and below the charger's height, including drip shield if installed.

Vertical Mounting

When mounting one charger directly above another maintain 16" vertical separation between the units if the drip shield is installed on the lower unit. If drip shield is not installed on lower unit, maintain 24" clearance.

C) Mounting

The charger may be mounted on either a metal or non-metal surface*. You will require four screws (wood or machine screws, depending on mounting surface) with washers, sized for 1/4" holes, to mount the charger, plus two temporary holding screws. Note that, in addition to the four permanent mounting holes in the flanges, there is a hole in each mounting flange which is "keyhole" shaped. This is provided to ease vertical installation.

*To comply with ABYC DC chassis grounding conductor (ABYC A-31), connect a suitable sized wire to the 1/4"-20 chassis grounding stud near AC cable connector.

Make a mark on the wall or bulkhead where each of the keyhole slots will be located. Then drive a screw about half-way in at each of these marks. Hang the charger onto the bulkhead using the "keyhole" slots. Doing this will save you from having to support the charger's weight while you are driving in the four permanent mounting screws. Note: The "keyhole" slots may be used for additional support screws but they are not to be used as permanent mounting points, by themselves.

D) DC Output Wiring

Note: Only qualified service personnel should access the output terminals of the charger.

Whether working with existing battery charger output wires or installing new ones, make sure the battery(s) is disconnected from these wires before connecting them to the charger's output terminals

For a secure installation, DC output wires must be attached with 1/4" ring crimp lug terminals sized appropriately to fit wire gauges as listed below

The DC wire size table below may be used to determine the correct gauge wire, based on the model you have and the length of the wire run from the charger to the batteries. Once the output wiring has been attached to the chargers output posts, install the clear plastic terminal cover provided with the charger

DC Wire Size Table			
Model	DC Wire Size Table		
	10	15	20
Wire Gauge AWG (mm)			
PT-24-20U	#10 (6mm)	#10 (6mm)	#8 (10mm)
PT-40U	#6 (16mm)	#4 (25mm)	#2 (35mm)
* Based on ABYC 3% voltage drop table and NEC minimum wire size chart			

Figure 1: Simple D.C. Wiring (Preferred Method

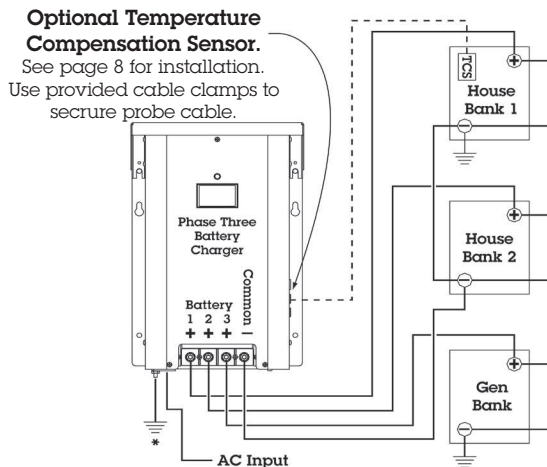

* Per ABYC A-31: A D.C. chassis conductor shall be connected from the case of the battery charger to the engine negative terminal or its bus, and must not be more than one size under that required for the D.C. current carrying conductor and not less than 16 AWG

Note: The diagram Figure 1 does not illustrate a complete system. Refer to ABYC standards E-11 AC & DC electrical system on boats.

Note: If batteries are closer to charger than battery switch, wire directly to battery posts.

It is recommended that DC wiring from the charger to the batteries be as direct as possible. Line voltage loss and electronic noise interference of sensitive electronics are possible if the charging leads are routed through a central electrical distribution panel. Any elaborate configurations are best left to a qualified electrician.

ENSURE THAT LEADS ARE PROPERLY FUSED AT THE BATTERY. (REFER TO ABYC RECOMMENDATIONS. SEE REFERENCE APPENDIX AT THE END OF THIS MANUAL FOR ABYC CONTACT INFORMATION.)

Ensure that your connections are tight and that correct polarity is carefully observed at all times. The battery posts should be free of any rust or corrosion.

IMPORTANT NOTE: EVEN MOMENTARY REVERSE POLARITY CONNECTION MAY SEVERLY DAMAGE YOUR CHARGER. THE POSITIVE (+) TERMINAL MUST BE WIRED TO THE POSITIVE POST OF THE BATTERY AND THE NEGATIVE OR COMMON (-) TERMINAL TO THE NEGATIVE POST OF THE BATTERY OR COMMON BUS.

CAUTION: Do not attempt to increase battery bank capacity by splitting the output of one of the banks with a diode-type battery isolator. Undercharging may occur on the output bank, as a result.

If you wish to add another isolated battery bank, use of NEWMAR's Battery Integrator is recommended. Contact the factory for details. Be sure to replace the clear plastic terminal cover to prevent accidental shorting of the output terminals in the future.

An Important Note about the DC Output Fuse(s): internal DC wiring is protected by the internal DC output fuse(s). The current limiting circuit of the Phase Three Charger should prevent these fuses from blowing under normal operating conditions. If the DC fuse(s) blow, this may indicate a reverse polarity hook-up or an internal short.

Always disconnect AC to the charger before checking fuses. To check or replace the DC fuse, the cover must be removed. To do this requires removal of four screws from the front of the unit and three screws on each side. The DC fuse is mounted on the main circuit board. Be sure to replace with the same type and value as indicated on the fuse.

If the battery was connected to the charger backwards, the fuse should blow to protect DC wiring, however damage to internal components may also have occurred. If the replacement fuse blows, return the charger to an electronics service professional or to the factory for a thorough inspection.

Note: The internal fuses do not provide protection if there is a short in the wiring between the charger and the battery. The battery is itself a power source and charging leads should be fused at the battery per ABYC standards.

Figure 2: Wiring with Battery Switch

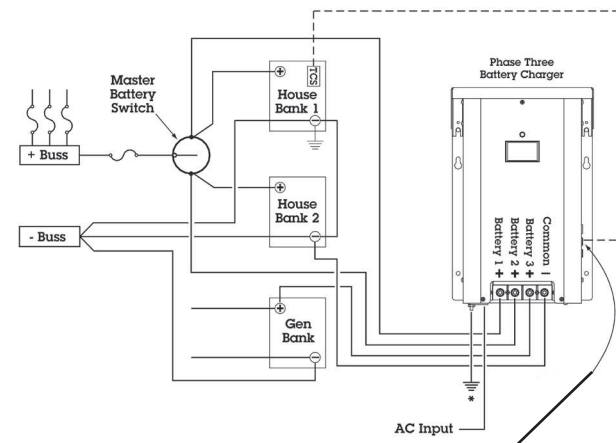

Optional Temperature Compensation Sensor. See page 8 for installation. Use provided cable clamps to secure probe cable.

* Per ABYC A-31: A D.C. chassis conductor shall be connected from the case of the battery charger to the engine negative terminal or its bus, and must not be more than one size under that required for the D.C. current carrying conductor and not less than 16 AWG

Note: The diagram Figure 1 does not illustrate a complete system. Refer to ABYC standards E-11 AC & DC electrical system on boats.

E) Multiple Unit Parallel Wiring

If increased power or system redundancy is required, a second charger may be wired in parallel. The unit is diode protected so it will not be damaged by feedback from the second unit and current limiting will prevent overloading in the case of a failure of one of the units.

Observe the following guidelines when wiring a parallel unit.

- 1) Use another identical charger model. Do not use a different charger model, either from NEWMAR or from another manufacturer.
- 2) Wire length and gauge and wire lug size must be identical for each charger to ensure proper load sharing.
- 3) Wire gauge for each charger must be the same used as if a single charger were wired into the system itself.

F) AC Input Wiring

NOTE: (For marine applications) THE INSTALLATION AND PROTECTION OF VESSEL WIRING ASSOCIATED WITH BATTERY CHARGERS SHALL COMPLY WITH ABYC STANDARDS E-11) AC & DC ELECTRICAL SYSTEMS ON BOATS, AND A-31) BATTERY CHARGERS & INVERTERS

These models are provided with an IEC certified AC cord which may be plugged into the charger and a proper outlet. If the plug is not suited to the available outlet, 1) obtain an IEC cord with appropriate plug or 2) obtain the correct plug for the outlet and install it on the provided IEC cord. When installing the plug, pay careful attention to the pin wiring as follows:

Brown.....AC Hot (fused)
 Blue.....AC Neutral
 Green (or Green with Yellow Stripe)...AC Ground (safety/earth)

As shipped from the factory, the AC input is "universal" and will accept AC voltage in the range of 90-264 VAC, 47-63 Hz.

A power cord cable clamp has been provided to prevent accidental disconnect of the AC cord. After the plug has been inserted into the charger, snap the pre-formed clamp around the AC input cable as close to the insertion point as practicable and use a screw to fasten the clamp tightly to the wall or bulkhead on which the charger is mounted.

Hard Wiring AC Input

If desired, the AC input to your charger may be hard-wired directly to the AC distribution panel. Install the charger end of the provided input cord as described above, then cut off the plug and splice onto three conductor marine-grade cable with crimp but connectors, observing color codes and fuse/circuit breaker ratings as above. For all models, use minimum 16 AWG cable.

All charger wiring should be made in accordance with UL, U.S. Coast Guard and/or ABYC regulations and recommendations, as well as all relevant local codes. See REFERENCE APPENDIX for sources.

AC input for the charger must be plugged into an appropriate, over-current protected three prong outlet OR routed through a separate dedicated fuse or circuit breaker on an AC distribution panel with proper safety/earth chassis ground in accordance with all local codes and ordinances.

CAUTION (230 VAC applications only): If AC input is derived from a source consisting of two HOT leads (phase-to-phase 230 VAC input voltage), an external fuse or circuit breaker must be used to protect the unfused (formerly NEUTRAL, now HOT) lead.

A note about the AC Input Fuse: The AC input of your charger is protected by an input fuse located inside the unit. Due to the current limiting characteristics of the charger, it is highly unlikely that this fuse will blow unless a malfunction occurs within the charger. The fuse is not user replaceable. Replacement of the fuse must be preformed by a qualified service person.

All charger wiring should be made in accordance with UL, U.S. Coast Guard and/or ABYC regulations and recommendations, as well as all relevant local codes. See section IX) REFERENCE APPENDIX for sources.

IV) OPERATION

A) Three Stage Charge Regimen

The Phase Three Battery Charger features the three stage charge regimen which is widely recommended by battery manufacturers for allowing the fastest possible recharge time without loss of batteries' electrolyte (gel or liquid) which may be caused by sustained charging at higher voltages.

This three stage regimen is initiated each time AC is first applied, when drained batteries are most likely to be encountered. The regimen proceeds as follows:

1) Bulk Charge – When batteries are significantly discharged the charger responds initially by delivering a high amount of DC current, at or near the charger's maximum rated output, in order to rapidly replenish them. It is during this stage that charging current is maintained at a high level as battery voltage increases. Bulk charging continues until battery voltage reached the "charge" voltage level (where batteries are at about 75-80% of capacity). A current limit circuit prevents charger overload during this maximum output stage

2) Absorption Charge – During this second stage of the charge cycle, battery voltage is maintained at the "charge" voltage level. Output current begins to taper off as the battery plates become saturated. Charge voltage is maintained until the current sensing circuit detects that output current has tapered to about 5-15% of charger rating*. At this point, the batteries are at about 95% of full charge and the Phase Three charger switches to the third and final stage of the charge cycle.

***Note:** The absorption phase may also be ended by the time-out circuit. See section B following for a complete explanation of the purpose and functioning of the time-out circuit.

3) Float Charge – For extended battery life, the Phase Three then automatically switches to a lower float voltage level. This float charge keeps batteries at peak condition without overcharging. The charger may be left in this stage for months without attention (though periodic checks of electrolyte level in flooded batteries is recommended.)

FIGURE 3: Typical Charger Output Graph (into battery without load)

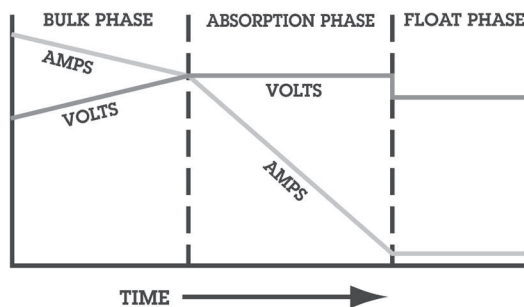

*Approximately 10 hours maximum at factory setting.

B) Time-Out Circuit

Batteries have a tendency to lose their electrolyte and may be damaged if they are maintained for long periods of time in the elevated voltage of the absorption phase. Therefore, the Phase Three Charger employs a special time-out circuit. This circuit is initialized each time AC is first applied to the charger and runs for a pre-set interval before forcing the charger to go into the float (lower voltage) mode. The functioning of the charger during this interval is as follows:

If the current demand of the batteries/load falls below 5-15 percent of the charger's output capacity prior to the circuit timing-out, the charger will automatically switch to the float

mode. (For instance, with model PT-40U, the charger will drop into float mode at about 2-6 amps output.) If demand rises to about 10-20 percent of capacity (4-8 amps with PT-40U, for instance), the charger will return to the elevated output of the absorption phase. This switching back and forth between modes may occur until the circuit times-out (8-10 hours after AC is first applied), after which the charger will remain at float voltage, until the circuit is re-initialized by turning the charger off and then on again.

Note: The Phase Three Charger is able to deliver its full rated output current while in float mode.

C) Gel-Cell/Lead Acid Selector Switch

According to most battery manufacturers, the ideal charging regimen for gel-cell and wet or flooded lead acid batteries differs somewhat.

The gelled electrolyte in a sealed battery may be lost or damaged by high voltage and, once lost, cannot be replaced as it can with a wet lead acid battery. Manufacturers of gel-cells usually recommend an ideal charge voltage which is slightly lower for a gel-cell than a lead acid battery.

However, when the charger is in the float voltage mode over lengthier periods of time, gelled electrolyte in a sealed battery is not susceptible to evaporation, as is the non-immobilized electrolyte of a wet lead acid battery. This evaporation can be accelerated by the applied voltage. Consequently, the ideal float voltage is slightly higher for a gel-cell than a lead acid battery.

The ideal charge/float regimen has been programmed into the Phase Three Charger for either sealed gel-cell or flooded lead acid batteries. Simply make the proper selection for your battery type via the slide switch on the right side of the charger. The switch positions are indicated on the front panel (up for Gel-Cell batteries, and down for Lead-Acid/AGM type batteries). Use a ball point pen or similar object to slide it into the correct position. The charger is shipped from the factory set for Lead-Acid/AGM batteries.

Note: A wide variety of batteries are available which do not conform to conventional descriptions as "gel-cell" or "lead-acid". You are advised to consult the manufacturer of your particular battery as to proper charging regimen, and use the battery type selection switch setting which most closely conforms to the recommended voltages.

See the **SPECIFICATIONS** section for the actual preset charge and float voltages for each battery type/charger model.

D) Remote Monitor Panel Option

A remote battery monitor (for 12 volt model, PT-40U only) is available from NEWMAR, model EVM-12-2, which enables you to monitor when the battery charger is "on" and the batteries' state of readiness at a glance of two (2) battery banks only. Red, yellow, and green bar LEDs indicate the batteries state of charge, and a green "Charger On" LED is illuminated whenever AC power is connected to the PT-40U. Flashing red bars indicate when High or Low voltage is detected. The display has a sleep mode to conserve power and gives periodic flashing indication

of the battery voltage level even when the boat or vehicle and the charger are off. In the event battery voltage drops to a critical level, the display will automatically come out of sleep mode into full operation to alert the operator.

The EVM-12-2 requires a 22-5 cable (NEWMAR part number 712-2205-0, sold by the foot). The EVM interface plugs into the EVM jack on the PT-40U and wires to the Charger's output.

E) Temperature Compensation Option

Because low battery temperature increases resistance to charging and high battery temperature reduces impedance, requiring a lower charge voltage, the ideal charging voltage will vary depending on the temperature of the battery's environment when it is being charged.

If a charger has a fixed output voltage which is ideal at, say 72° F that same output may cause a battery charged in consistently high temperature environment to be overcharged, resulting in excessive loss of electrolyte. Conversely, if the batteries are in a consistently cool environment, they may be chronically undercharged, resulting in sulfation of the battery plates. Either of these two conditions will shorten battery life.

Therefore, the Phase Three Charger is designed to utilize an optional remote sensor (available from NEWMAR, model TCS-12/24) which provides automatic temperature compensation. The remote sensor will signal the charger to fine tune its output voltage so that it is properly matched to the temperature of the battery/battery environment. The adjustment rate is approximately -3mV per cell per °C. (Note: The temperature compensation option is strongly recommended for sealed, valve-regulated or gel-cell batteries.)

The remote sensor is provided with 30' of cable (model TCS-12/24-40 is provided with 40' of cable). One end of the cable is plugged into the temperature compensation jack which is located on the right side of the charger. (See FIGURE 5.) The temp sensor jack is identified on the front panel. If additional cable length is required, additional cable is commonly available from most electronics supply retailers as Radio Shack/Tandy. Request a 6 conductor modular-to-modular line cord (part number 279-422, 25 feet long) and 6 pin modular in-line non-reversing coupler (279-423).

The sensor itself should be mounted on the inside of the battery box, or more ideally, mounted onto one of the batteries using a clamp or a small amount of silicon-type adhesive. The sensor has a hole in the center which will accommodate a #6 screw. If you have access to the exterior of a wall of the battery box, you may drill a hole in the wall of the box and run the screw through to mount the sensor onto the interior wall. Use caution when drilling so that you do not accidentally puncture the case of any battery inside the box.

Important note: When wiring multiple units in parallel (see section III-E) and using the temperature compensation option, you must use a separate sensor for each charger, and the sensors must be mounted close together in the same battery box or on the same battery for proper operation.



FIGURE 5: Temperature Compensation Sensor and EVM-12-2 Panel Installation

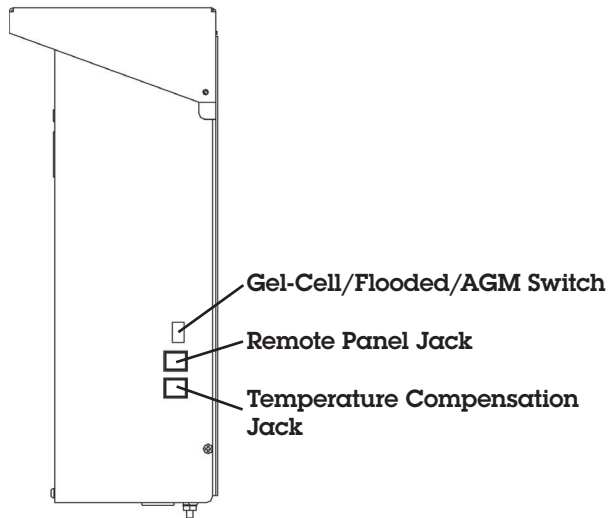

Temperature Compensation Charts:

Battery Temperature		Output V DC: 12 Volt Models			
		Charge		Float	
°F	°C	Gell-Cell	Lead-Acid	Gell-Cell	Lead-Acid
50	10	14.4	14.6	14.0	13.8
72	22.2	14.0*	14.2*	13.6*	13.4*
90	32.2	13.7	13.9	13.3	13.1

* Factory pre-set voltages without temperature compensation option installed.

Battery Temperature		Output V DC: 24 Volt Models			
		Charge		Float	
°F	°C	Gell-Cell	Lead-Acid	Gell-Cell	Lead-Acid
50	10	28.8	29.2	28.0	27.6
72	22.2	28.0*	28.4*	27.2*	26.8*
90	32.2	27.4	27.8	26.6	26.2

* Factory pre-set voltages without temperature compensation option installed.

To give some idea of the effect of the temperature compensation sensor, the chart on the following pages list the charge/float output voltages of the charger when no sensor is installed (or when batteries are at 72° F), and at cold (50° F) or hot (90° F) battery temperature with temp sensor installed:

F) Cooling Fan & Filter Maintenance

To maximize the life of the internal components and to allow continuous operation at full rating, the Phase Three Charger employs two integral cooling fans. The fans draw air through the top of the unit and expel it out the bottom to improve cooling (an optional dripshield is provided for water dripping protection). Note: Under most circumstances, the fans will be in operation when the charger is on. However, fan speed/audible may

vary under no load and/or ambient temperature conditions.

The charger is equipped with two air filters located on the top panel of the case, designed to reduce particulate matter from entering the charger by the intake of the cooling fans.

These filters should be removed periodically and rinsed with clean water to ensure adequate air flow, otherwise if the filter becomes clogged the charger will overheat and produce less power or shut down altogether and enter a thermal cycling mode.

The maintenance frequency will depend on the environment of the application, at minimum the filters should be inspected/serviced every 3 months. If the charger is mounted in a dusty, particle-filled, or oily atmosphere inspection and cleaning will need to be more frequent and you will need to set your maintenance schedule accordingly.

Filter cleaning/replacement procedure (see illustration below)

- 1) Disconnect ac power from the charger
- 2) If the provided drip shield has been installed above the charger it will need to be removed to access the filter: Remove the drip shield by loosening the upper mounting bolts and then slide the drip shield up and off of the battery charger.
- 3) Remove the filter retainer cap by pushing up on the rim of the cap and remove the filter.
- 4) Rinse/wash the filter and allow it to dry before replacing and securing the retainer cap.

Replacement Filters

If the filter is ever damaged a replacement kit is available from Newmar. Specify part number 999-9325-0. If obtaining filter from another source specify a 1/4" thick filter medium of 30 PPI density which you can cut to size.

Figure 4: Cooling Fans and Filter Maintenance

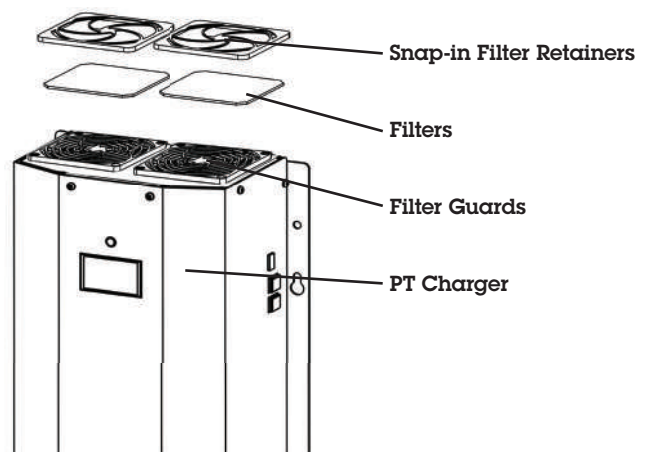

G) Output Ammeter

This will indicate total charging output current for all battery banks connected.

H) Power-On Indicator

This green LED will glow whenever the charger is receiving AC power.

V) Application Notes

A) Start Up

1) Before powering up your charger, check for tight electrical connections to each battery in your system. Switch off any DC loads on the batteries. Apply AC power. Observe the DC ammeter on the front panel. This meter displays the total DC output of the charger, through all banks. It will give some indication of the overall state of charge of your batteries. If the meter is reading mid-scale or higher, it is an indication that the batteries are in a relatively low state of charge. The charger, sensing this, is supplying high current to the batteries. If the meter needle is at or near the bottom of the scale the batteries are at or nearing full charge.

2) Apply a load to the charger by switching on some lights, a pump, or some other DC appliance. Observe the charger meter. It should read approximately the same as the expected current draw of the appliance. As current is demanded from the battery system, the charger will automatically increase its output in response to the increased load demand. When load current exceeds 10-20% of the charger's rated capacity, the charger will go into the absorption mode and remain there until current drops below 5-15% of capacity or until the time-out circuit cycle is complete.

B) Constant Versus Occasional Use

In general, it is recommended that the charger be left connected continuously to the AC distribution system so that it will be in operation whenever AC is available. This will maintain batteries at peak voltage and will automatically compensate for the natural self-discharge of the battery system. When a load is applied to the battery system, the charger's output will automatically increase to supply the current which would otherwise draw battery voltage down. Repeatedly allowing batteries to become completely discharged before recharging will greatly shorten their life. Leaving the charger on continuously will prevent this.

While the output regulation of the charger will minimize battery gassing and water loss, monthly checks of the electrolyte level (for wet lead acid batteries) are still strongly recommended. Some water loss is an inevitable aspect of the charging process, and maintaining the correct electrolyte level in your batteries is the most important you can do to assure their maximum performance and long life.

C) Proper Load Sizing

The Phase Three Charger is rated for continuous duty (e.g., the PT-40U can deliver up to 40 amps continuously, 24 hours a day, seven days a week). While the charger cannot be damaged by overloads that exceed this continuous rating, excessive load demands may draw battery voltage down faster than the charger can resupply it. If the battery voltage continues to drop and the output current is at maximum while the charger is in service, check to see that your average DC loads are not exceeding the charger's rated output. If they are, you may wish to consider adding another charger in parallel to provide sufficient power for your requirements. (See section III-E, Multiple Unit in Parallel Wiring.)

D) Operation with Engine

It is perfectly acceptable to allow the charger to remain on when the engine is started and while it is running. The current limit feature of the Phase Three Charger will protect against any damage due to the high current demands of the engine cranking. Output diodes will prevent any back-feed of current into the charger from the alternator while the engine runs.

As the alternator starts to charge the battery, the charger output will decrease. When the battery voltage exceeds the rated output voltage of the charger, it will shut off and stay off as long as the batteries are in this high state of charge. If the battery voltage should drop below the charger's rated output voltage, it will automatically return to service.

E) Operation as a DC Power Supply (stand alone DC Power Source)

Most battery chargers are not suitable for powering electronic devices directly, without a battery attached to the output, as the high ripple and pulsing DC output (i.e., rectified AC output) can interfere with the operation of the device. The Phase Three charger is different. It employs a circuit that produces an extremely well-filtered DC output. Therefore the charger is able to power virtually any DC powered device (within the unit's rating) without the battery attached in-line (if, for instance, the battery must be removed for any purpose and AC is still available). All but the most sensitive DC powered electronic devices will function as normally as if powered by a battery. In addition, the current limiting circuitry enables the charger to handle the high start-up surges associated with inductive loads, such as DC motors in radar sets.

VI) TROUBLESHOOTING

Condition	Possible Cause	Solution
A) Batteries are not coming up to full charge.	<ol style="list-style-type: none"> 1) Extremely discharged batteries requiring long recharge time. 2) Charger limiting its output due to overload or over temperature conditions. 3) Fan not operating properly causing charger to protect against over-heating by shutting off. 	<ol style="list-style-type: none"> 1) Turn off all D.C. loads and allow charger 24-48 hours to recharge batteries. See section IV-B for explanation of time-out circuit. 2) Reduce D.C. load and/or determine cause of over temperature state (See section III-B, "Location"). 3) Return for analysis/repair by servicing dealer where charger was purchased or contact NEWMAR for a Return Materials Authorization number.
B) Charger continues to charge at 3 amps or more – does not taper back into charge.	<ol style="list-style-type: none"> 1) DC load drawing current from batteries (not a problem condition). 2) Bad cell in one of the batteries to which charger is connected. 	<ol style="list-style-type: none"> 1) Turn off main battery switch to DC electrical panel or turn off all DC loads if you wish to confirm charger will output minimal amperage to fully charge batteries. 2) Check for shorted cell in all wet lead-acid batteries using a hydrometer. Replace battery if cell is shorted. Refer to manufacturer for testing maintenance-free batteries.
C) Charger does not charge.	<ol style="list-style-type: none"> 1) Charger is not receiving AC input voltage or is not receiving correct AC input voltage. 2) Charger output is not properly connected to batteries. 3) Blown wiring fuse. 4) Defective charger. 	<ol style="list-style-type: none"> 1) Using a voltmeter, confirm, AC input voltage, check input connections. 2) Refer to DC wiring installation diagram for proper connections to batteries. 3) Replace with another of correct value (see section III-D, "DC Output Wiring"). 4) Return for analysis/repair by servicing dealer where charger was purchased or contact NEWMAR for a Return Materials Authorization number.
D) Charger repeatedly blows input fuse or circuit breaker feeding AC power to charger	<ol style="list-style-type: none"> 1) Short in AC wiring feeding power to charger 2) Internal short 	<ol style="list-style-type: none"> 1) Locate and correct wiring short 2) Return for analysis/repair by servicing dealer where charger was purchased or contact NEWMAR for a Return Materials Authorization number.
E) Reverse polarity connection to charger has caused charger to stop charging.	DC Output fuse and possibly other components blown.	Replace output fuse with another of correct value. If fuse blows, return to servicing dealer or contact NEWMAR for Return Materials Authorization.
F) High output voltage measured across charger output terminals.	Batteries not connected to charger. It is normal to read ½ volt higher across any output bank when no batteries are connected.	Check for tight connection of charging leads from charger to batteries.

VII) Specifications

INPUT RANGE (ALL MODELS): 90-264 VAC; 47-63 HZ (automatic)

OUTPUT BANKS (ALL MODELS): 3

Model	Input Amps 115/230 VAC	Output	
		Volts	Amps. Cont.
PT-40U	6.8/3.4	12	40
PT-24-20U	6.8/3.4	20	20

	12 Volt Model		24 Volt Model	
	Charge	Float	Charge	Float
Setting	@ 50% Load	@ 1 amp Load	@ 50% Load	@ 1 amp Load
Gell-Cell	14.0 VDC	13.6 VDC	28.0 VDC	27.2 VDC
Lead Acid	14.2 VDC	13.4 VDC	28.4 VDC	26.8 VDC

Temperature Compensation: -5mV per cell per °C

Temperature Ratings: -20° C to + 60° C; Derate linearly from 100% @ 50° C to 60% @ 60° C

Case Size/Weight: 13.85" H* x 9.5" W x 4.8" D* / 11 Lbs.
35.2" x 24.1 x 12.2 (cm) / 5 Kgs.

* With drip shield installed, add .75" (1.9 cm) to the height and 1.35" (3.4 cm) to the depth.

Protection Features: Input fuse; Output fuse for reverse polarity protection; Current limiting; Automatic high temperature power reduction; Time and load controlled high rate charge circuit; Ignition protected; IP-21

VIII) BATTERY CARE TIPS

Regular maintenance and proper care will assure you reliable service from the most depended upon and sometimes most neglected items, your batteries and battery charger. NEWMAR battery chargers are designed to keep your batteries fully charged but your batteries also need proper regular maintenance to provide a maximum life of service.

ALWAYS READ AND FOLLOW THE BATTERY

MANUFACTURER'S INSTRUCTIONS

Battery Installation

Batteries must be securely mounted to prevent them from falling over when the vehicle or boat is in motion. A loose battery can do serious damage. Batteries should be mounted in a battery box to contain any acid spill. Batteries give off a certain amount of hydrogen gas when they are charging. When concentrated, this gas is highly explosive. Therefore, make sure they are in an accessible place with adequate ventilation for any hydrogen gas discharge.

Cleaning Batteries

Dirt and electrolyte salts can build up on the top of your batteries. This accumulation conducts electricity stored in the battery

and can cause the battery to discharge by itself. Therefore, at least twice a year, it is a good idea to disconnect the battery cables and scrub the battery with a baking soda solution. Rinse with fresh water and dry with a clean cloth.

You may wish to purchase a set of terminal post corrosion prevention rings. These are alkali-saturated felt rings that slip over the battery post to reduce corrosion. Do not apply grease to any part of the battery terminals, but you may use an occasional light spray of silicone lubricant.

Routine Checks and Maintenance

Batteries should periodically be "exercised" (slowly discharged and then recharged) to keep them in top condition. New batteries may need to be exercised before they will be capable of their full rating.

If your batteries are not the sealed type, distilled water should be added to them whenever needed. The electrolyte should cover the plates by about 1/2", allowing a small air space at the top. Do not fill the cells up to the filler cap as this could cause the battery to sputter out electrolyte when it is being charged. Only distilled water should be used never plain tap water. Tap water contains chemicals and elements that can alter the properties of the electrolyte, including specific gravity. Some chemicals may also create an insulating coating on the battery plates which will retard current flow.

The rate that water is lost by the battery is dependent on several factors; battery condition, ambient temperature,



battery use, charge voltage, etc. It is normal for batteries which are not maintenance-free to require topping off about once a month.

A battery's state of charge may be monitored by checking the specific gravity or by open circuit voltage. You may use the following table to evaluate the condition of your batteries:

Specific Gravity Measured by Hydrometer	Open Circuit Voltage		State of Discharge @ 80° F
	12 Volt System	24 Volt System	
1.265	12.6 or more	25.2 or more	Fully Discharged
1.225	12.4	24.8	25% Discharged
1.190	12.2	24.4	50% Discharged
1.155	12.0	24.0	75% Discharged
1.120	11.7 or less	23.4 or less	100% Discharged

* **Note:** Wait at least 5 minutes after charging or discharging before checking specific gravity or open circuit voltage. The battery's voltage needs to stabilize in order to get an accurate reading.

Troubleshooting Your Battery System

If your battery will not accept or hold a charge, one of the following conditions may exist:

1. A BAD BATTERY. You may have a battery with an open or shorted cell, a battery without any "life" left. Check by charging the battery until all cells have a specific gravity of 1.225 or greater at 80° F. If you are unable to obtain 1.225 in each cell, replace the battery. For maintenance-free or gel-cell batteries consult the manufacturer.

2. A BAD BATTERY CHARGER. If the battery open circuit voltage is low and/or the hydrometer indicates your batteries are low, the battery charger should be providing current to the batteries. If it is not, check AC input and check to see that you have charging voltage on the output with no battery attached. Note: You will not get an accurate voltage reading on the output of the charger with no batteries attached. This is checked merely to ensure that you do not have an open circuit on the output.

The battery charger has a thermal cutout switch to turn the charger off if it is overheating. If you suspect this is the case, refer to the information regarding charger location in the Installation section and cooling fans in the Application Notes section.

3. ELECTRICAL LEAKAGE. You may have a previously unsuspected source of current drain from the battery. To check for a leakage of this sort, disconnect the battery ground cable and connect an ammeter between the negative battery post and ground. If you have a reading over .1 amp, there is a source of current drain from the batteries which must be located and removed.

IX) REFERENCE APPENDIX

- For more information about boat wiring to conform to US Coast Guard regulations, write: Superintendent of Documents and Request: 33 CFR 183 Subpart I.
- For more information about American Boat and Yacht Council recommendations for boat wiring, write to: American Boat and Yacht Council
3069 Soloman's Island Road
Edgewater, MD 21037
Request: Standards and Recommended Practices for Small Craft.
AC & DC systems: Section E-11
A-31: Battery Charging Devices
- For additional installation instructions, refer to: ANSI NFPA 302



XI) Unit Dimensional Drawing

