

- 10. FOR SPECIFIC INFORMATION CONTACT SALES.
- 9. COMPLETE ASSEMBLY WEIGHT W/ DECK RING, 36.9LBS/ 16.7K.
- 8. DOGGING PRESSURE FULLY ADJUSTABLE.
- 7. HANDLE POSITION TOPSIDE INDICATES WHETHER DOGGING MECHANISM IS IN OPEN OR CLOSED POSITION.
- 6. ALUMINUM ALLOY MECHANISM SHOWN.
- 5. FLUSH, WATERTIGHT CONSTRUCTION.
- 4. INTEGRAL TOPSIDE "T" HANDLE STANDARD, OTHER TOPSIDE ACTUATION AVAILABLE.
- 3. CAST ALUMINUM ALLOY FLANGE, FLANGE CAN BE DRILLED FOR BOLTED INSTALLATIONS OR WELDED TO ALUMINUM.
- 2. QUICK-ACTING, MECHANISM ENGAGES OR DISENGAGES IN QUARTER-TURN OF CENTER SPINDLE.
- 1. 19.8"/ 502MM DIAMETER CLEAR OPENING, ALL DIMENSIONS SHOWN SUBJECT TO CASTING VARIATION AND ARE REFERENCE ONLY.

NOTES: UNLESS OTHERWISE SPECIFIED.

CUSTOMER APPROVAL
 Signature: _____
 Date: _____

IMPORTANT! THIS DRAWING SUPERSEDES ALL OTHER DOCUMENTS. By signing this approval you accept and agree that the dimensions and details shown are correct and properly fit your application, regardless of any differences between this drawing and any contract specifications. Should you see any errors in the drawing, or have any questions, please contact your Freeman Marine sales engineer for clarification.

SPECIFICATIONS SUBJECT TO CHANGE WITHOUT NOTICE.		
PROJECTION		
UNLESS OTHERWISE SPECIFIED DIMENSIONS ARE IN INCHES. TOLERANCES FOR ROUGH AND CLEAR OPENINGS: .125 INCH. ALL OTHERS ARE: .X .XX .XXX ANGLES ±.1 ±.03 ±.010 ±2°		
DO NOT SCALE DRAWING		
REV.	DESCRIPTION:	DATE: DRAWN
-	INITIAL RELEASE	03 SEPT 08 SAS
A	UPDATE GEN NOTES AND B.O.M.	07JUL11 PPC

FREEMAN MARINE EQUIPMENT, INC.
 28336 HUNTER CREEK ROAD
 GOLD BEACH, OR 97444 U.S.A.
 PHONE: 541-247-7078 FAX: 541-247-2114
 www.freemanmarine.com

CONFIDENTIAL PROPERTY OF FREEMAN MARINE EQUIPMENT, INC. UNLESS OTHERWISE SPECIFIED OR OTHERWISE INDICATED, ALL RIGHTS RESERVED. THIS DOCUMENT IS THE PROPERTY OF FREEMAN MARINE EQUIPMENT, INC. AND SHALL BE RETURNED TO THE COMPANY UPON REQUEST.

CLIENT: **FREEMAN MARINE**

TITLE: **HATCH: 20, AL COVER, AL RING**

SIZE	CAGE CODE	DRAWING NUMBER	REV.
D	64747	2406-0002	A
SCALE: 1:2.5	CALC.WT.	ACT. WT.	SHEET 1 OF 3

DRAWN: S SNYDER DATE: 03 SEPT 08
 CHECKED: G. MACEACHERN DATE: 07JUL11
 ENGR: DATE:
 DESIGN ACTIVITY: DATE:
 CONTRACT NO.:

8 7 6 5 4 3 2 1

D

C

B

A

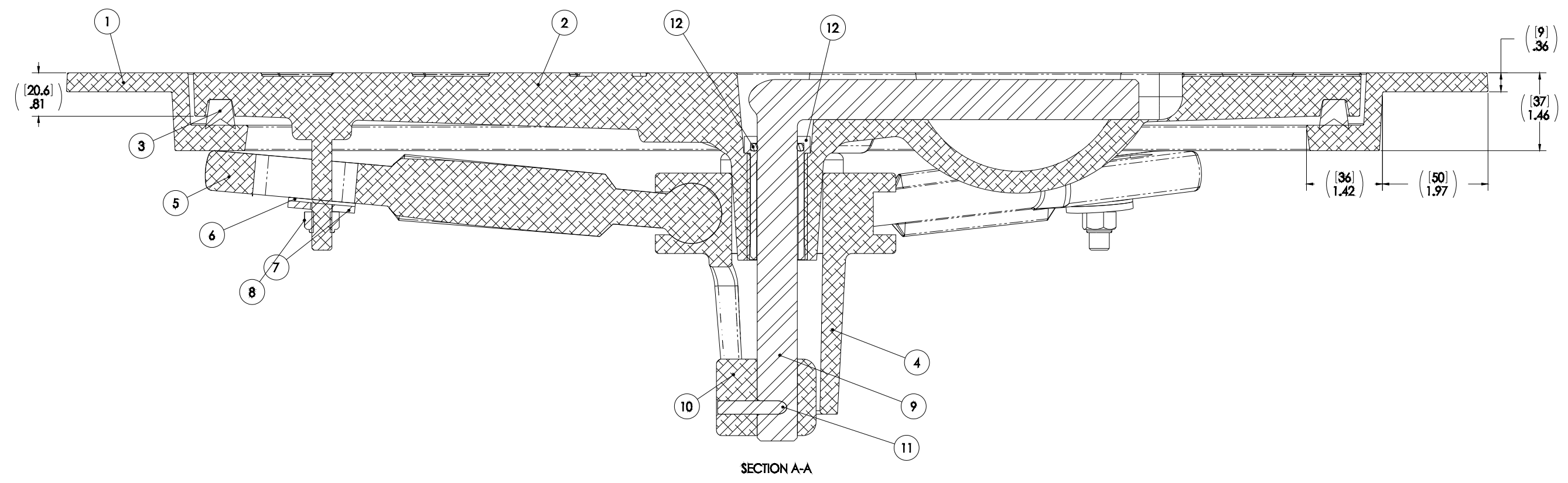

SECTION A-A

ITEM NO.	QTY.	PART NUMBER	DESCRIPTION	MATERIAL
12	1	0031-2058	BUSHING ASSY, W/O-RING, NO SLEEVE	ACETRON/RUBBER
11	1	0411-2004	PIN KNURLED .25 X 2.25IN SS 316	SS 316/316L
10	1	0112-2001	ACTUATOR, AL	ALUMINUM, 535
9	1	0021-2005	HANDLE, S/S, ROUND BAR	STAINLESS STEEL, 316
8	4	0411-2032	NUT .375IN-16 SS 316 NYLOCK	SS 316/316L
7	4	0411-2033	WASHER .406 X 1.25 X .125IN SS 316	SS 316/316L
6	4	0413-2005	WASHER .406 X 1.250 X .062 NYLON	NYLON
5	4	0211-2008	DOG, LOCKING ARM 20, AL	ALUMINUM, 535.2-F
4	1	0011-2002	HUB, AL, 4 HOLE	ALUMINUM, 535.2-F
3	1	9801-2007	GASKET:	NEOPRENE
2	1	2406-3001	COVER: 20 ALUM, FINISHED CASTING	ALUMINUM, A356.0-F
1	1	2406-1002	RING:20 ALUM	ALUMINUM, A356.0-F

REV.	DESCRIPTION	DATE	DRAWN
-	INITIAL RELEASE	03 SEPT 08	SHS
A	UPDATE GEN NOTES AND B.O.M.	07JUL11	PPC

SPECIFICATIONS SUBJECT TO CHANGE WITHOUT NOTICE.

PROJECTION

UNLESS OTHERWISE SPECIFIED DIMENSIONS ARE IN INCHES. TOLERANCES FOR ROUGH AND CLEAR OPENINGS: .125 INCH. ALL OTHERS ARE:
 .X .XX .XXX ANGLES
 ±.1 ±.03 ±.010 ±2°

DO NOT SCALE DRAWING

FREEMAN MARINE EQUIPMENT, INC.
 28336 HUNTER CREEK ROAD
 GOLD BEACH, OR 97444 U.S.A.
 PHONE: 541-247-7078 FAX: 541-247-2114
 www.freemanmarine.com

CLIENT: FREEMAN MARINE

TITLE: HATCH: 20, AL COVER, AL RING

SIZE: D CAGE CODE: 64747 DRAWING NUMBER: 2406-0002 REV. A

SCALE: 1:1 CALC. WT. ACT. WT. SHEET 2 OF 3

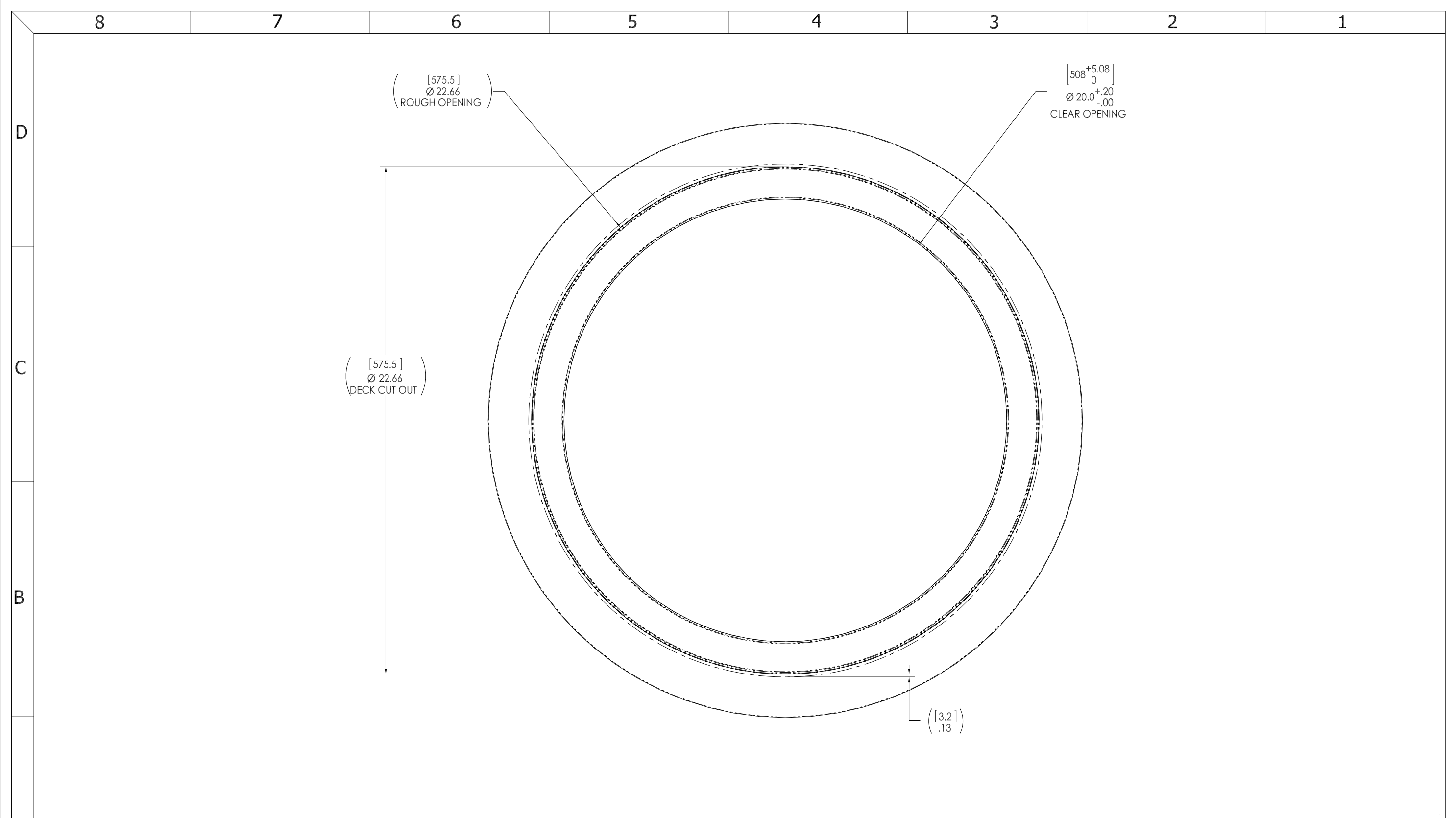

- 3. FINISH: 125 RMS MAX.
- 2. BREAK SHARP EDGES AND DEBURR.
- 1. MATERIAL: ALUMINUM

NOTES: UNLESS OTHERWISE SPECIFIED.

CUSTOMER APPROVAL

Signature: _____

Date: _____

IMPORTANT! THIS DRAWING SUPERSEDES ALL OTHER DOCUMENTS. By signing this approval you accept and agree that the dimensions and details shown are correct and properly fit your application, regardless of any differences between this drawing and any contract specifications. Should you see any errors in the drawing, or have any questions, please contact your Freeman Marine sales engineer for clarification.

REV.	DESCRIPTION	DATE	DRAWN
-	INITIAL RELEASE	03 SEPT 08	SAS
A	UPDATE GEN NOTES AND B.O.M.	07JUL11	PPC

SPECIFICATIONS SUBJECT TO CHANGE WITHOUT NOTICE.

PROJECTION

UNLESS OTHERWISE SPECIFIED DIMENSIONS ARE IN INCHES. TOLERANCES FOR ROUGH AND CLEAR OPENINGS: .125 INCH. ALL OTHERS ARE:

.X	.XX	.XXX	ANGLES
±.1	±.03	±.010	±2°

DO NOT SCALE DRAWING

		28336 HUNTER CREEK ROAD GOLD BEACH, OR 97444 U.S.A. PHONE: 541-247-7078 FAX: 541-247-2114 www.freemanmarine.com	
		CLIENT:	FREEMAN MARINE
<small>CONFIDENTIAL PROPERTY OF FREEMAN MARINE EQUIPMENT, INC. UNLESS OTHERWISE SPECIFIED. ALL RIGHTS RESERVED 2012. FREEMAN MARINE EQUIPMENT, INC.</small>		TITLE: HATCH: 20, AL COVER, AL RING	
DRAWN: S SNYDER CHECKED: G. MACEACHERN ENGR: DESIGN ACTIVITY: CONTRACT NO.:	DATE: 03 SEPT 08 DATE: 07JUL11 DATE:	SIZE: D CAGE CODE: 64747 SCALE: 1:2	DRAWING NUMBER: 2406-0002 ACT. WT.: SHEET 3 OF 3