

interceptors

PREMIUM BOAT CONTROL WITH X, H, HA, HE-SERIES

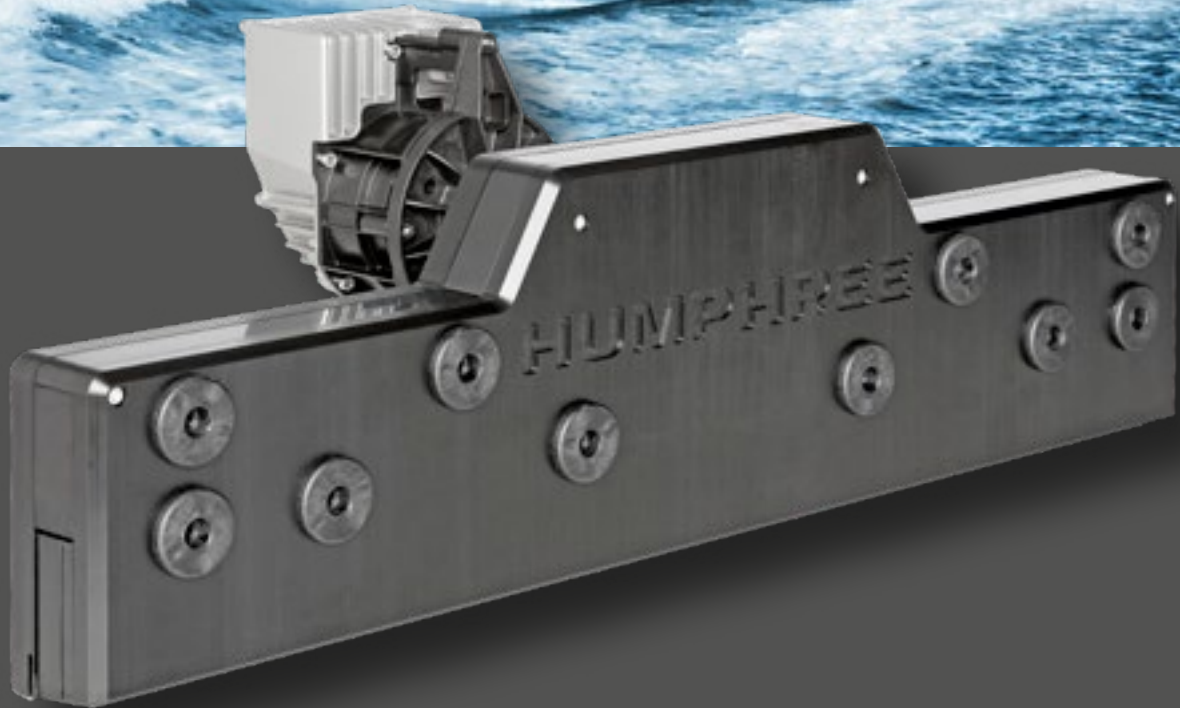

HUMPHREE®

Trim and stabilisation systems

automatic interceptor systems

With Humphree ACTIVE stabilisation, everyone on board will feel as safe and steady as on dry land. This system lowers roll and slamming by up to 50% and it feels like even more. Your boat ride will be an entirely new experience.

control systems

Boat control systems for all needs

The fine-tuned control options provide optimum comfort, safety and performance regardless of whether the captain is a professional or a less experienced operator.

Auto Trim functionality is included standard on all our interceptor systems to ensure the lowest fuel consumption, the best comfort and less impact on our environment.

SEPARATE FUNCTIONS OR FULL DYNAMICS PACKAGE

- | | |
|----------------------------|----------|
| • Automatic Trim Control | Included |
| • Automatic List Control | Option |
| • Coordinated Turn Control | Option |

PACKAGES

- ACTIVE Stabilisation:
Auto Trim, Auto List & Stabilisation
- ACTIVE+ Stabilisation:
Auto Trim, Auto List, Coordinated Turn & Stabilisation



Automatic control is the future

With new technology both trim and list can be controlled automatically. Humphree calls this functionality Auto Trim Control and Auto List Control. Other manufacturers may have other names and all will claim to have "automatic control". It is easy to claim to have "auto" but the big challenge is to deliver a safe and reliable function that will handle all situations at sea, especially when the sea conditions are getting worse. The reaction time for generating lift force is paramount for a well-functioning true automatic control that doesn't create surprises or even result in unsafe situations. For improved behavior during turns, Humphree offers the Coordinated Turn Control. The function coordinates the rudder movement with the interceptors to create a heel angle during the turn that is highly comfortable! The turning radius can also be significantly reduced with the Coordinated Turn Control.

The interceptor's main function is to create a lift force in order to reduce the boats wave resistance giving improved performance. The same function can be generated by a traditional trim tab, however an interceptor is more efficient. With reduced wave resistance, the speed is increased and fuel consumption is reduced. The lift force generated is also used to counteract undesirable boat list (heel) that may be the result of uneven load or cross winds causing the boat to list. The key to achieve good control of the boat dynamics is how fast the lift forces can be generated on the hull. Interceptor blades can extend relatively easy, allowing them to move very fast if a powerful servo motor is involved. This is why we use ultra-fast servo actuators moving 50mm(2") in less than 0.7 seconds!

POWERFUL 50MM STROKE

X-series

For boats from 25 to 60 feet.

The X-Series delivers the same reliability and superior performance as the other Humphree interceptors but the X-Series range is limited to five standard sizes: X300, X450, X600, X750 and X900. The X300 and X450 are also an excellent choice for high performance RIBs. The X-Series features the same control system, ultra-fast servo actuators and control panel. For boats with stern drive a special "13 degree" mounting plate is available for a perfect fit.



- Available sizes: 300 – 900mm
- Stroke length: 50mm
- Mounting plates: 20mm composite or 25mm aluminium
- Transom thickness: Short shaft kit (standard), <80mm transom thickness.
- Long shaft kit (option), <140mm transom thickness
- Bureau Veritas approved through-hull design

50mm (2") blade stroke

The powerful 50mm (2") stroke is needed for superior control of dynamic hull motions. To control boat list effectively it is essential to position the lift force as far out from the keel as possible creating a large righting arm. For this reason Humphree use minimum 50mm stroke on our interceptors. The interceptor force must quickly build up as close to the chine as possible, providing fast response and keeping the boat at even keel in a safe and comfortable manner.

When placing lift force over a wide area of the transom, much more lift force needs to be generated to create the same counteracting boat movement and this will typically cause undesired trimming of the boat generating a bow down condition causing a bad behaving boat. X-Series full 50mm blade movement ensure that the lift force can be positioned where it should be positioned – close to the chines! In a boat larger than 55ft a wider part of the transom can be used as the trimming effect drops with the size of the hull.

POWERFUL 50MM STROKE LENGTH

H-Series

H-Series are available from 350 – 1500mm in width. H-Series characterizes a customizable interceptor. We can custom shape it for the hull and a perfect fit at the shine or make it follow the radius of the propeller tunnels, no matter how the hull has been designed there is always a solution.

Available sizes: 350 – 1500mm

Stroke length: 50mm

Mounting plates:
20mm composite or 25mm aluminium

Transom thickness:
Short shaft kit (standard)
<80mm transom thickness.

Long shaft kit (option),
<140mm transom thickness

BUREAU VERITAS APPROVED THROUGH-HULL DESIGN

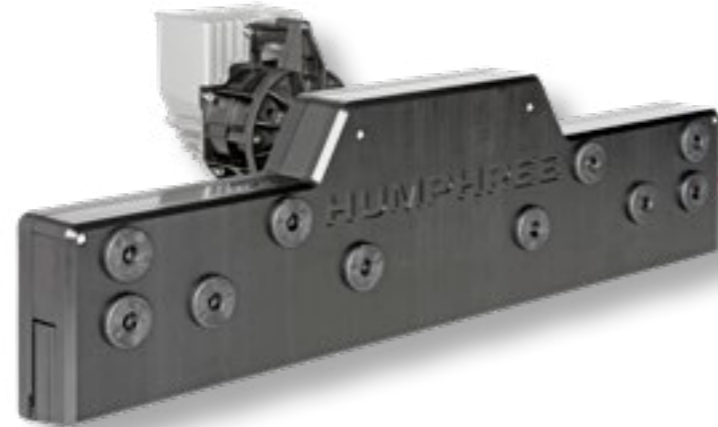

POWERFUL 75MM STROKE LENGTH

HE-Series

FOR
LARGE
VESSELS

The HE-Series interceptors are designed for more effect with a smaller interceptor. With their powerful 75mm stroke length they will add 50% more blade area than the standard 50mm interceptors. The HE-interceptor comes in sizes 750 – 1500mm and can be custom shaped for a perfect fit.

Available sizes: 750 – 1500mm

Stroke length: 75mm

Mounting plates:
20mm composite or 30mm aluminium

Transom thickness:
Short shaft kit (standard), <80mm transom thickness.

BUREAU VERITAS APPROVED THROUGH-HULL DESIGN



Also available as asymmetric (HAE series)

POWERFUL 50MM STROKE LENGTH

HA-Series

HA-Series is our line of interceptors with an asymmetric placed servo unit. This interceptor can be used when it has to fit under a water jet or if preferred area of the transom is limited or when the inner structure on the inside of the transom does not allow for a centre placed servo. The HA-interceptor comes in sizes 500 – 1100mm and can be custom shaped for a perfect fit.

Available sizes: HA500 – HA1100 (50mm stroke, asymmetric)

Available sizes: 500 – 1100mm

Stroke length: 50mm

Mounting plates:
20mm composite or 30mm aluminium

Transom thickness:
Short shaft kit (standard),
<80mm transom thickness.

Long shaft kit (option), <140mm transom thickness

BUREAU VERITAS APPROVED THROUGH-HULL DESIGN



Custom shape

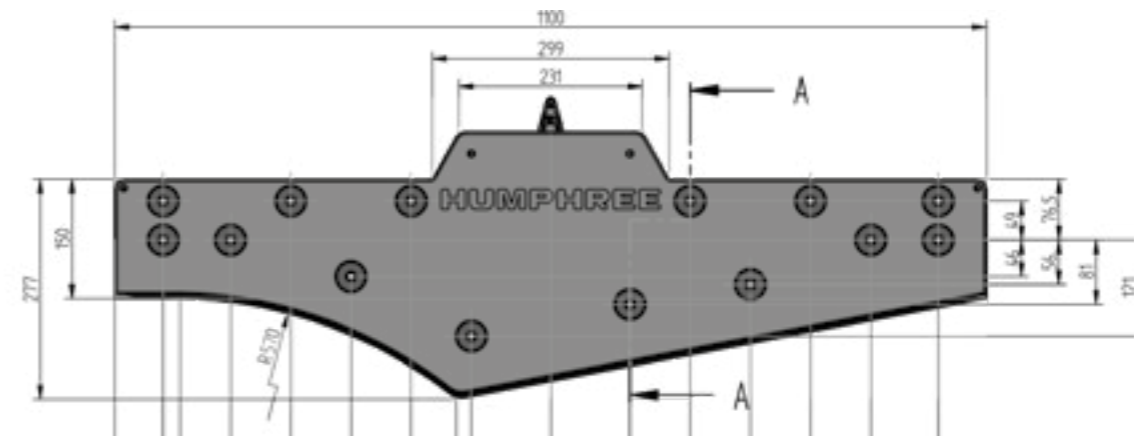

BUREAU VERITAS APPROVED THROUGH-HULL DESIGN

For H, HA, HE, HAE-series

It is common to customize the interceptors according to the boat shape. Ideal for water jet applications or like the installation shown in the picture.



Humphree System Arrangement

HUMPHREE INTERCEPTORS DIMENSIONS

GENERAL SYSTEM ARRANGEMENT - MONO HULL

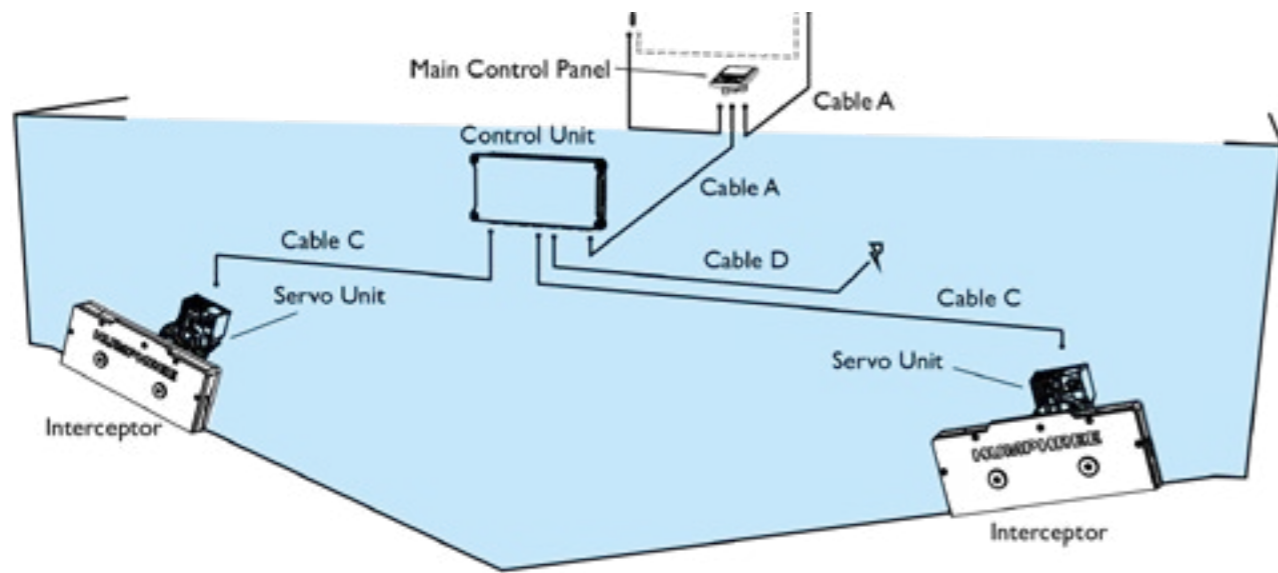

Type	W x H x T (mm)	Weight (kg)	Blade stroke, D (mm)
Standard Interceptor	350-1500 x 210 x 60	from 5 - 17	50
Extended Interceptor	750-1500 x 285 x 70	from 17 - 31	75
Servo Unit	124 x 159 x 121	2	-
Control Unit	343 x 160 x 58	1	-
Control Panel	102 x 132 x 14/52	0.2	-

Type	Length (m)	Description
Cable A	10, 15, 20, 25, 30, 40, 50	From Control Unit to Control Panel and between Control Panels
Cable B	5, 10, 20	Between Control Units
Cable C	4, 8	From Servo Unit to Control Unit. 8m cable applies to 24V DC only
Cable D	3.5	From Control Unit to power supply

GENERAL SYSTEM ARRANGEMENT - CATAMARAN

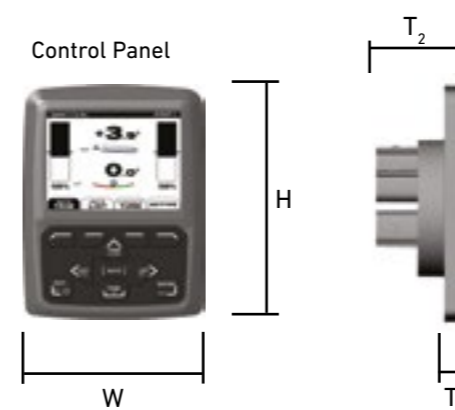
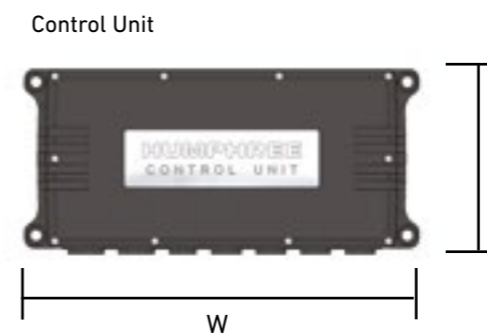
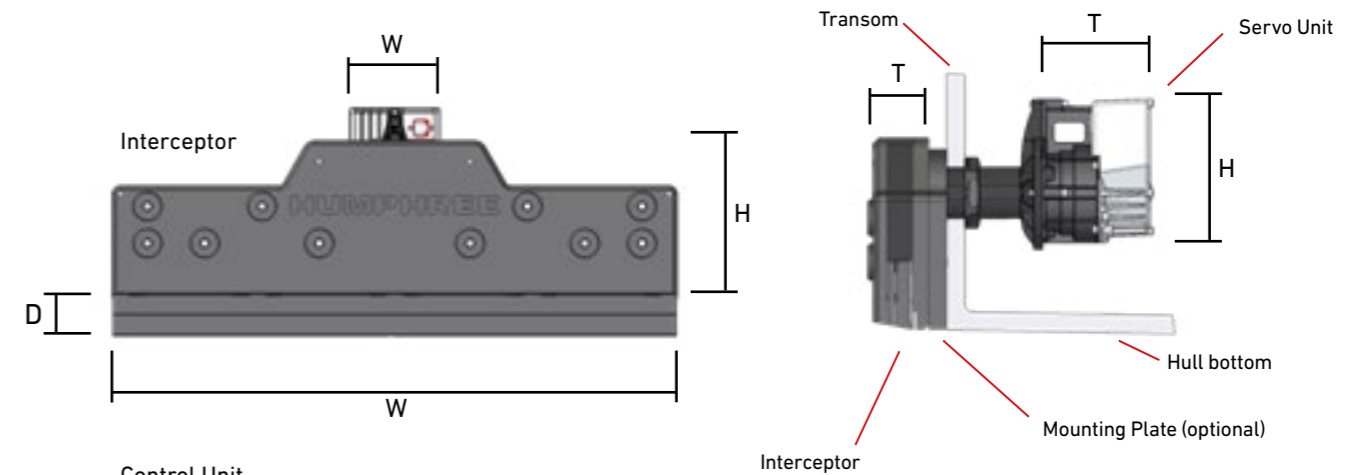
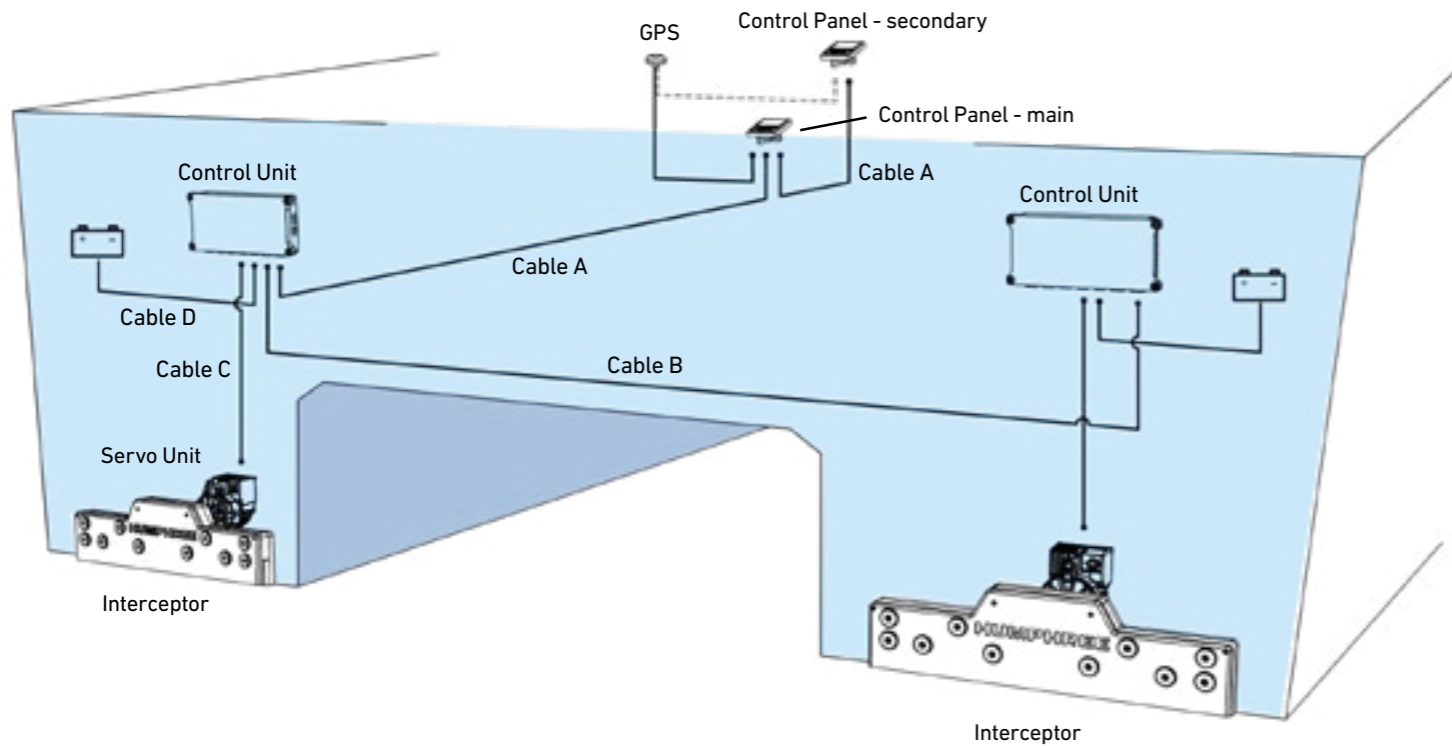

Mounting plates

For best possible interceptor mounting, a Mounting Plate is fixed to the hull with through hull bolts. It brings the best possible mounting surface and it facilitates service action and maintenance. The plate is prepared from factory with stainless steel inserts for Interceptor mounting to the plate.

Bolts for fixing Interceptor to the Mounting Plate are included in the delivery.

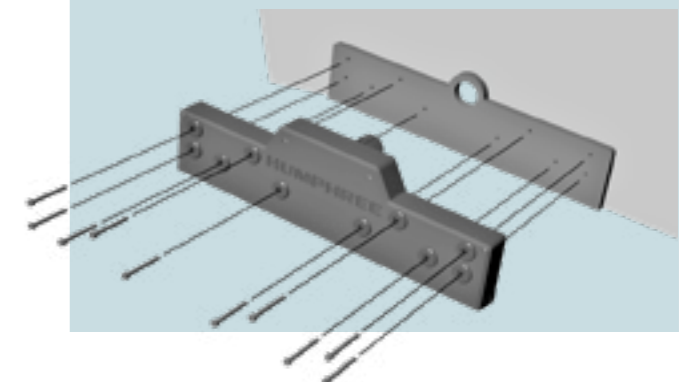

Recommended interceptor sizes for semi-planing and planing boats

Humphree recommends using the column "Recommended". Where space does not permit this size please refer to the description below regarding the limitations of the options. In some cases, the larger interceptor is not required if the boat has a natural "Low" trim mode, which means that a smaller size can be selected.

Boat Size	Recommended	Trim & List	List
23-27 ft	X300	X300	X300
28-33 ft	X450	X300	X300
34-39 ft	X600	X450	X300
40-44 ft	X750	X600	X450
45-49 ft	X750	X600	X450
50-54 ft	X900 or HE750	X750	X450
55-59 ft	H1000 or HE750	X750	X600
60-64 ft	H1200 or HE800	X900 or HE750	X600
65-69 ft	H1300 or HE900	H1050 or HE800	X750
70-74 ft	H1500 or HE1000	H1100 or HE850	X750

The premium choice

Humphree equipment is designed and manufactured to deliver world-class quality and reliability. Customer support and spare parts are available wherever and whenever needed, through our Head Office in Sweden or via our expanding network of local representatives around the world.

www.humphree.com

FOR YOUR CLOSEST HUMPHREE REPRESENTATIVE

Humphree AB • Grimboåsen 16 • 417 49 Göteborg SWEDEN
+46 31 744 35 77 • humphree@humphree.com