



MASS COMBI ULTRA

12/3000-150, 24/3500-100, 48/3500-50

MULTI PURPOSE CHARGER INVERTER



USER AND INSTALLATION MANUAL

10000006554/10

To download this manual in other languages, please
visit our website: www.mastervolt.com

OVERVIEW MASS COMBI ULTRA

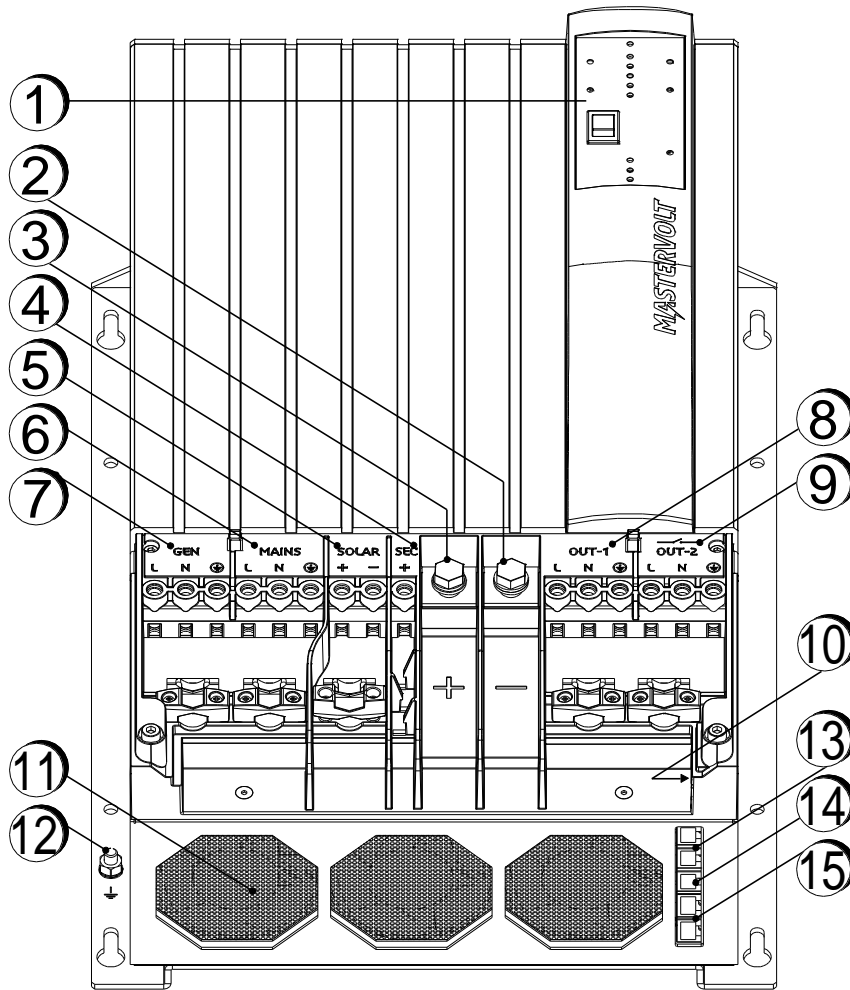

Figure 0-1: Overview of the Mass Combi Ultra

| | | |
|---------------------------------------|--|----------------------------------|
| 1. Display with front switch | 6. Mains AC input terminal ("MAINS") | 11. Fan (3x) |
| 2. Main battery negative | 7. Generator AC input terminal ("GEN") | 12. Ground stud |
| 3. Main battery positive | 8. AC output 1 ("OUT-1") | 13. Sync connector (2x) |
| 4. Secondary battery positive ("SEC") | 9. AC output 2 ("OUT-2") (switched) | 14. Temperature sensor connector |
| 5. Solar DC terminal ("SOLAR")* | 10. DIP switch units (2x8) | 15. MasterBus connector (2x) |

* Models 12/3000-150 and 24/3500-100 only

TABLE OF CONTENTS:

| | | | |
|---|-----------|--|--|
| OVERVIEW MASS COMBI ULTRA | 2 | | |
| 1 GENERAL INFORMATION | 4 | | |
| 1.1 Product description | 4 | | |
| 1.2 Use of this manual | 4 | | |
| 1.3 Validity of this manual | 4 | | |
| 1.4 Disclaimer | 4 | | |
| 1.5 Scope of warranty | 4 | | |
| 1.6 Liability | 4 | | |
| 1.7 Changes to the Mass Combi Ultra | 4 | | |
| 1.8 Identification label | 4 | | |
| 1.9 Correct disposal of this product | 4 | | |
| 2 SAFETY GUIDELINES AND WARNINGS..... | 5 | | |
| 2.1 Warnings and symbols | 5 | | |
| 2.2 Use for intended purpose | 5 | | |
| 2.3 Organizational measures | 5 | | |
| 2.4 Warning of special dangers | 5 | | |
| 2.5 General safety and installation precautions | 5 | | |
| 2.6 Warning regarding life support applications | 6 | | |
| 2.7 Warning regarding the use of batteries | 6 | | |
| 3 HOW IT WORKS | 7 | | |
| 3.1 Principle | 7 | | |
| 3.1.1 User interface (1)..... | 7 | | |
| 3.1.2 AC transfer switch (2)..... | 7 | | |
| 3.1.3 Inverter/ Main charger (3)..... | 7 | | |
| 3.1.4 Solar charger (4)* | 7 | | |
| 3.1.5 Secondary charger (5)..... | 7 | | |
| 3.2 Battery charger | 7 | | |
| 3.2.1 3-step+ charge system..... | 7 | | |
| 3.2.2 Temperature compensated charging..... | 8 | | |
| 3.2.3 Connection of a secondary battery..... | 8 | | |
| 3.3 Inverter | 8 | | |
| 3.3.1 General | 8 | | |
| 3.3.2 Energy saving mode (selectable)..... | 8 | | |
| 3.4 Operation modes | 8 | | |
| 3.4.1 Inverting mode..... | 9 | | |
| 3.4.2 Charging mode..... | 9 | | |
| 3.4.3 Output 1 and 2..... | 9 | | |
| 3.4.4 Power sharing mode | 10 | | |
| 3.4.5 Gen-/Mains support..... | 10 | | |
| 3.4.6 Solar charging | 11 | | |
| 3.4.7 Secondary charging mode | 11 | | |
| 3.4.8 Silent mode | 11 | | |
| 4 OPERATION..... | 12 | | |
| 4.1 LED indicators | 12 | | |
| 4.1.1 Solar charging LED* | 12 | | |
| 4.1.2 Generator input LED | 12 | | |
| 4.1.3 Mains input LED | 12 | | |
| 4.1.4 Power bar LEDs..... | 12 | | |
| 4.1.5 AC Output-1 LED | 12 | | |
| 4.1.6 AC Output-2 LED | 12 | | |
| 4.1.7 Charge bar LEDs | 12 | | |
| 4.1.8 Secondary charging LED | 12 | | |
| 4.1.9 Main switch | 12 | | |
| 4.2 Protections | 13 | | |
| 4.2.1 Output overload or short circuit | 13 | | |
| 4.2.2 Overheating | 13 | | |
| 4.2.3 Under and over voltage..... | 13 | | |
| 4.2.4 Dynamic DC input window | 13 | | |
| 4.3 Operation policies..... | 13 | | |
| 4.3.1 AC input policy | 13 | | |
| 4.3.2 AC Output-2 policy | 13 | | |
| 4.3.3 Secondary charging policy | 14 | | |
| 4.4 Maintenance..... | 14 | | |
| 4.5 Daily use, MasterBus monitoring..... | 14 | | |
| 5 INSTALLATION | 15 | | |
| 5.1 Unpacking | 15 | | |
| 5.2 Environment | 15 | | |
| 5.3 Wiring | 15 | | |
| 5.3.1 AC-wiring | 15 | | |
| 5.3.2 DC wiring | 16 | | |
| 5.3.3 AC safety grounding | 16 | | |
| 5.4 Things you need..... | 16 | | |
| 5.5 Removal of the front lid..... | 16 | | |
| 5.6 Mounting the cabinet to a surface | 17 | | |
| 5.7 Wiring instructions | 17 | | |
| 5.8 Installation overview | 18 | | |
| 5.9 Setting up a MasterBus network..... | 19 | | |
| 5.10 How to set up a MasterBus network..... | 19 | | |
| 6 CONFIGURATION..... | 20 | | |
| 6.1 Configuration via DIP-switches..... | 20 | | |
| 6.1.1 Ground relay | 20 | | |
| 6.2 MasterBus configuration..... | 21 | | |
| 6.2.1 MasterBus alarms | 23 | | |
| 6.2.2 List of event sources | 23 | | |
| 6.2.3 List of event commands | 24 | | |
| 7 COMMISSIONING, DECOMMISSIONING | 25 | | |
| 7.1 Commissioning..... | 25 | | |
| 7.2 Decommissioning | 25 | | |
| 7.3 Trouble shooting..... | 25 | | |
| 7.3.1 Trouble shooting table | 26 | | |
| 8 TECHNICAL DATA | 27 | | |
| 8.1 Specifications | 27 | | |
| 8.2 Dimensions..... | 30 | | |

1 GENERAL INFORMATION

1.1 Product description

The Mass Combi Ultra is a multifunctional charger inverter. It passes through power from an external AC source (e.g. a generator or shore power connection) to your AC loads and charges your main batteries.

In addition, it can charge a secondary battery bank with a dedicated charge algorithm. Solar modules can be connected for additional power to charge both battery banks.

1.2 Use of this manual

This manual serves as a guideline for the safe and effective use and installation of the Mass Combi Ultra, also called Combi Ultra further in this manual:

- For the installer this manual gives directions for the installation, operation and commissioning.
- For the end user, this manual gives directions for the operation, maintenance and possible correction of minor malfunctions.
- Every person who works with the device should be familiar with the contents of this manual and must carefully follow the instructions contained herein.
- Store the manual in an accessible place.

1.3 Validity of this manual

This manual is valid for the following models:

| Part no | Model |
|----------|------------------------------|
| 38013000 | Mass Combi Ultra 12/3000-150 |
| 38023500 | Mass Combi Ultra 24/3500-100 |
| 38043500 | Mass Combi Ultra 48/3500-50 |

All the specifications, provisions and instructions contained in this manual apply solely to the Mastervolt-delivered standard version of a single Mass Combi Ultra.

1.4 Disclaimer

Our products are subject to continual development and improvement. Therefore, additions or modifications to the products may cause changes to the technical data and functional specifications. No rights can be derived from this document. Please consult our most current Terms & Conditions of Sale.

1.5 Scope of warranty

Mastervolt assures the product warranty of the Mass Combi Ultra during two years after purchase, on the condition that all instructions and warnings given in this manual are taken into account during installation and operation.

Among other things, this means that installation is carried out by a qualified electrician, that installation and maintenance are executed according to the stated instructions and correct working sequence, and that no changes or repairs may have been performed on the Mass Combi Ultra other than by Mastervolt. The warranty is

limited to the costs of repair and/or replacement of the product by Mastervolt only.

Costs for installation labour, shipping of the defective parts and indirect damage are not covered by this warranty. For making an appeal on warranty you can contact your supplier directly, stating your complaint, application, date of purchase and part number / serial number.

1.6 Liability

Mastervolt accepts no liability for:

- consequential damage due to use of the Mass Combi Ultra;
- possible errors in the manuals and the results thereof.
- use that is inconsistent with the purpose of the product.

1.7 Changes to the Mass Combi Ultra

Changes to the Mass Combi Ultra may be carried out only after obtaining the written permission of Mastervolt. This is not applicable for DIP-switches which are used for user settings.

1.8 Identification label



Figure 1-1: Example of an identification label

The identification label is positioned at the right side of the Mass Combi Ultra, see figure 1-1.



CAUTION!

Never remove the identification label.

1.9 Correct disposal of this product



This product is designed and manufactured with high quality materials and components, which can be recycled and reused.

Please be informed about the local separate collection system for electrical and electronic products.

Please act according to your local rules and do not dispose of your old products with your normal household waste. The correct disposal of your old product will help prevent potential negative consequences to the environment and human health.

2 SAFETY GUIDELINES AND WARNINGS

2.1 Warnings and symbols

Safety instructions and warnings are marked in this manual and on the product by the following pictograms:



A procedure, circumstance, etc. which deserves extra attention.



CAUTION!

Special information, commands and prohibitions in order to prevent damage.



WARNING

A WARNING refers to possible injury to the user or installer or significant material damage to the Mass Combi Ultra if the installer / user does not (carefully) follow the stated procedures.



Read this manual before installation and use



This product complies with the EC directives and standards.

IP23

Degree of protection: IP23. The product is protected against touch by fingers and water spray < 60 degrees from vertical.



Safety class 1. This product must be provided with an equipment grounding conductor to the AC-output ground terminal

2.2 Use for intended purpose

- 1 The Mass Combi Ultra is constructed as per the applicable safety-technical guidelines.
- 2 Use the Mass Combi Ultra only:
 - for the charging of batteries and the supply of loads attached to these batteries, in permanent systems;
 - for the conversion of battery DC voltage to AC voltage;
 - when connected to a dedicated double pole circuit breaker and RCD;
 - with fuses, protecting the Mass Combi Ultra AC and DC wiring;
 - in a technically correct condition;
 - in a closed, well-ventilated room, protected against rain, moist, dust and condensation;
 - after observing the instructions in the user manual.



WARNING

NEVER connect shore power to the generator input. This may result in an electric shock!



WARNING

Never use the Mass Combi Ultra in situations where there is danger of gas or dust explosion or potentially flammable products!

- 3 Use of the Mass Combi Ultra other than mentioned in point 2 is considered to be inconsistent with the intended purpose. Mastervolt does not hold itself liable for any damage resulting from the above.

2.3 Organizational measures

The user must always:

- have access to the user manual;
- be familiar with the contents of this manual. This applies in particular to chapter 2, Safety Guidelines and Measures.

2.4 Warning of special dangers

- 1 If the Mass Combi Ultra is switched off during maintenance and/or repair activities, it should be secured against unexpected and unintentional switching on:
 - Remove the AC supply.
 - Remove the connection to the batteries.
 - Be sure that others cannot reverse the measures taken.
- 2 If maintenance and repairs are required, use only original spare parts.

2.5 General safety and installation precautions

- Do not expose the Mass Combi Ultra to rain, snow, spray, moisture, excessive pollution and condensing circumstances. To reduce risk of fire hazard, do not cover or obstruct the ventilation openings. Do not install the Combi Ultra in a non-ventilated area, overheating results.
- The Mass Combi Ultra must be provided with an equipment grounding conductor to the AC-input ground terminal. Grounding and all other wiring must comply with local rules and regulations.
- In case of fire, you must use a fire extinguisher which is appropriate for electrical equipment.
- Short circuiting or reversing polarity will lead to serious damage to batteries, Combi Ultra and wiring. Fuses between batteries and Combi Ultra cannot prevent damage caused by reversed polarity and warranty will be void.
- Protect all DC wiring with a proper fuse, according to the guidelines in this manual.
- Connection and protection must be done in accordance with local standards.
- Do not work on the Mass Combi Ultra or system if it is still connected to a power source. Only allow changes in your electrical system to be carried out by qualified electricians.

- Check the wiring and connections at least once a year. Defects such as loose connections, burnt cables etc. must be corrected immediately.
- Do not touch the equipment when wet or with clammy hands.
- Not only the batteries, but the Mass Combi Ultra as well can become a projectile if your vehicle is involved in an accident! Ensure adequate and secure mounting and always use suitable transportation handling equipment.
- Except for the connection compartment, see section 5.5, the cabinet of the Mass Combi Ultra must not be opened. There are no serviceable parts inside the cabinet. Only qualified, authorized and trained electricians are allowed to open the connection compartment.

2.6 Warning regarding life support applications

The Mass Combi Ultra products are not sold for applications in any medical equipment intended for use as a component of any life support system unless a specific written agreement pertaining to such intended use is executed between the manufacturer and Mastervolt. Such agreement will require the equipment manufacturer either to contract additional reliability testing of the Mass Combi Ultra parts and/or to commit to undertake such testing as a part of the manufacturing process. In addition, the manufacturer must agree to indemnify and not hold Mastervolt responsible for any claims arising from using Mass Combi Ultra parts for life support equipment.

2.7 Warning regarding the use of batteries

Excessive battery discharge and/or high charging voltages can cause serious damage to batteries. Do not exceed the recommended limits of your batteries. Avoid short circuiting batteries, as this may result in explosion and fire hazard. Installation of the batteries and adjustments of the Mass Combi Ultra should only be undertaken by authorised personnel!

3 HOW IT WORKS

The Mass Combi Ultra is a multifunctional charger inverter. It combines an inverter, a battery charger with secondary (small) charger, an AC transfer switch and a solar charger*.

3.1 Principle

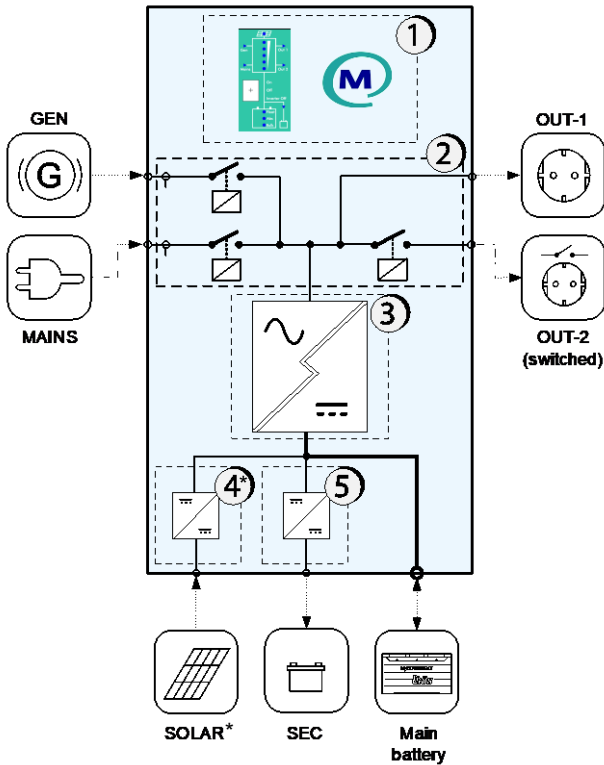

Figure 3-1: Working principle of the Mass Combi Ultra

3.1.1 User interface (1)

The Mass Combi Ultra user interface consists of a front switch with status LEDs and MasterBus communication.

3.1.2 AC transfer switch (2)

This part of the Mass Combi Ultra regulates the AC energy flow through the device. The generator (“GEN”) and mains (“MAINS”) input are switched, as is AC output 2 (“OUT-2”). All AC is connected to the inverter (3). If the MAINS plug is disconnected and the Generator is not running, the inverter takes over using battery power to provide AC power.

3.1.3 Inverter/ Main charger (3)

This part converts the AC power to DC for charging of the main battery and it inverts the DC power from the battery to supply AC to Output 1 and 2. (“OUT-1” and “OUT-2”).

3.1.4 Solar charger (4)*

The PV input (“SOLAR”) is meant for the connection of a PV-array. The PV-voltage is converted to the proper DC voltage for battery charging.

3.1.5 Secondary charger (5)

The secondary battery charger (“SEC”) is suitable for a secondary battery set or as power supply.

3.2 Battery charger

The built-in battery charger is electronically controlled. It is designed for optimal recharging of lead acid (flooded, gel, AGM) and Li-ion batteries. Battery charging via AC or Solar input is accomplished with Mastervolt’s 3-Step+ charging algorithm. With an external AC source connected, the Mass Combi Ultra charger also serves the functions of an AC to DC converter to supply DC loads which are connected to the batteries. Simple, automatic operation is enabled by the microprocessor that is the brain of the inverter/charger combination.

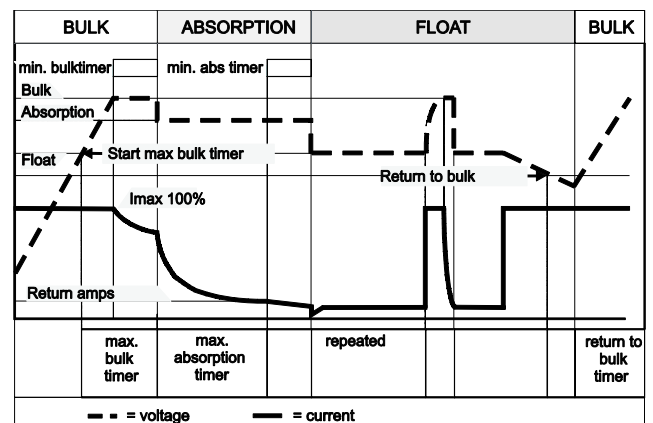

Figure 3-2: 3-step+ charge system

3.2.1 3-step+ charge system

See figure 3-2. The first step of the 3-step+ charge system is the BULK phase, in which the output current of the charger is 100 %, and the greater part of the battery capacity is charged rapidly. The current charges the batteries and gradually the voltage rises to the absorption voltage, refer to the specifications. The duration of this phase depends on the ratio of battery capacity to charger current, the loads connected and the degree to which the batteries were discharged to begin with.

The bulk phase is followed by the absorption phase. Absorption charging ends when the battery is completely full. Battery voltage remains constant throughout this stage and the charge current decreases during charging of the battery. With flooded batteries this stage lasts some four hours, with gel and AGM around three. Once the battery is 100 % full or when the maximum absorption timer has passed, the charger automatically switches over to the float phase.

* Models 12/3000-150 and 24/3500-100 only

During the float phase the Mass Combi Ultra switches to Float voltage, refer to the specifications, and stabilises this voltage to maintain the batteries in an optimum condition. Connected DC-loads are powered directly by the charger. If the load is higher than charger capacity, the required additional power comes from the battery, which will be progressively discharged until the charger automatically switches back to the bulk phase. Once consumption decreases, the charger goes back to normal operation of the 3-step+ charge system.

As the Mass Combi Ultra is equipped with a 3-step+ charge system, the batteries can also remain connected to the Mass Combi Ultra in winter. One hour every 12 days the charger automatically switches to the Bulk phase to keep the battery working properly and prolong its life span. The 3-step+ charge system is also safe for all the connected equipment.

3.2.2 Temperature compensated charging

The Mass Combi Ultra is delivered with a battery temperature sensor. By installing this battery temperature sensor (for Lead Acid batteries only) the charge voltages are automatically adapted for deviating temperatures. When the battery temperature is low, the charge voltage increases. On the other hand, when the battery temperature is high, the charge voltage is decreased. Overcharge and gassing are prevented this way. This will extend the life of your batteries.

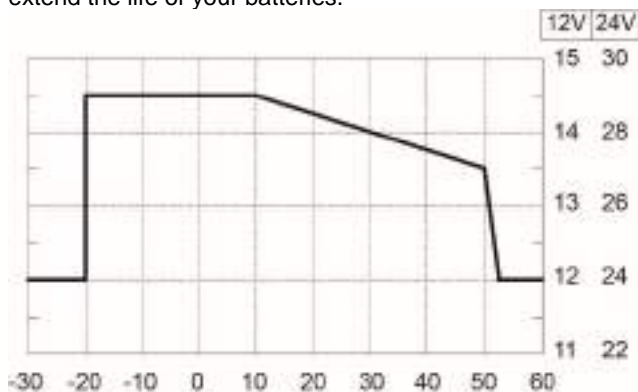

Temperature compensated charging cannot prevent the batteries from overcharging situations.

3.2.3 Connection of a secondary battery

The Mass Combi Ultra is equipped with a secondary charge output to use for charging a small battery set like a starter battery. If the main battery nominal voltage is 24 V, the secondary battery can be 24 V or 12 V. Maximum output current as power supply or battery charger: 10 A.

3.3 Inverter

3.3.1 General

The inverter provides voltage and frequency regulated AC power from a battery bank. Fast acting electronic circuits protect the inverter against extreme overloads, low and high battery voltage and overheating of the inverter.

A large momentary surge power is available for inductive loads, such as electric motors.

3.3.2 Energy saving mode (selectable)

In the inverter mode the Mass Combi Ultra has a built-in automatic energy saving feature that reduces battery power consumption when no load is present on the outputs. Response from idle is instant. In most cases the operation is not noticeable. The energy saving mode can be set by means of MasterBus or dipswitch A4, refer to chapter 6, Configuration.

The Mass Combi Ultra scans the AC outputs with pulses of 230 V every 2½ seconds. When it detects a load that is larger than 50 W (adjustable), it switches On the inverter automatically.



Small loads such as clocks in VCRs or micro waves are most likely not to work in this mode.

3.4 Operation modes

In the next sections different operation modes are described.

3.4.1 Inverting mode

See figure 3-3. When there is no external AC power available, the inverter of the Mass Combi Ultra provides AC power on the AC outputs.

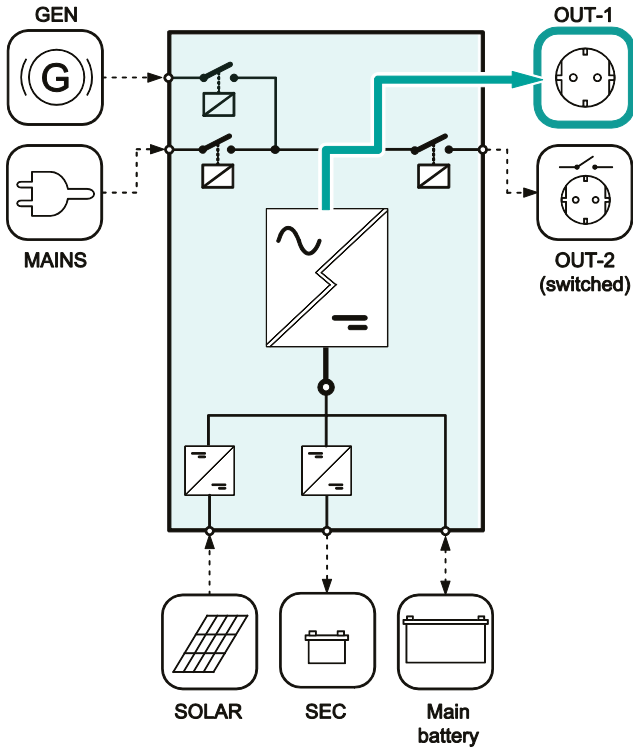

Figure 3-3: Inverting mode

3.4.2 Charging mode

See figure 3-4 and 3-5. When external AC power comes available on the Mains- or Gen input, the main battery will be charged and the AC outputs are supplied by the external power.

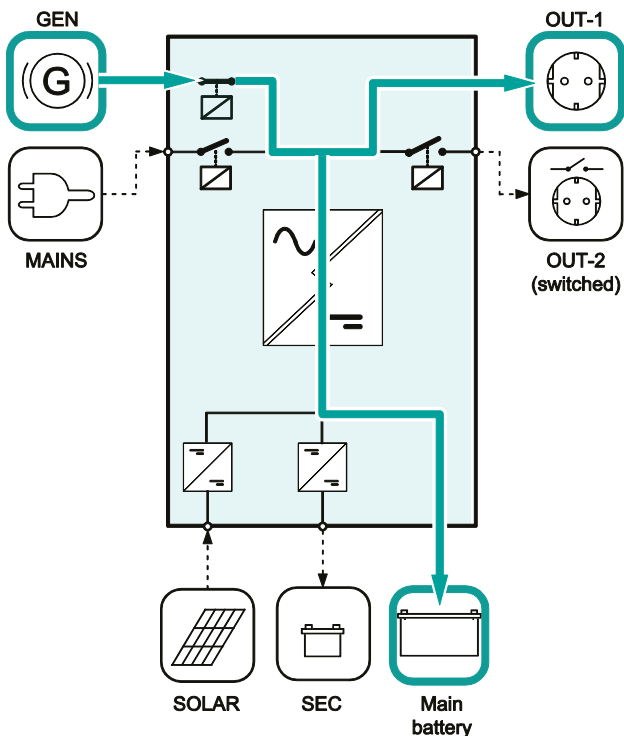

Figure 3-4: AC power from Generator input

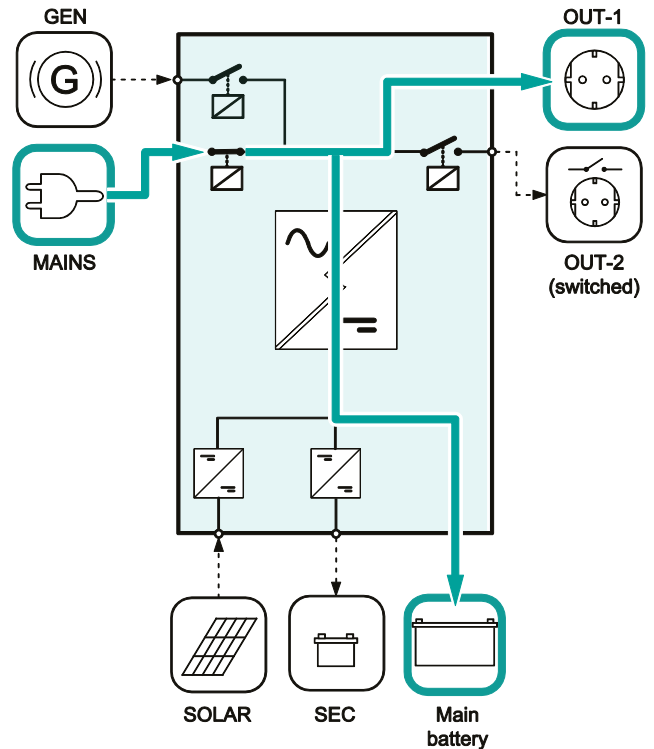

Figure 3-5: AC power from Mains input

3.4.3 Output 1 and 2

See figure 3-6. The Mass Combi ultra has two AC-outputs. AC-power is always available on output 1 and this is the ideal output for loads that need continuous AC-power. Output 2 is only available when external AC power comes available on the Mains- and/or Gen input. Output 2 policy is configurable by the dipswitches locally on the Mass Combi Ultra or a MasterBus monitoring device. (See chapter 4.3.2).

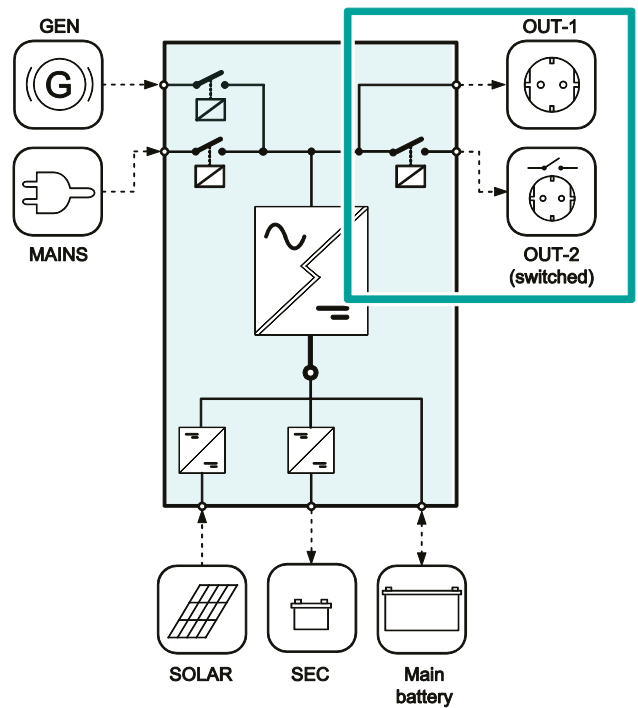

Figure 3-6: Out-1 and Out-2

3.4.4 Power sharing mode

See figure 3-7. If the available power at the AC-input is limited, and the load connected to the AC output increases, the external AC circuit breaker may trip if nothing is done. To avoid this, the Mass Combi Ultra can automatically reduce the battery charger output, and thus the AC power consumption.

The Power Sharing level should be set to match the value of the external circuit breaker, which protects the incoming AC power. For example, when the external AC power is limited by a 6 A fuse, the Power Sharing level must be set to 6 A. When the total connected AC load reaches the level of the Power Sharing setting (6 A), there will be no power left over to charge the battery. This means that the charge current of the Mass Combi will be reduced to 0 A.

The Power Sharing level can be adjusted by means of the DIP-switches locally on the Mass Combi Ultra. However, we recommend the use optional remote control, like the MasterView Easy.

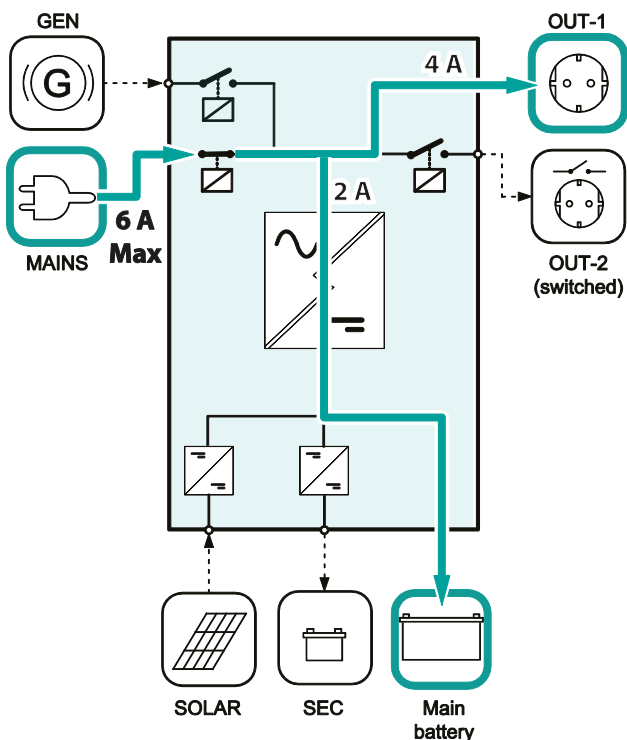

Figure 3-7: Power Sharing level is set to a 6 A while the AC outputs consume a total of 4 A. This means that $6 - 4 = 2$ A is left over for charging.

3.4.5 Gen-/Mains support

See figure 3-8. If the demand for AC power is higher than the available power at the AC-input, the external AC circuit breaker may trip if nothing is done. This problem can be solved by the Generator / mains support function. With the Generator / mains support mode enabled, the inverter will operate in parallel with the external AC power source. This

means that energy from the batteries is added to the AC-output only.

Under no circumstances AC power from the inverter can be fed back into the AC grid. Please mind that several countries maintain different regulations with regard to AC-sources operating in parallel with the AC-grid. This may mean that in some situations the use of the Generator / Mains support function is not allowed. Please acquaint yourself with local regulations on this issue. Never use the Generator / Mains support mode if this is not allowed!

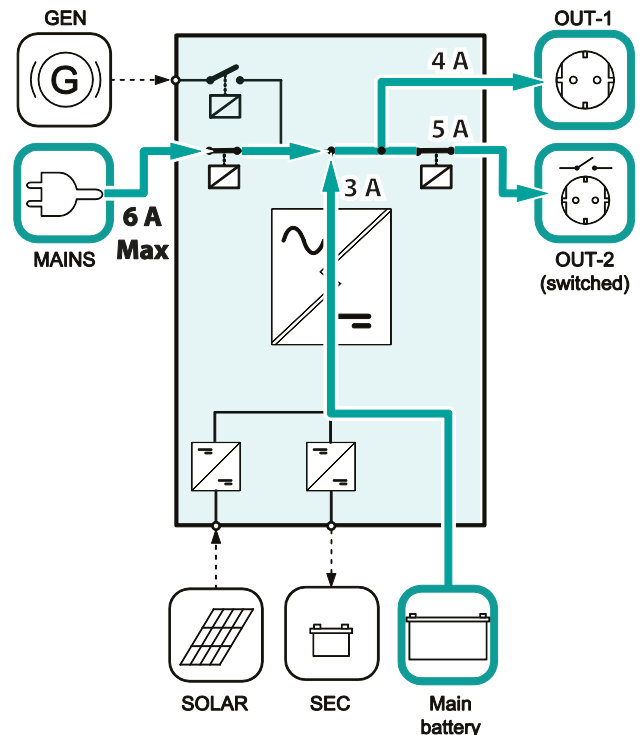

Figure 3-8: Example: The AC-input is limited to 6 A. This is not enough to supply the total load ($4 + 5 = 9$ A) connected to the AC outputs. The inverter will supply the remaining $9 - 6 = 3$ A.

3.4.6 Solar charging

See figure 3-9. DC voltage coming from a solar panel is converted to DC for battery charging. Refer to the specifications for allowable solar string voltages. The available solar charge current will be added to the main charger current.

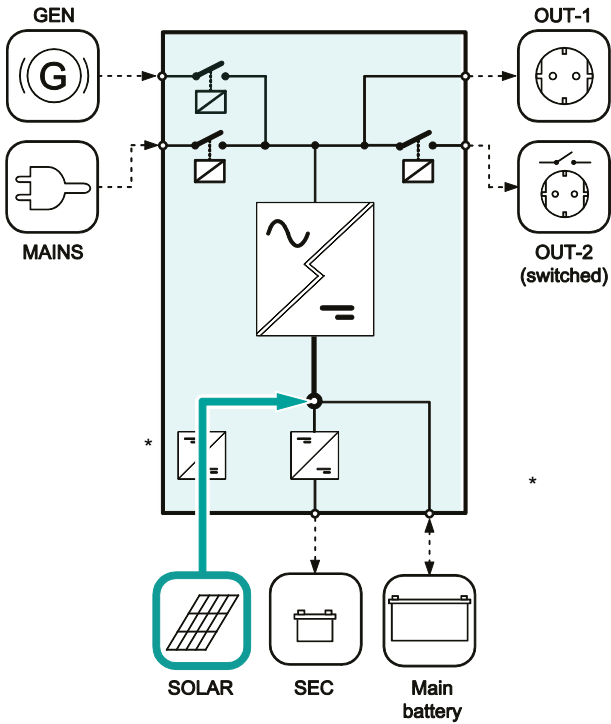

Figure 3-9: Solar charging active

3.4.7 Secondary charging mode

See figure 3-10. The secondary battery charger is suitable for a secondary battery set or as power supply (constant voltage). The secondary charge output is active (charging a secondary battery) when external AC power comes available on the Mains- or Gen input. In power supply mode (constant voltage) the output is also active in inverter mode.

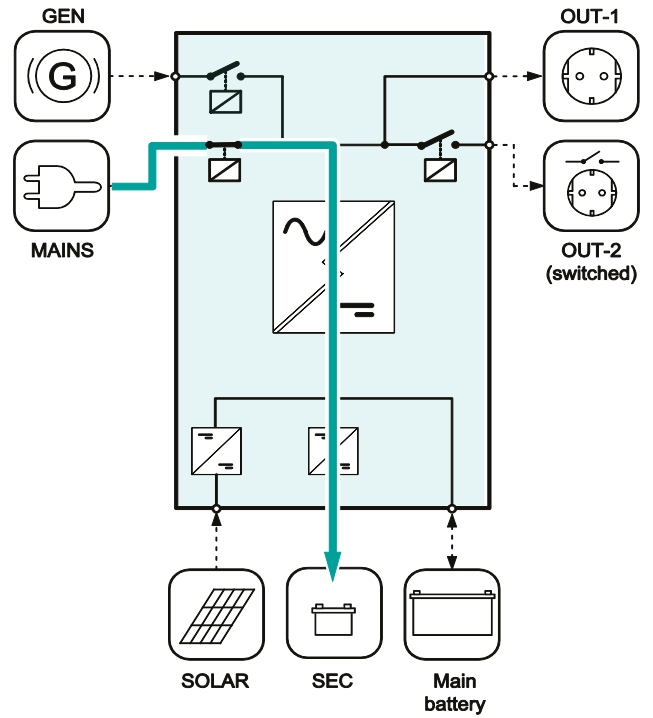

Figure 3-10: Secondary charger active

3.4.8 Silent mode

This is perfect for night-time operation, if little power is consumed. In silent mode the fan speed will be limited to the percentage that is selected during configuration. To avoid too high a temperature, the Mass Combi Ultra will reduce its charging current.

Silent mode is activated by a command-based event. This means that on a control panel like the EasyView 5 for example, a key to activate the Silent mode can be used.

4 OPERATION

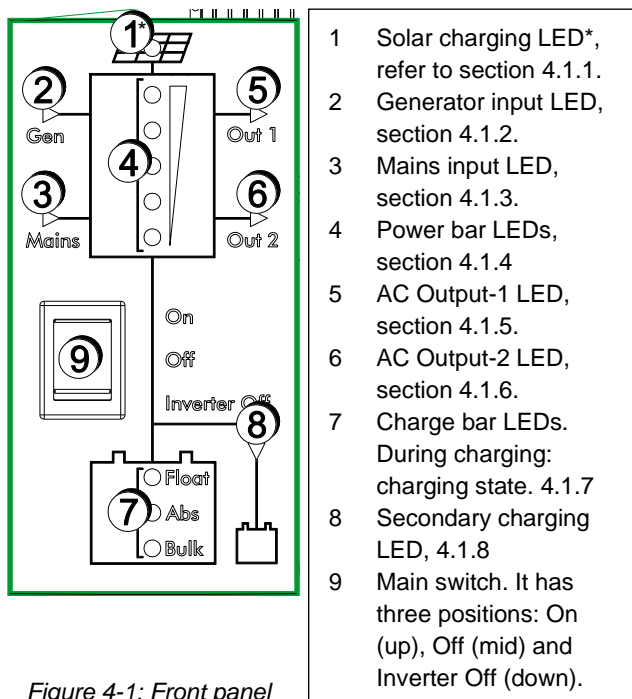

Figure 4-1: Front panel

* Models 12/3000-150 and 24/3500-100 only

4.1 LED indicators

See figure 4-1. The operation of the Mass Combi Ultra is displayed by means of LED indicators at the front side of the housing. If the Mass Combi Ultra is activated and as long as none of the red indicators are illuminated, no failure is detected and the unit is operating normally.

4.1.1 Solar charging LED*

See figure 4-1 item 1. The illuminating top LED indicates there is a DC input from the PV system. This input is used to charge both battery banks.

- On: PV input.
- Off: no PV input.
- Blinking: standby, solar voltage out of range.

4.1.2 Generator input LED

See figure 4-1 item 2. The arrow is illuminated if AC power comes from the generator.

- On: generator input,
- Off: no generator input,
- Blinking: synchronizing,
- Blinking fast: AC input out of range.

4.1.3 Mains input LED

See figure 4-1 item 3. The arrow is illuminated if AC power comes from the mains.

- On: mains input.
- Off: no mains input.
- Blinking: synchronizing.
- Blinking fast: AC input out of range.

4.1.4 Power bar LEDs

See figure 4-1 item 4. These LEDs have a double function, depending on the mode the Combi Ultra is in.

During charging: charge current (20 % of nominal charge current per LED).

During inverting: 20 % of nominal inverter power per LED). If the upper LED illuminates red, the inverter is in overload.

4.1.5 AC Output-1 LED

See figure 4-1 item 5. The illuminated arrow indicates that AC Output-1 is powered.

4.1.6 AC Output-2 LED

See figure 4-1 item 6. The illuminated arrow indicates that switched AC Output-2 is powered.

4.1.7 Charge bar LEDs

See figure 4-1 item 7. The 3-LED bar has two functions.

- During charging the blinking LEDs indicate the charge phase of the 3-step+ charge algorithm.
- During inverting the LEDs give a rough estimation of the battery voltage: the more LEDs are illuminated, the higher the battery voltage.

4.1.8 Secondary charging LED

See figure 4-1 item 8. The illuminating arrow indicates the secondary battery is being charged.

- On: charging.
- Off: not charging.
- Flashing: error.

4.1.9 Main switch

See figure 4-1 item 9. The only control on the Mass Combi Ultra itself is the main switch on the front of the unit. This switch controls on, off and Inverter off (Charger only).

After switching on, expect a three till five second delay before the unit is activated.

With the main switch in position "on", the Combi Ultra inverter can also be switched off and on via MasterBus.

If AC power is available on the AC input and within the specified limits, the Mass Combi Ultra switches on in Charger Mode and will start to charge the batteries. If the AC power from the external AC-source is unavailable or outside the specified limits, the unit switches on as an inverter.

Move the main switch to the "off" position to switch off the Mass Combi Ultra.

If the main switch is set to the Inverter Off-position, the Mass Combi Ultra is only able to work as a charger. This means that the inverter mode is disabled. This setting is useful if you want to keep your batteries charged and maintained in case you have left i.e. in the winter time.

4.2 Protections

The Mass Combi Ultra is protected against overload, short circuit, overheating and under and over voltage. You can detect failures from the front panel or from the MasterBus control panel.



CAUTION!

The Mass Combi Ultra is not protected against reversing polarity of the DC-input, AC voltage on the DC-input and extreme over voltage (>300 VAC) on the AC-input or AC-outputs.

4.2.1 Output overload or short circuit

In case of overload or short circuit during inverter mode, the Power bar top LED illuminates red and the output voltage of the Mass Combi Ultra is limited. Mass Combi Ultra shuts down if this overload or short circuit lasts over 5 seconds. The Mass Combi Ultra will automatically restart after shutdown. After 5 failed start attempts the Mass Combi Ultra shuts down permanently, the Power bar top LED and the Charge bar bottom LED stay blinking red. You can restart the Mass Combi Ultra only by switching the unit manually off and on with the main switch on the Mass Combi Ultra after the overload or short circuit is removed.

4.2.2 Overheating

In the event of overheating the Mass Combi Ultra inverter shuts down, the charger reduces charge current. Overheating is most likely caused by:

- heavy or non-resistive loads operating for a longer period.
- high ambient temperature.
- disrupted air flow (dust or too little space).

As soon as the temperature drops below the factory default threshold, the inverter is powered up automatically or the charger resumes its charge current.

4.2.3 Under and over voltage

The AC-input of the Mass Combi Ultra is, within limits, protected against over and under voltage. See specifications. If the AC-input voltage is out of operating range, the Mass Combi Ultra will switch to inverter mode, disconnecting both AC inputs and it will switch back if the AC-input voltage is within range again. The DC-input of the Mass Combi is also protected against over and under voltage. See specifications. The Mass Combi Ultra switches off if the DC-input voltage is out of range.

4.2.4 Dynamic DC input window

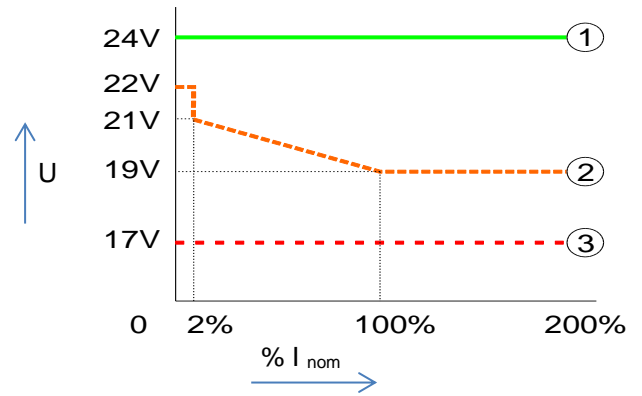

Figure 4-2: Dynamic DC input window

The Dynamic DC input window is used to switch off depending on both the battery voltage and current. The reason for this is that low current loads cause a small voltage drop but they are responsible for severe battery damage.

Shown in figure 4-2 is the graph for a 24 V lead acid battery. The graph shows three lines:

- (1) Low voltage switch on. Above this voltage the inverter switches on.
- (2) Low voltage switch off with delay. Below this line the inverter switches off after a delay.
- (3) Low voltage switch off without delay. Below this line the inverter switches off without delay.

4.3 Operation policies

Via MasterBus configuration, the preferred behaviour of AC in and outputs can be set.

4.3.1 AC input policy

| Preference | Description |
|--------------------|-------------------------------------|
| Mains preferent | Mains input is preferred |
| Gen preferent | Generator input is preferred |
| Max fuse preferent | AC source with highest fuse setting |
| Mains only | No generator |
| Generator only | No mains |

4.3.2 AC Output-2 policy

| Preference | Description |
|-----------------|-------------------------------|
| Events only | Operation manually |
| Generator input | Generator input only |
| Mains input | Mains input only |
| Gen/mains input | Generator or main input |
| Always on | Always connected to the loads |

By default, AC power is only available on AC output 2 if external power is available on the Main or Gen input.

See section 6.2, AC transfer, to change the operation preferences of AC output 2.

4.3.3 Secondary charging policy

Secondary battery charging takes place when:

- activated by the Force sec charge event (section 6.2.3);
- charging from AC input;
- set to a constant voltage (section 6.1, 6.2).

4.4 Maintenance

Checking all connections every 6 months is required.

Further, no specific maintenance is required. If necessary, use a soft clean cloth to clean the Mass Combi Ultra. Do not use any liquids or corrosive substances, such as solvents, alcohol, petrol or abrasive components.

4.5 Daily use, MasterBus monitoring

Below table shows the MasterBus Monitoring page. On this page you can adjust the daily settings.

| Value | Meaning | Default | Range | Group-item | Index |
|---------------------|---|---------|--|------------|-------|
| General | | | | | |
| Device state | The state of your Mass Combi Ultra | | Standby; Inverting; Alarm; Charging; Supporting; Overload; Low battery | 1 - 1 | 16 |
| Mains fuse | Mains fuse rating | 25 A | 1..30 A | 1 - 2 | 19 |
| Inverter | Option to switch Off the inverter to prevent depleting of your batteries. | On | On; Off | 1 - 3 | 20 |
| Mode | User mode | | Initializing; On; Standby; Inverter off; Charger off | 1 - 4 | 60 |
| AC in state | State of the AC input | | No AC present, Generator, Mains, Poor quality | 1 - 5 | 4 |
| AC out state | State of the AC output | | No AC output, AC out1 only, AC out1&2 | 1 - 6 | 5 |
| Main charger | Main charger state | | On; Off | 1 - 7 | 58 |
| Sec. charger | Secondary charger state | On | Off; On | 1 - 8 | 14 |
| Solar charger* | Solar charger state | On | Off; On | 1 - 9 | 15 |
| Battery (DC) | | | | | |
| Main charger | Main battery state of charger | | Bulk; Absorption; Float; Standby; Const. volt | 2 - 1 | 18 |
| Main battery | Main battery voltage | | 0..16 V; 0..32 V; 0..64 V | 2 - 2 | 6 |
| Main battery | Main battery current (minus is discharging) | | -500..500 A | 2 - 3 | 7 |
| Battery temp | Main battery temperature | | -25..50 °C, if not connected: --- | 2 - 4 | 21 |
| Shunt device | Selected shunt device for the main battery | | | 2 - 5 | 22 |
| Battery SoC | Main battery state of charge | | 0..100% | 2 - 6 | 23 |
| Sec. charger | Secondary battery charger state | | Bulk; Absorption; Float; Standby; Const. volt; Error | 3 - 1 | 46 |
| Sec. battery | Secondary battery voltage | | 10..30 V | 3 - 2 | 43 |
| Sec. battery | Secondary battery current | | 0..10 A | 3 - 3 | 44 |
| AC inputs | | | | | |
| Mains | Mains voltage | | 0..300 V | 4 - 1 | 8 |
| Mains | Mains current | | 0..50 A | 4 - 2 | 9 |
| Mains | Mains power | | 0..10000 W | 4 - 3 | 94 |
| Generator | Generator voltage | | 0..300 V | 4 - 4 | 95 |
| Generator | Generator current | | 0..50 A | 4 - 5 | 96 |
| Generator | Generator power | | 0..20000 W | 4 - 6 | 97 |
| AC outputs | | | | | |
| AC output 1 | AC output 1 voltage | | 0..300 V | 5 - 1 | 10 |
| AC output 1 | AC output 1 current | | 0..70 A | 5 - 2 | 11 |
| AC output 1 | AC output 1 power | | 0..20000 W | 5 - 3 | 98 |
| AC output 2 | AC output 2 voltage | | 0..300 V | 5 - 4 | 99 |
| AC output 2 | AC output 2 current | | 0..70 A | 5 - 5 | 100 |
| AC output 2 | AC output 2 power | | 0..20000 W | 5 - 6 | 101 |
| Solar input* | | | | | |
| Solar state | State of solar charger | | Standby; Charging; Error | 6 - 1 | 42 |
| Solar input* | Solar DC power | | 0..500 W | 6 - 2 | 41 |
| Solar input* | Solar DC voltage | | 0..100 V | 6 - 3 | 39 |
| Solar input* | Solar DC current | | 0..20 A | 6 - 4 | 40 |

* Models 12/3000-150 and 24/3500-100 only

5 INSTALLATION

During installation and commissioning of the Mass Combi Ultra, the Safety Guidelines & Measures are applicable at all times. See chapter 2 of this manual.

5.1 Unpacking

In addition to the Mass Combi Ultra the delivery includes:

- a battery temperature sensor;
- this user manual;
- MasterBus terminating device.

After unpacking, check the contents for possible damage. Do not use the product if it is damaged. If in doubt, contact your supplier.

Check from the identification label (see section 1.6) whether your Main battery voltage is the same as the DC-input voltage of the Mass Combi Ultra (e.g. 24 V main battery set for a 24 V input voltage). Also check that the AC output voltage and output power of the Mass Combi Ultra complies with your system and loads.

5.2 Environment

Obey the following stipulations during installation:

- The Mass Combi Ultra is designed for indoor use only.
- Ambient temperature: -25 °C to 60 °C, (power derating above 40 °C).
- Maximum usage/installation height: 2000 m.
- Humidity: 0-95 % non-condensing.
- Mount the Mass Combi Ultra on a solid surface, with the connecting cables downwards.
- Make sure that the hot air produced during operation can be discharged. The Mass Combi Ultra must be mounted in such a way that obstruction of the airflow through the ventilation openings will be prevented.
- No objects must be located within a distance of 10 cm / 4 inch around the Mass Combi Ultra. Keep at least 15 cm / 6 inch free space below the Mass Combi Ultra.
- Do not locate the Mass Combi Ultra in the same compartment as the batteries.
- Do not install the Mass Combi Ultra straight above the batteries because of possible corrosive fumes.

5.3 Wiring

The wiring is connected inside the connection compartment. If necessary, the wiring can be fed from the top to the bottom side of the cabinet along the back of the cabinet.

Always use the strain reliefs to fix the wiring. Fix the phase line wire to terminal L, the neutral wire to terminal N and the ground wire to terminal PE, see figure 5-1.

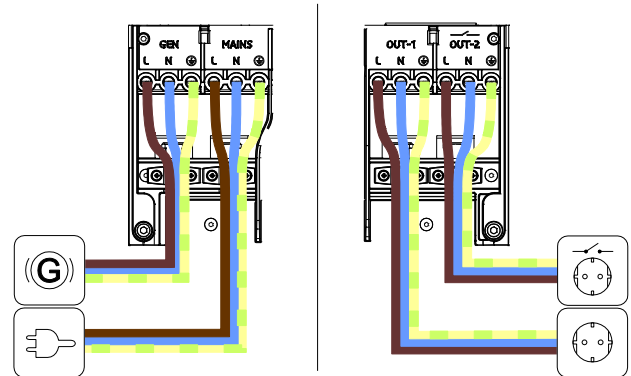

Figure 5-1: AC terminal connections



WARNING

NEVER connect shore power to the generator input. This may result in an electric shock!

5.3.1 AC-wiring

For a safe installation the correct wire cross section must be applied. Don't use a cross section that is smaller than indicated. See table below to select the appropriate cross section for the AC wiring:

| AC-Current | Minimum cross section: | |
|------------|------------------------|--------|
| 0-20 A | 2.5 mm ² | AWG 13 |
| 20-32 A | 4 mm ² | AWG 11 |
| 32-48 A | 6 mm ² | AWG 9 |
| 48-80 A | 10 mm ² | AWG 7 |

Recommended wire colours (refer to local rules and fig 5-1)

| Wire color | Meaning | Connected to: |
|----------------|---------|---------------|
| Brown or black | Phase | L1 |
| Blue | Neutral | N |
| Green/Yellow | Earth | PE / GND |

The current entering the Mass Combi Ultra must be limited. Therefore the AC-input must be protected by a fuse in the L cable, as specified below. Maximum rating of the generator AC input fuse: 50 A and Mains AC input fuse: 30 A. The PE/GND cable cross section must be at least equal to L1.

5.3.2 DC wiring

Keep in mind that high current will pass through the DC wiring. Keep the cable length as short as possible, this will keep the system efficiency as high as possible. The table shows recommended DC wire sizes:

| Model | Minimum cross section: | |
|---------------|------------------------|---------|
| 12/3000 - 150 | 95 mm ² | 4/0 AWG |
| 24/3500 - 100 | 50 mm ² | 0 AWG |
| 48/3500 - 50 | 25 mm ² | 3 AWG |

Use M8 cable lugs terminals on the ends of the wires. These lugs should be crimped with a proper crimping tool. Use the following wire colours for DC wiring (refer to local rules):

| Wire colour | Meaning | Must be connected to: |
|-------------|----------|-----------------------|
| Red | Positive | + (POS) |
| Black | Negative | - (NEG) |

Position the positive and negative cables next to each other to limit the electromagnetic field around the cables. The negative cable should be connected directly to the negative post of the battery bank or the load side of a current shunt. Do not use the chassis frame or hull of the ship as the negative conductor. Tighten the DC connections securely (15 - 20 Nm / 130 - 175 In-Lbs.). The positive battery cable must be fused and connected to the positive post of the battery bank. Fuse rating depends on the applied cable cross section.

5.3.3 AC safety grounding



WARNING

The ground wire offers protection only if the cabinet of the Mass Combi Ultra is connected to the safety ground.

The ground stud (M6) is positioned at the left side of the cabinet, see page 2, position 12. Connect the earth terminal (PE / GND) to the hull or the chassis with a minimum 10 mm².

In some applications automatic connection between the neutral conductor (N) and earth (PE / GND) is not required or acceptable. Therefore the automatic connection between the neutral conductor (N) and earth (PE / GND) is disabled by default.

For safe installation it is necessary to insert a Residual Current Device (earth leakage switch) of 30 mA in the AC in and outputs of the Mass Combi Ultra. Refer to local regulations on these issues!

5.4 Things you need

Make sure you have all the parts you need to install the Mass Combi Ultra:

- Mass Combi Ultra (included).
- Battery temperature sensor with cable and plug (included).
- AC wiring. Double insulated three wire cable with wire colours according to the locally applicable standards. The applicable length and wire diameter depend on the electrical installation. See section 5.3.1.
- DC-wiring to connect the DC connections of the Mass Combi Ultra to the DC-distribution; see section 5.3.2.
- DC-fuse holder with a DC-fuse, to be integrated in the positive DC-cable. For specifications see section 5.3.2.
- Screws / bolts (Ø 6 mm) (with plugs) to mount the cabinet to a surface. Use mounting materials which are suitable to carry the weight of the Mass Combi Ultra.
- Batteries. Refer to chapter 8 for specifications.
- Appropriate and reliable cable terminals, cable lugs, battery terminals and cord end terminals.

We recommend as a minimum tool kit:

- Socket wrench 13 mm to fix the DC-input (battery) cables.
- Flat blade screw driver 1.0 x 4.0 mm to fix the screw terminals.
- Tools to fix the screws / bolts (Ø 6 mm) with plugs to mount the cabinets to a surface.
- Philips screw driver to open the connection area of the Mass Combi Ultra.

5.5 Removal of the front lid

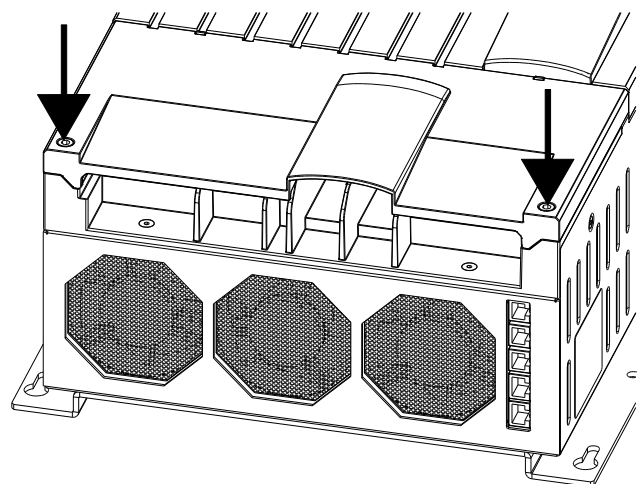

Figure 5-2: Removal of the front lid

Steps:

- 1 Loosen the two screws that secure the front cover plate.
- 2 Lift the front cover plate from the cabinet; see figure 5-3.

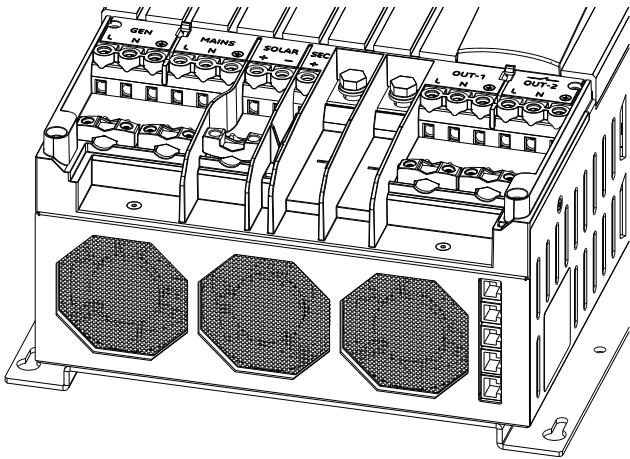

Figure 5-3: Front lid removed

**WARNING**

The front panel must not be removed while the Mass Combi Ultra is still connected to a power source!

5.6 Mounting the cabinet to a surface

M6 bolts can be used for the mounting of the cabinet vertically to a surface.

Take the following steps to mount the cabinet:

- 1 Determine for the four mounting spots on the basis of the outline drawings and 150 mm of free space required below the Mass Combi Ultra for installation and DIP switch operation.
- 2 Screw the topmost bolts somewhat into the wall.
- 3 Hang the cabinet with its key holes over the two bolts and screw these bolts finger tight, so shifting is still possible.
- 4 Place the two lowermost bolts.
- 5 Fasten all bolts securely.

5.7 Wiring instructions**WARNING**

Have installation work done by a licensed electrician only. Before connecting the wiring, make the AC distribution as well as the DC distribution voltage free. Move the main switch to the "Off"-position.

**CAUTION!**

Short circuiting or reversing polarity may lead to serious damage to the batteries, the Mass Combi Ultra, the solar panels, the wiring and/or the terminal connections. Fuses between the batteries and the Mass Combi Ultra cannot prevent damage caused by reversed polarity. The damage as a result of reverse polarity is not covered by the warranty.

**CAUTION!**

Too-thin cables and/or loose connections can cause dangerous overheating of the cables and/or terminals. Therefore tighten all connections well. Only use cables of the correct size.

5.8 Installation overview

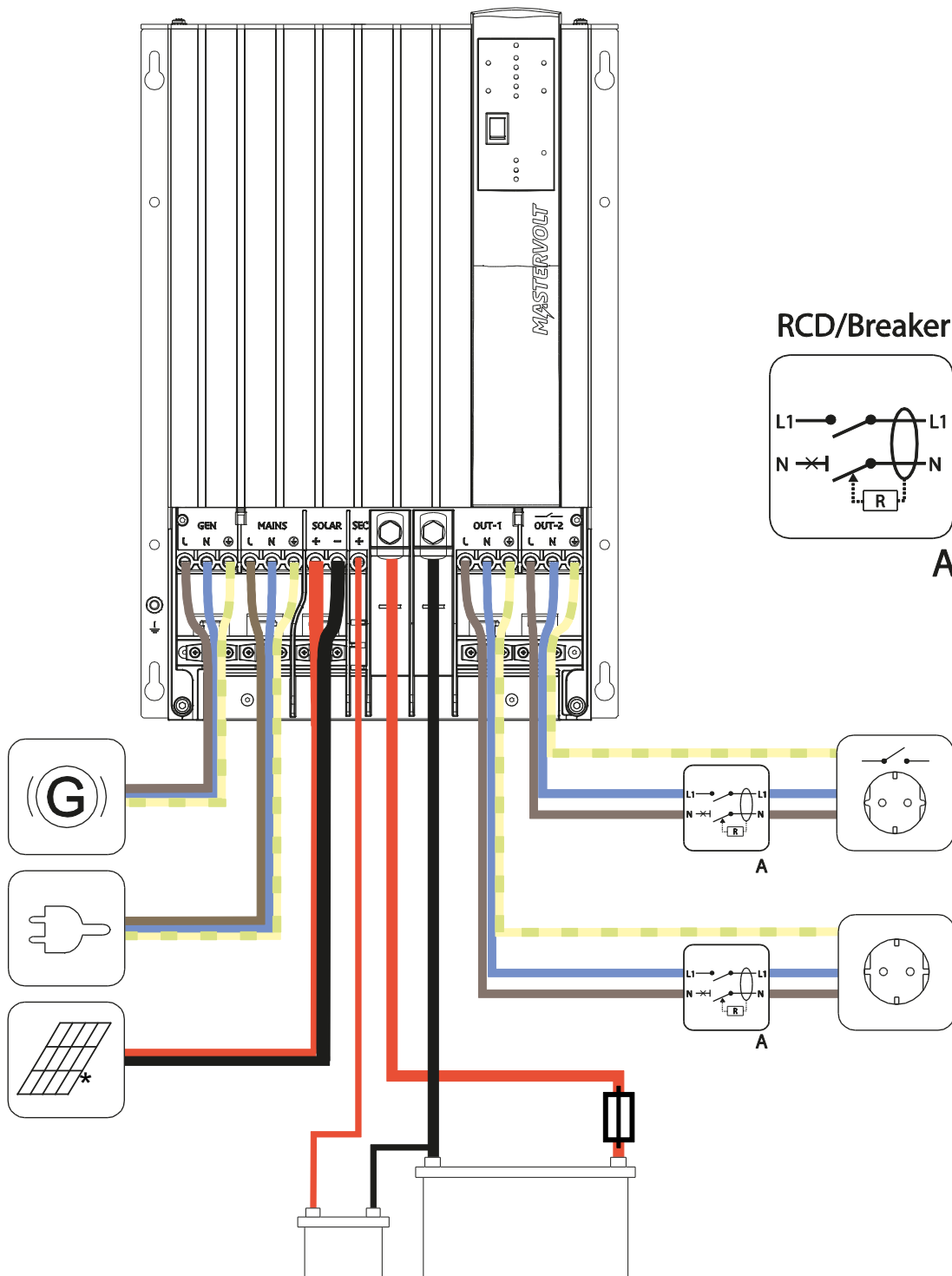

* Models 12/3000-150 and 24/3500-100 only

Figure 5-4: Installation overview for one Mass Combi (stand-alone operation)



CAUTION!

Ensure correct polarities, cross sections and fuses for all wiring. An RCD according to local regulations must be connected to output-1 and 2.

5.9 Setting up a MasterBus network

M All devices that are suitable for MasterBus are marked by the MasterBus symbol.

MasterBus is a fully decentralized data network for communication between the different Mastervolt system devices. It is CAN-bus based which has proven itself as a reliable bus-system in automotive applications. MasterBus is used as power management system for all connected devices, such as the inverter, battery charger, generator and many more. This enables communication between the connected devices, for instance to start the generator when the batteries are low. MasterBus reduces complexity of electrical systems by using UTP patch cables. All system components are simply chained together. Therefore each device is equipped with two MasterBus data ports. As only a few MasterBus cables are needed, installation and material costs are reduced importantly.

New devices can be added to the existing network easily. Consequently the MasterBus network is highly flexible for extended system configuration. Mastervolt also offers several interfaces like the Modbus interface, making even non-MasterBus devices suitable to operate in the MasterBus network. For central monitoring and control of the connected devices Mastervolt offers different panels, like the full colour MasterView System panel. All monitoring panels can be used for monitoring, control and configuration of all connected MasterBus equipment.

CAUTION! Never connect a non-MasterBus device to the MasterBus network directly! This will void warranty of all MasterBus devices connected.

5.10 How to set up a MasterBus network

Every MasterBus device is equipped with two data ports. When two or more devices are connected via these ports, a local data network called the MasterBus is formed. Keep the following rules in mind:

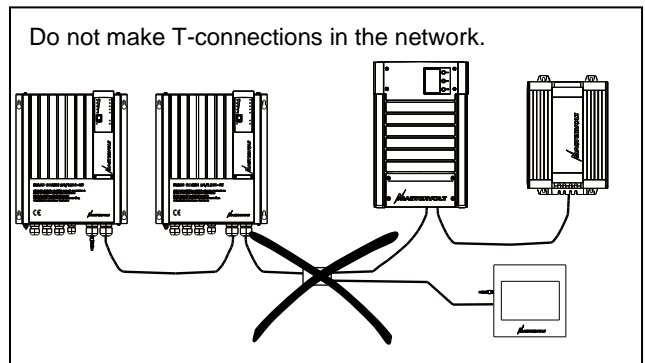
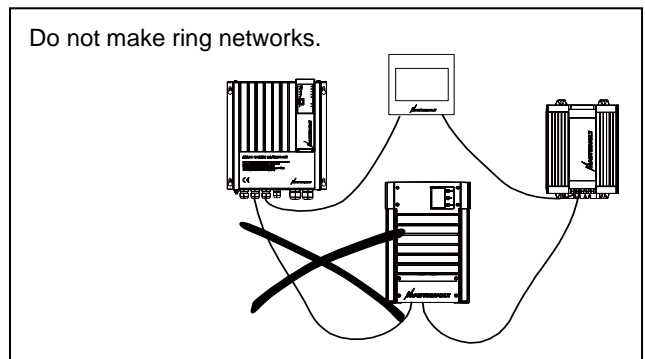
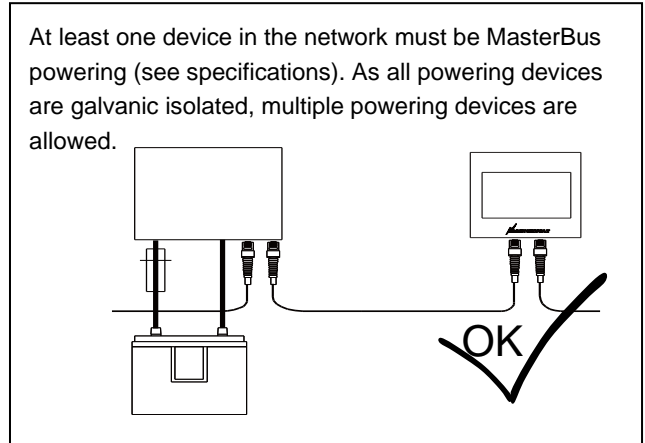
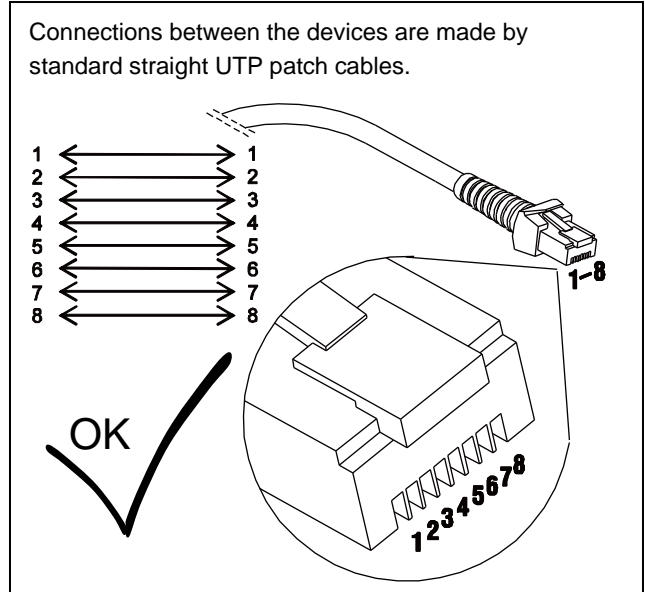
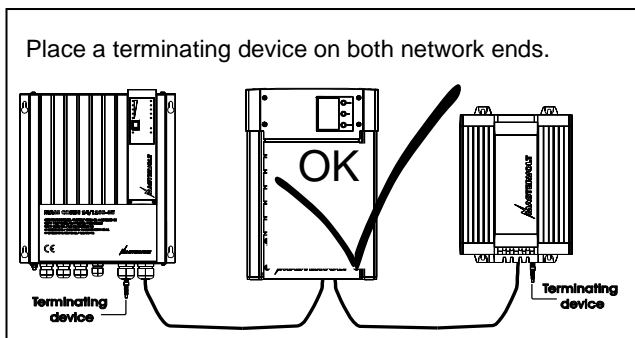

6 CONFIGURATION

The Mass Combi Ultra is provided with two groups of DIP-switches to adjust the Mass Combi Ultra according to the specifications of the electrical installation, see figure 6-1. DIP-switch settings are 0 for default values. The Mass Combi Ultra also features the more sophisticated MasterBus configuration.

Previously done MasterBus settings are overruled by the DIP-switch settings and they are greyed out in the menu. When a DIP-switch is set to 0, the corresponding MasterBus setting becomes default too, regardless the previous setting.

6.1 Configuration via DIP-switches

The DIP-switches are located in the connection compartment. Figure 6-1 shows the location of the DIP-switches and the print on the inside of the front cover plate.

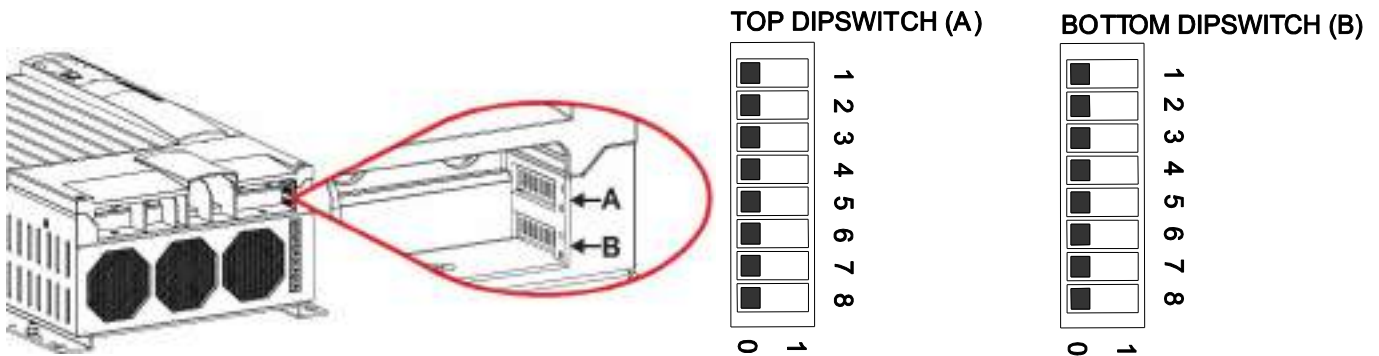

Figure 6-1: DIP-switches and cover print

| DIP switch | Function | | | | |
|------------|--------------------------------|---------------------|----------------------------|-------------------------------|---|
| A1-A2 | Parallel mode | 0-0: Stand alone | 1-0: Master 0 | 0-1: Slave | 1-1: NA |
| A3 | Output frequency inverter | 0: 50 Hz | | 1: 60 Hz | |
| A4 | Energy saving mode | 0: off | | 1: on (scan mode) | |
| A5-A6 | Secondary charger | 12/3000 | 0-0: Follow main battery * | | |
| | | 24/3500 | 0-0: Follow main battery * | 1-0: 24 V constant voltage ** | 0-1: 12 V 3Step+ * 1-1: 12 V constant voltage ** |
| | | 48/3500 | 0-0: 24 V 3Step+ * | 1-0: 24 V constant voltage ** | 0-1: 12 V 3Step+ * 1-1: 12 V constant voltage ** |
| A7-A8 | Main battery type | 0-0: Flooded | 1-0: Gel | 0-1: AGM | 1-1: Flooded traction |
| B1-B2 | Fuse setting mains input | 0-0: 30 A | 1-0: 16 A | 0-1: 10 A | 1-1: 6 A |
| B3 | Fuse setting generator input | 0: 25 A | | 1: 50 A | |
| B4 | Power sharing mode | 0: enabled | | 1: disabled | |
| B5 | Generator / Mains support mode | 0: disabled | | 1: enabled | |
| B6 | AC voltage input window | 0: wide (+/-40 V) | | 1: narrow (+/-23 V) | |
| B7 | Generator AC frequency window | 0: wide (+8/-10 Hz) | | 1: narrow (+/-5 Hz) | |
| B8 | Ground relay | 0: disabled | | 1: enabled | |

* Secondary battery charging only takes place when the main charger is active.

** In constant voltage mode the secondary output voltage cannot be higher than the main battery voltage.

6.1.1 Ground relay

For safe installation:

- Residual Current Devices (RCD) must be integrated in the AC inputs and AC outputs of the Mass Combi Ultra.
- The neutral conductor (N) of the AC output of the Inverter must be connected to the safety ground (PE/GND) when the Mass Combi Ultra is working as an inverter.

The ground relay function allows you to connect the Neutral conductor (N) of the inverter output circuit to the Safety Ground (PE / GND) automatically when the Mass Combi is working as an inverter. Refer to local standards on this issue.

6.2 MasterBus configuration

Parameters below can be changed via the MasterBus network. DIP switch settings overrule MasterBus settings. If DIP switches are not set to default, the corresponding MasterBus configuration is greyed out

| Value | Meaning | Default | Adjustable range |
|---------------------|---|------------------------------|--|
| Device | | | |
| Language | Language that is displayed on a monitoring device connected to the MasterBus | English | English, Nederlands, Deutsch, Français, Castellano, Italiano, Norsk, Svenska, Suomi, Dansk |
| Device name | Name of this particular device in MasterBus. This name will be recognized by all devices that are connected to the MasterBus network. | MCU [Serial number] | All names with a maximum of 12 characters. |
| Lock config | Option to lock the configuration (installer login). | Not checked | Not checked, Checked |
| Factory settings | Option to reset the configuration to default (installer login). | Not selected | Not checked, Selected |
| System | | | |
| MasterBus power | Checkbox to have the Combi power MasterBus or not. | Checked | Checked, Not checked |
| Silent mode | Activate this mode to reduce the sound of the cooling fans. This may affect the charging time. | Not checked | Not checked, Checked |
| Silent mode | Maximum fan speed | 36 % | 25-100 % |
| Shunt device select | Select a device in the list, the values of which must be used by the Mass Combi Ultra. | No shunt | Shunt devices in the list |
| Main charger | | | |
| Maximum current | Maximum charging current adjustable. | 100 A | 1..150 A/1..100 A/1..50 A |
| Method | Charging method selectable. | 3-Step +, refer to chapter 3 | 3-Step+, constant voltage |
| Battery type | Select the main battery type. | Flooded (Lead acid wet cell) | User defined, Flooded, Gel, AGM, Spiral, MLI, Flooded traction, Nickel Cadmium |
| Bulk | | | |
| Bulk voltage | Maximum Bulk voltage (adjustable if User Defined). | 14.40/28.80/57.60 V | 8..16.00/16..32.00/32..64.00 V |
| Min bulk time | Minimum time that the charger stays in Bulk mode. | 2 min | 0-600 min |
| Start bulk time | Voltage at which to start the bulk timer. | 13.25/26.50/53.00 | |
| Max bulk time | Maximum time the bulk phase lasts before the charger changes to absorption. | 480 min | 0-600 min, Max bulk time > Min bulk time |
| Bulk ret. volt. | Bulk return voltage. If the battery voltage has dropped below this voltage, the charger will return to bulk phase. | 12.8/25.6/51.2 V | |
| Bulk return time | Delay time before the charger returns to Bulk after reaching the Return to Bulk voltage. | 30 s | 0-255 s |
| Absorption | | | |
| Abs. voltage | Absorption voltage (adjustable if User Defined is selected). | 14.25/28.50/57.0 V | 8-16.00/16-32.00/32-64.00 V |
| Max absorp.time | Maximum time that the charger stays in absorption mode. | 240 min | 1-65535 min |
| Return amps | Charging current at which the charger changes to Float phase. | 9.0 A/6.0 A/3.0 A | 0.0-25.0 |
| Min absorp.time | Minimum time that the charger stays in absorption mode. | 15 min | 0-255 min |

| Value | Meaning | Default | Adjustable range |
|-----------------------|--|------------------------------|---|
| Float settings | | | |
| Float voltage | Float voltage (adjustable if User Defined). | 13.25/26.50/53.0 V | 8-16.00/16-32.00/32-64.00 V |
| Sec. charger | | | |
| Maximum current | Maximum charging current adjustable | 10 A | 1-10 A |
| Method | Charging method selectable | Follow main | 12V: follow main, events only 24/48V: follow main, 3-Step+, constant voltage |
| Battery type | Select the main battery type | Flooded (Lead acid wet cell) | User defined, Flooded, Gel, AGM, Spiral, Lithium Ion, Flooded traction, Nickel Cadmium |
| Inverter | | | |
| Voltage | AC voltage | 230 V | 180-260 V |
| Frequency | AC frequency | 50 Hz | 50 Hz, 60 Hz |
| Enable GND rel. | Option to enable ground relay | Not checked | Not checked, checked |
| Energy save mode | Option to enable Energy save mode | Not checked | Not checked, checked |
| Scanning below | The Combi starts scanning below this inverted power level in Energy save mode. | 10 W | 10-250 W |
| Dynamic window | Select to base the input window upon battery type default values or upon your own preset values. Refer to section 4.2.4 | Use battery type | Use battery type, user defined (Use battery type: dynamic input window still present, but not configurable) |
| DC high off | High battery voltage for inverter switch off (12/24/48 V, user defined only). | 16.00/32.00/64.00 V | 13.00-16.00/26.00-32.00/52.00-64.00 V |
| DC high on | High battery voltage for inverter switch to DC High Off alarm (12/24/48 V, user def.) | 15.50/31.00/62.00 V | 13.00-16.00/26.00-32.00/52.00-64.00 V |
| DC low off I=0% | Low battery voltage at which the inverter switches off when the battery current is 0-2% of nominal (12/24/48 V, user def.) | 10.00/20.00/40.00 V | 9.50-13.00/19.00-26.00/38.00-52.00 V |
| DC low off I=2% | Low battery voltage at which the inverter switches off when the battery current is 2% of nominal (12/24/48 V, user def.) | 9.75/19.50/39.00 V | 9.50-13.00/19.00-26.00/38.00-52.00 V |
| DC low off 100% | Low battery inverter switch off voltage, batt. current 100% (12/24/48 V, user def.) | 9.50/19.00/38.00 V | 9.50-13.00/19.00-26.00/38.00-52.00 V |
| DC low on | Low battery inverter switch on voltage at DC Low off alarm (12/24/48 V, user def.) | 12.00/24.00/48.00 V | 10.00-13.00/20.00-26.00/40.00-52.00 V |
| DC low off delay | Delay time before inverter switches off on low battery voltage. | 30 s | 0-30 s |
| AC transfer | | | |
| AC input policy | Define which AC input to be used under which conditions, refer to section 4.3 | Gen preferent | Mains preferent, Gen preferent, Max fuse prefer |
| AC out 2 policy | Define under which conditions to use AC output-2, refer to section 4.3 | Gen/Mains input | Events only, Generator input, Mains input, Gen/Mains input, Always on |
| Generator fuse | Generator fuse value | 25 A | 1-50 A |
| Mains fuse max. | Mains fuse maximum value that can be set in the monitoring tab | 30 A | 1-30 A |
| Mains limit A | Mains fuse value setting | 6 A | 1-30 A |
| Mains limit B | Mains fuse value 10 A | 10 A | 1-30 A |
| Mains limit C | Mains fuse value 16 A | 16 A | 1-30 A |
| Power sharing | Power sharing mode option, chapter 3. | Checked | Not checked, checked |
| Allow AC support | AC support mode option, chapter 3. | Not checked | Not checked, checked |
| Gen. high volt. | Generator AC input window | 275 V | 184-275 V |
| Gen. low volt. | Generator AC input window | 180 V | 184-275 V |

| Value | Meaning | Default | Adjustable range |
|------------------|-----------------------------------|---------|------------------|
| Gen. high freq. | Generator AC input window | 58 Hz | 36-68 Hz |
| Gen. low freq. | Generator AC input window | 40 Hz | 36-67 Hz |
| Generator delay | Time to trigger a Generator alarm | 10 s | 5 – 300 s |
| Mains high volt. | Mains AC input window | 275 V | 184-275 V |
| Mains low volt. | Mains AC input window | 180 V | 184-275 V |
| Mains high freq. | Mains AC input window | 65 Hz | 35-68 Hz |
| Mains low freq. | Mains AC input window | 40 Hz | 35-68 Hz |
| Mains delay | Time to trigger a Mains alarm | 10 s | 5-20 s |

6.2.1 MasterBus alarms

This is the Mass Combi Ultra list of MasterBus alarms with their meaning

| Alarm | Description |
|------------------|---|
| Overload | Combi in overload. The loads exceed the nominal inverter power. |
| Over temperature | Internal temperature of the Combi is too high. |
| Battery low | Main battery voltage is too low. |
| Battery high | Main battery voltage is too high. |
| Batt temperature | Battery temperature is out of range. |
| Temp sense error | An error has been detected in the temperature sensor signal. |
| Sync. error | Two or more Mass Combi Ultra units in a multiple configuration do not synchronize well. |
| Config error | Configuration error, most often in multi Combi installations. Check MasterBus and DIP switch settings. |
| Install error | Installation error around the Combi Ultra, not inside the unit. Check all connections. |
| System error | Internal Combi Ultra error. Contact your Mastervolt supplier. |
| Cable losses | Cable between Mass Combi Ultra and battery is too thin causing too high voltage drops |
| Shunt Mismatch | Setting for nominal voltage (12, 24 or 48 V) at the MasterShunt or the nominal voltage of the MLI batteries differs from nominal voltage detected by the Mass Combi Ultra. Check battery voltage and settings of the MasterShunt or voltage of the MLI Ultra battery. |

6.2.2 List of event sources

This is the Mass Combi Ultra list of event sources. These can initiate an event at another MasterBus connected device.

| Event source | Description |
|-----------------|--|
| Disabled | (no event programmed) |
| Inverting | The Mass Combi Ultra is in Inverter mode |
| Charging | The Mass Combi Ultra is in Charge mode |
| Supporting | The Mass Combi Ultra is in Supporting mode |
| Overload | The inverter current is too large |
| Low bat | The main battery voltage has dropped below the Low bat value |
| Alarm | A Mass Combi Ultra alarm has been triggered |
| Generator input | Generator input ("GEN") is present |
| Mains input | Mains input ("MAINS") is present |
| ACout 2 enabled | Switched Output-2 is enabled |
| Sec charging | The second battery is being charged |
| Solar charging* | Solar powered charging takes place |
| Bulk | Charge phase Bulk |
| Absorption | Charge phase Absorption |
| Float | Charge phase Float |
| External fan | Trigger point to activate an external cooling fan |
| Silent mode | The Mass Combi Ultra is in Silence mode |

* Models 12/3000-150 and 24/3500-100 only

6.2.3 List of event commands

This is the Mass Combi Ultra event commands list. Other MasterBus connected devices can be configured to initiate these commands

| Event command | Description |
|----------------------|---|
| Inverter On/Off | Change the Mass Combi Ultra inverter state to On/Off |
| Charger On/Off | Change the Mass Combi Ultra charger state to On/ Off |
| Bulk | Changes to charge phase Bulk |
| Absorption | Changes to charge phase Absorption |
| Float | Changes to charge phase Float |
| Mains limit A | Fuse setting of the Mains input is set to 6 A (adjustable) |
| Mains limit B | Fuse setting of the Mains input is set to 10 A (adjustable) |
| Mains limit C | Fuse setting of the Mains input is set to 16 A (adjustable) |
| AC out 2 enabled | Switched Output-2 is enabled |
| Force Sec charge | Force charging of the second battery |
| Power off | Command to switch off the charger, inverter and open the input relays |
| Silent mode | Command to switch on/off the silent mode |

7 COMMISSIONING, DECOMMISSIONING

7.1 Commissioning



CAUTION!

Check the polarity of all wiring before commissioning: plus connected to plus (red cables), minus connected to minus (black cables).

The DIP-switches must be adjusted prior to commissioning; see chapter 6.

Follow the steps described below to switch on the Mass Combi Ultra.

- 1 Tighten all strain reliefs.
- 2 Check all wiring and connections.
- 3 Close the front cover plate of the connection compartment.
- 4 Place the DC-fuse(s) of the DC-distribution to connect the batteries to the Mass Combi Ultra.



WARNING

When placing this fuse, a spark can occur, caused by the capacitors used in the Mass Combi Ultra. This is particularly dangerous in places with insufficient ventilation, due to the gassing of the batteries an explosion can occur and avoid having flammable materials close by.

Now the Mass Combi Ultra is ready for operation.

7.2 Decommissioning

If it is necessary to put the Mass Combi Ultra out of operation, follow the instructions in order of succession as described below:

- 1 Move the Main-switch of the Mass Combi Ultra to “Off”.
- 2 Remove DC-distribution fuses and/or disconnect the batteries.
- 3 Remove AC-input fuses and/or switch off the AC-sources.
- 4 Open the connection compartment of the Mass Combi Ultra.
- 5 Check with a suitable voltage meter whether the inputs and the outputs of the Mass Combi Ultra are voltage free.
- 6 Disconnect all the wiring.

Now the Mass Combi Ultra can be demounted in a safe way.

7.3 Trouble shooting

If a failure occurs, the origin of the failure is displayed by means of the LEDs at the front of the Mass Combi, see figure 7-1.

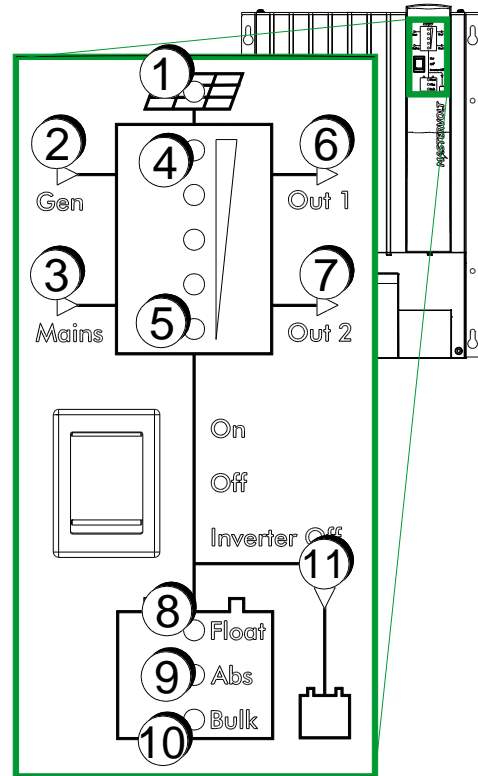

Figure 7-1: Error LEDs

The table shows the meaning of the error indications and their solutions, together with other directions. If you cannot solve a problem using this table, contact your local Mastervolt Service Centre. See www.mastervolt.com. Make sure you have the following information present if you have to contact your local Mastervolt Service Center to solve a problem:

- Article and serial number (see section 1.7).
- Software version (by means of MasterAdjust software).

7.3.1 Trouble shooting table

| illuminating LEDs | MasterBus alarm | Explanation / Possible cause | What to do |
|---|--|---|---|
| Normal operation and warnings | | | |
| None | | The Mass Combi Ultra is switched off manually. | Switch on the Mass Combi Ultra by means of the main switch. |
| (1) blinking | | Error: solar voltage or current out of range | Check Solar input, refer to input specifications in chapter 8. |
| (2) blinking slowly (2x/sec) | | Inverter is synchronizing voltage and frequency to generator AC. | Wait until the inverter is ready synchronizing. After this, it will activate the generator input. |
| (2) blinking fast (5x/sec) | MB monitoring: ACin Low quality | Error: generator input voltage or frequency out of range | Check generator voltage and frequency, refer to generator input specifications in chapter 8. |
| (3) blinking slowly (2x/sec) | | The inverter is synchronizing its voltage and frequency to mains AC | Wait until the inverter is ready synchronizing. After this, it will activate the mains input. |
| (3) blinking fast (5x/sec) | MB monitoring: ACin Low quality | Error: mains input voltage or frequency out of range | Check mains voltage and frequency, refer to generator input specifications in chapter 9. |
| (4) red | MB monitoring: Overload | Inverter in overload, inverted power exceeds 3500 W | Check the load connected and disconnect. |
| (10) red | Battery low | Battery voltage low | Stop inverting, start charging |
| (11) blinking | Error in sec charger | Internal Hardware error | Contact Mastervolt |
| (10) blinking red | | Charging a low battery | Disconnect all DC loads |
| Errors (Mass Combi Ultra shuts down) | | | |
| (4) and (10) red, (5) yellow | Overtemperature | Combi too hot. Restart when alarm is over | Check ventilation |
| (10) red, 8 and 9 yellow | Battery high | Battery voltage too high, Combi restarts when the alarm is over. | Stop charging, check battery voltage setting |
| (10) red, (8) yellow, (9) off | Temp sense error | Temperature sensor sends a wrong signal. | Check battery sensor and its cable |
| (10) red, (8) yellow, (9) off | Batt temperature | Battery hot, Combi restart when alarm is over. | |
| (4) and (10) red | System error, Sync error, Config error | Communication disturbed Configuration wrong | Check Sync cables and connectors |
| Permanent errors (manual reset required) | | | |
| (4) and (10) blinking fast red | Overload | Number of inverter overload restart attempts exceeded. | Reduce the output loads, shut off and on the Mass Combi Ultra. |
| | System error | Hardware issue | Switch off and on the Mass Combi Ultra. |
| (6) and (7) blinking fast | Install error | Installation error | Correct installation, shut off and on the Mass Combi Ultra. |

8 TECHNICAL DATA

8.1 Specifications

| Mass Combi Ultra | 12/3000-150 | 24/3500-100 | 48/3500-50 |
|---|--|---------------------------|------------------------|
| Article number | 38013000 | 38023500 | 38043500 |
| Inverter specifications | | | |
| Nominal battery voltage | 12 V | 24 V | 48 V |
| Inverter output voltage | 230 V (±2 %) (adjustable 180 – 260 V) | | |
| Frequency | 50/60 Hz (±0.005%) configurable | | |
| Continuous power @Tamb=25°C, cos phi = 1 | 3000 W | 3500 W | 3500 W |
| Continuous power@Tamb=40°C, cos phi = 1 | 3000 W | 3500 W | 3500 W |
| Max. peak load | 6000 W | 7000 W | 7000 W |
| Output waveform | True sine wave, Thd < 1 % under standard conditions | | |
| Max. efficiency | ≥ 90 % | ≥ 92 % | ≥ 93 % |
| DC input voltage range | 9.5 – 16 V | 19 – 32 V | 38 – 62 V |
| Dynamic input window battery | Programmable, current dependent switch-off levels, vary with set battery type (Gel / AGM settings below) | | |
| Switch off voltage low battery@ load ≤ 2% | 11.0 V (±2 %) | 22.0 V (±2 %) | 44.0 V (±2 %) |
| Switch off voltage low battery@ load 2-100% | 10.5 V - 9.5 V (±2 %) | 21.0 V - 19.0 V (±2 %) | 42.0 V – 38.0 V (±2 %) |
| Switch on voltage low battery | 12.0 V (±2 %) | 24.0 V (±2 %) | 48.0 V (±2 %) |
| Switch off voltage high battery | 16.0 V (±2 %) | 32.0 V (±2 %) | 64.0 V (±2 %) |
| Switch on voltage high battery | 14.5 V (±2 %) | 29.0 V (±2 %) | 60.0 V (±2 %) |
| Max. ripple on DC @ full load | < 5% RMS | < 5% RMS | < 5% RMS |
| Nominal DC current at full load | 300 A | 175 A | 90 A |
| Recommended batteries | 300 – 900 Ah* | 200 – 600 Ah* | 100 – 300 Ah* |
| No load, DC drain | | | |
| Off mode (hard switched) | 0 W | 0 W | 0 W |
| Inverter off mode (remote) | 4 W | 4 W | 4 W |
| Energy saving mode | 7 W | 7 W | 7 W |
| Normal operation mode | 26 W | 26 W | 26 W |
| Battery charger specifications | | | |
| Input voltage range | 184 – 275 V | 184 – 275 V | 184 – 275 V |
| Max AC input current | 12 A | 16 A | 16 A |
| Charge characteristic | Mastervolt 3-step+ | | |
| Battery types | AGM / Gel / MLI / Flooded / Flooded traction / Spiral / NiCad | | |
| Battery temperature sense | Input present, sensor included | | |
| Voltage sense | Only through MasterShunt, else automatic compensation | | |
| Max. charge current @Tamb=40°C | 150 A @ 14.25 V adjustable | 100 A @ 28.5 V adjustable | 50 A @ 57 V adjustable |
| Secondary output | Follows main charge (if sec. V < main V) / Fixed (power supply) | | |
| Secondary output voltage | 12 V | 12 V/24 V selectable | 12 V/24 V selectable |
| Secondary charger output current | 10 A | 10 A | 10 A |
| Transfer system specifications | | | |
| AC input 1 ("GEN") (switched) | Yes, 50 A | Yes, 50 A | Yes, 50 A |
| AC input 2 ("MAINS") (switched) | Yes, 30 A | Yes, 30 A | Yes, 30 A |
| AC Output 1 ("OUT-1") | Yes, 67 A | Yes, 67 A | Yes, 67 A |
| AC Output 2 ("OUT-2") (switched) | Yes, 50 A | Yes, 50 A | Yes, 50 A |
| AC input fuses | No | No | No |
| Transfer speed | Seamless (<1 ms) | Seamless (<1 ms) | Seamless (<1 ms) |
| Transfer voltage range (adjustable) | 184 V-275 V | 184 V-275 V | 184 V-275 V |
| Transfer frequency range (adjust.) | 35 – 68 Hz | 35 – 68 Hz | 35 – 68 Hz |
| Power sharing | Yes | Yes | Yes |
| Generator/Mains support | Yes | Yes | Yes |
| Auto-synchronize with AC input 1 / 2 | Yes | Yes | Yes |

| Mass Combi Ultra | 12/3000-150 | 24/3500-100 | 48/3500-50 |
|--|--|---|----------------|
| Paralleling/3-phase | | | |
| Parallel stacking | Yes, up to 10 standard from hardware version D | | |
| 3-phase configuration | Yes, up to 3 x 3 from hardware version D | | |
| Solar charge regulator* | | | |
| Solar input** | | | |
| Max connected solar power (Wp) | 375 Wp | 750 Wp | n/a |
| Max solar short circuit current (Isc) | 25 A | 25 A | n/a |
| Absolute max solar input voltage (Voc) (> 100V: permanent damage) | 100 V | 100 V | n/a |
| Maximum power (Pmpp) | 300 W | 600 W | n/a |
| MPPT range (Vmpp) | 15 – 80 V | 30 – 80 V | n/a |
| Maximum solar current (Impp) | 19 A | 19 A | n/a |
| PV start-up voltage | Battery voltage +2 V | Battery voltage +2 V | n/a |
| Permitted PV module configuration | 1x 36 cells 2x 36 cells in series | 2x 36 cells in series 3x 36 cells in series | n/a |
| <i>When you connect PV modules in series and/or parallel, always use PV modules of the same type and specifications.</i> | 3x 36 cells in series 1x 60 cells 2x 60 cells in series 1x 72 cells | 1x 60 cells 2x 60 cells in series 1x 72 cells | |
| Battery output | | | |
| Maximum charge current | 20 A | 20 A | n/a |
| Charge voltage range | 10 – 15 V | 10 – 30 V | n/a |
| Flat battery charge | No | No | n/a |
| General specifications | | | |
| Dimensions (HxWxD) | 472x318x178 mm | 472x318x178 mm | 472x318x178 mm |
| Weight | 15.3 kg | 15.3 kg | 15.3 kg |
| Protection degree | IP23 (vertical wall mounting) | | |
| Safety class | IEC protection class I | | |
| Grounding | Ground relay standard, includes ground stud (ABYC compliant) configurable | | |
| Operating temperature | -25 °C to 60 °C, above 40 °C derating | | |
| Overvoltage category | Gen: OVII; Mains: OVIII | | |
| Pollution degree | PDII | | |
| Relative humidity | Protected against humidity and condensing air by conformal coating, max 95% relative humidity, none condensing | | |
| Standards, approvals & listings | CE, ABYC | | |
| Options & features | | | |
| Front panel display | Yes, shows charge state, inverter power, input/output state and includes on/off/inverter off switch | | |
| Battery temperature sensor | Yes | | |
| Cooling | Maintenance free vario fans | | |
| MasterBus functionality | | | |
| MasterBus powering | Standard on, selectable | | |
| Overload protection | | | |
| Gen & Mains input | | | |
| Digital fuse | Adjustable with three preset values | | |
| Frequency monitoring | Relay disconnects when frequency is out of range | | |
| Voltage monitoring | Relay disconnects when voltage is out of range | | |
| Overvoltage protection | Non recoverable protection of the unit | | |

| Mass Combi Ultra | 12/3000-150 | 24/3500-100 | 48/3500-50 |
|-------------------------------------|---------------------|-------------|------------|
| <i>Output-1 & 2</i> | | | |
| Short circuit protection | Yes (inverter only) | | |
| Overload protection | Yes | | |
| Over temperature protection | Yes | | |
| AC backfeed protection | Yes | | |
| <i>Main & Secondary battery</i> | | | |
| Short circuit protection | Yes | | |
| Reversed polarity protection | No | | |
| High / low battery voltage | Yes | | |

* From hardware version E onwards, models 12/3000-150 and 24/3500-100 only

** The specifications in this section apply to hardware version R onwards.

Note: the following charge specifications are based on Mastervolt batteries. Specifications for a given chemistry of a different manufacturer may vary. If connecting batteries of a different manufacturer, make sure the manufacturer's recommendations are met.

| Charging specifications | Battery type | | | | |
|-------------------------|------------------------|------------------------|------------------------|------------------------|------------------------|
| | Flooded (default) | Gel / AGM / Spiral | Li-Ion (MLI) | Traction | NiCad |
| Bulk voltage | 14.25 V* | 14.25 V* | 14.25 V* | 14.55 V* | 14.50 V* |
| Max bulk time | 480 min | 480 min | 480 min | 480 min | 480 min |
| Min bulk time | 120 s | 120 s | 120 s | 120 s | 120 s |
| Start bulk time | 13.25 V* | 13.25 V* | 13.25 V* | 13.25 V* | 13.25 V* |
| Bulk ret. volt. | 12.80 V* | 12.80 V* | 13.25 V* | 12.80 V* | 13.50 V* |
| Bulk return time | 30 s | 30 s | 240 s | 30 s | 30 s |
| Abs. voltage | 14.25 V* | 14.25 V* | 14.25 V* | 14.55 V* | 14.50 V* |
| Max absorp. time | 240 min | 240 min | 240 min | 240 min | 240 min |
| Min absorp. time | 15 min | 15 min | 15 min | 15 min | 240 min |
| Return amps | 6.0 % I _{MAX} | 6.0 % I _{MAX} | 6.0 % I _{MAX} | 6.0 % I _{MAX} | 6.0 % I _{MAX} |
| Float voltage | 13.25 V* | 13.80 V* | 13.50 V* | 13.25 V* | 14,50 V* |

* For a 24 V battery charger, multiply the voltages by two.

8.2 Dimensions

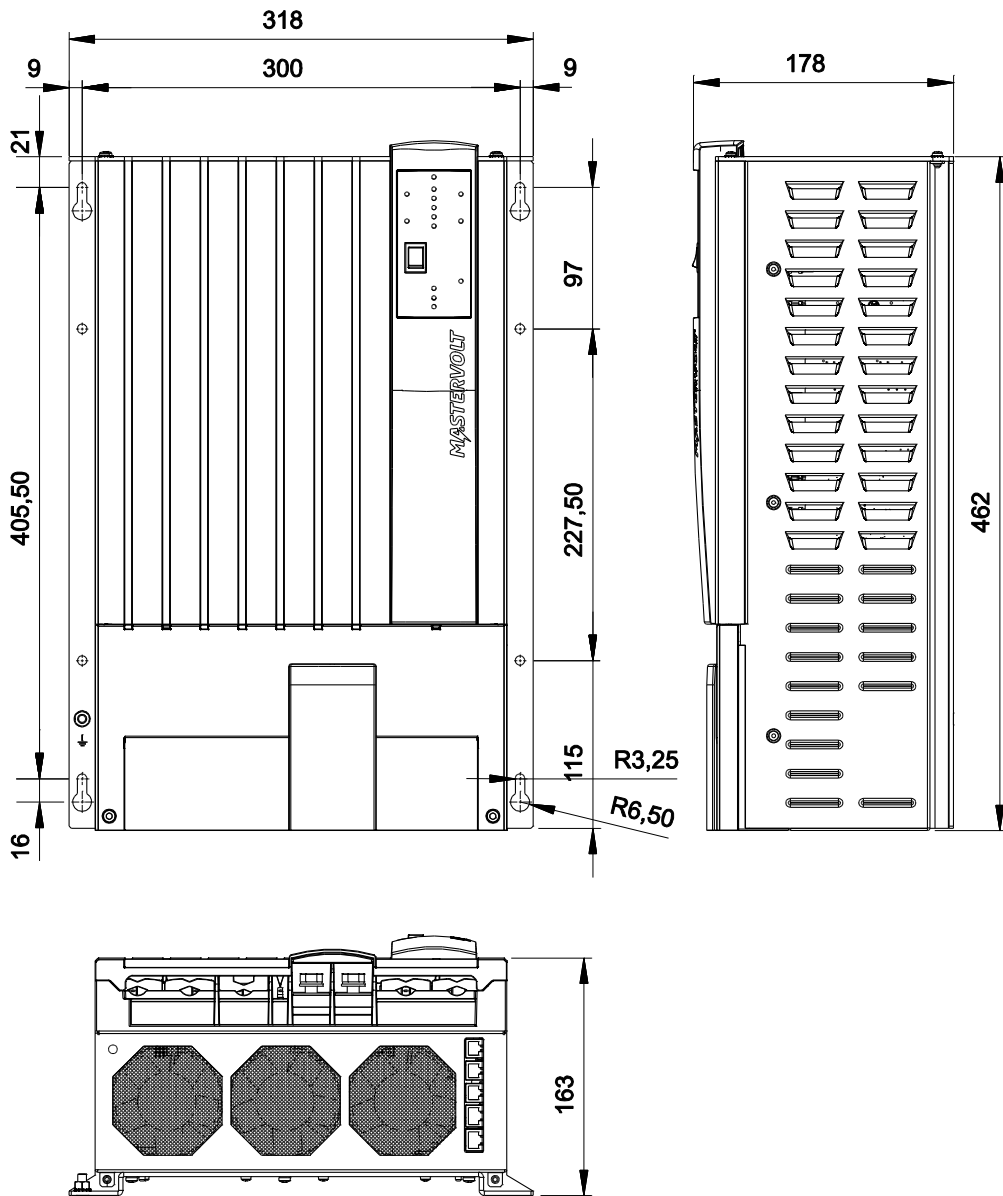

Figure 8-1: Dimensions in mm

8.3 Characteristics

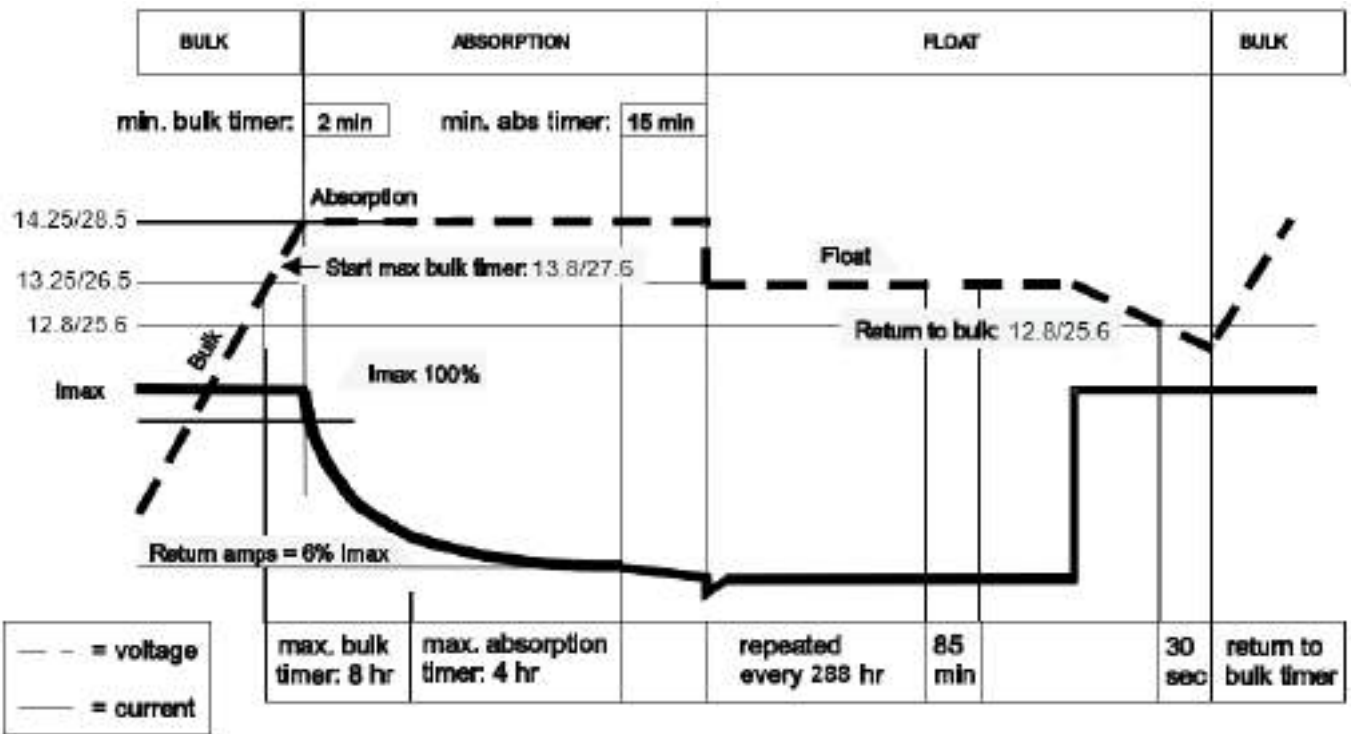

Figure 8-2: Charge characteristic of the 3-step+ charging method (at 25°C)



Europe, Middle East & Africa

Customer Service

T: +31 (0) 20 34 22 100

E: info@mastervolt.com

Technical Support

T: +31 (0) 20 34 22 100

E: ts@mastervolt.com

Location & Shipping

Mastervolt

Snijdersbergweg 93

1105 AN Amsterdam

The Netherlands

Americas & Caribbean

Customer Service

T: +1 800 307 6702, Option 1

E: orderentry@marinco.com

Technical Support

T: +1 800 307 6702, Option 2

E: tsusa@mastervolt.com

Location & Shipping

Power Products, LLC

N85 W12545 Westbrook Crossing

Menomonee Falls, Wisconsin 53051

United States

Asia Pacific

Customer Service

T: +64 9 415 7261 Option 1

E: enquiries@bepmarine.com

Technical Support

T: +64 9 415 7261 Option 3

E: technical@bepmarine.com

Location & Shipping

BEP Marine

42 Apollo Drive

Rosedale, Auckland 0632

New Zealand