

H2O ECO The Revolutionary Energy Recovery Watermaker

17- 25 Gal/Hour – 63-95 Lit/Hour



Photograph courtesy of Fountaine Pajot

The Low Power Consumption Choice

The new Patent Pending Energy Recovery Device H2O ECO is engineered for boaters with limited power options. Featuring automatic operation, it is ideal for Catamarans and sail boats.

Key Features:

- Compact robust design
- Smooth operation
- Small footprint



Contact Information:

Parker Hannifin Corporation
Water Purification
2630 E. El Presidio Street
Carson, CA 90810

phone 310 608 5600
fax 310 608 5692

waterpurification@parker.com

Website:

www.parker.com/waterpurification

Sales:

waterpurification@parker.com

Tech Support:

watertech@parker.com

Key Features & Benefits:

- Energy Recovery Device
- Recovers up to 14.5%
of power on all models
- AC and DC Models Available
- Fully Automatic Operation
- Compact Configuration
- Manual Fresh Water Flush
- External Booster Pump

Optional Accessories:

- B561080001 pH Neutralizer
- B611000004 Remote Control
- B521220002 Charcoal Filter
- B5262000CV UV Sterilizer
- 61012116 External Strainer
- B598000008 Automatic
Fresh Water Flush
- 61012124 Installation Kit



ENGINEERING YOUR SUCCESS.

Specifications

Part Number	Voltage (DC/AC)	Capacity (GPD)	LPH	DC Power (Watts)	AC (NOA)	Weight
A012C-111	12	400	63	240		120lbs / 54kg
A012C-121	24	400	63	240		120lbs / 54kg
A012C-211	12	600	95	437		125lbs / 57kg
A012C-221	24	600	95	437		125lbs / 57kg
A012C-311	110/50 - 60/1	400	63		5.8	120lbs / 54kg
A012C-321	220/50 - 60/1	400	63		2.9	120lbs / 54kg
A012C-411	110/50 - 60/1	600	95		9	125lbs / 57kg
A012C-421	220/50 - 60/1	600	95		4.5	125lbs / 57kg

NOA = Normal Operation Amps

Dimensions

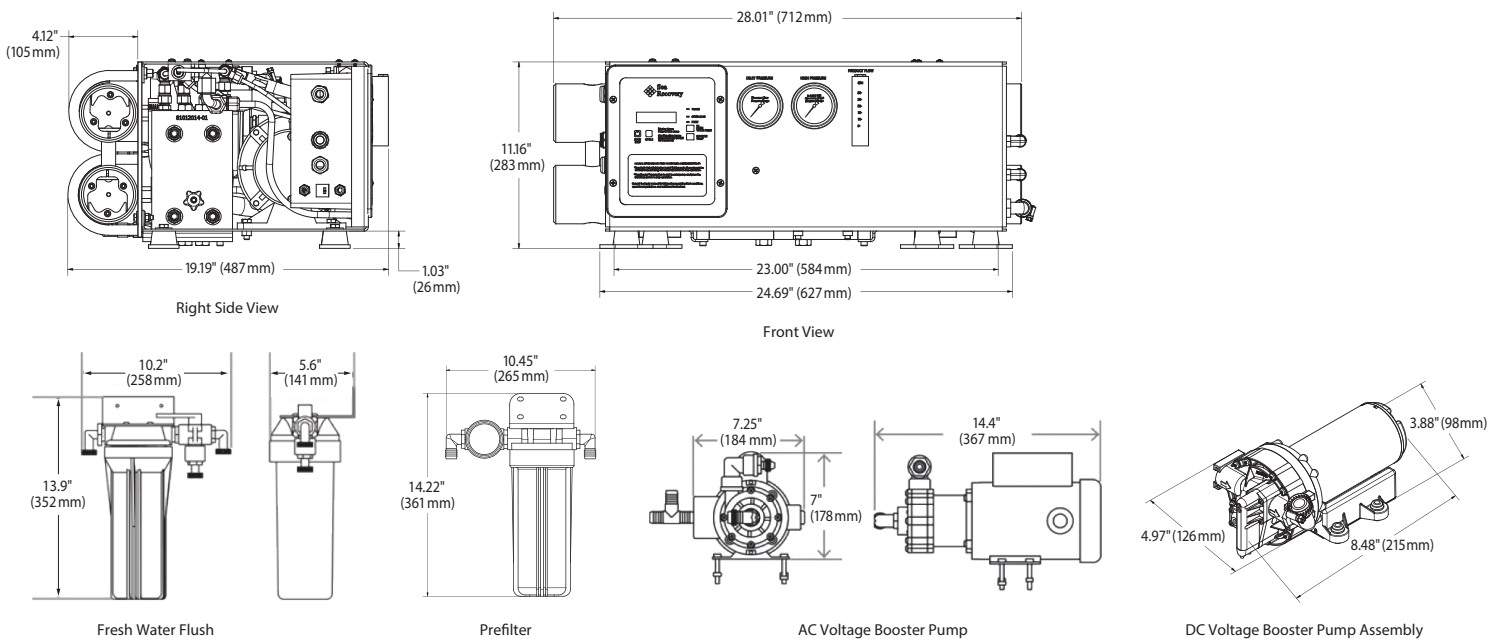

Duration Maintenance kits

Product Family	Initial Load Out	3 Months (200 hrs.)	6 Months (500 hrs.)	12 Months (1000 hrs.)	24 Months (2000 hrs.)
H2O ECO (Standard Prefilters)	61012096	61012097	61012098	61012099	61012100

To maintain peak performance, always use genuine Parker Village Marine replacement parts. We reserve the right to change our specifications or standards without notice.

WARNING: This product can expose you to chemicals including Di(2-ethylhexyl) phthalate (DEHP), which is known to the state of California to cause cancer and birth defects or other reproductive harm. For more information go to www.P65Warnings.ca.gov.

