

BTH Series

REV 001B



HYDRAULIC THRUSTERS

BTH 18585 - 185105

BTH 250150 - 250220

BTH 300240 - 300300 - 300400

BTH 386420 - 386455 - 386455HD - 386550HD - 386580 HD

BTH 5131000

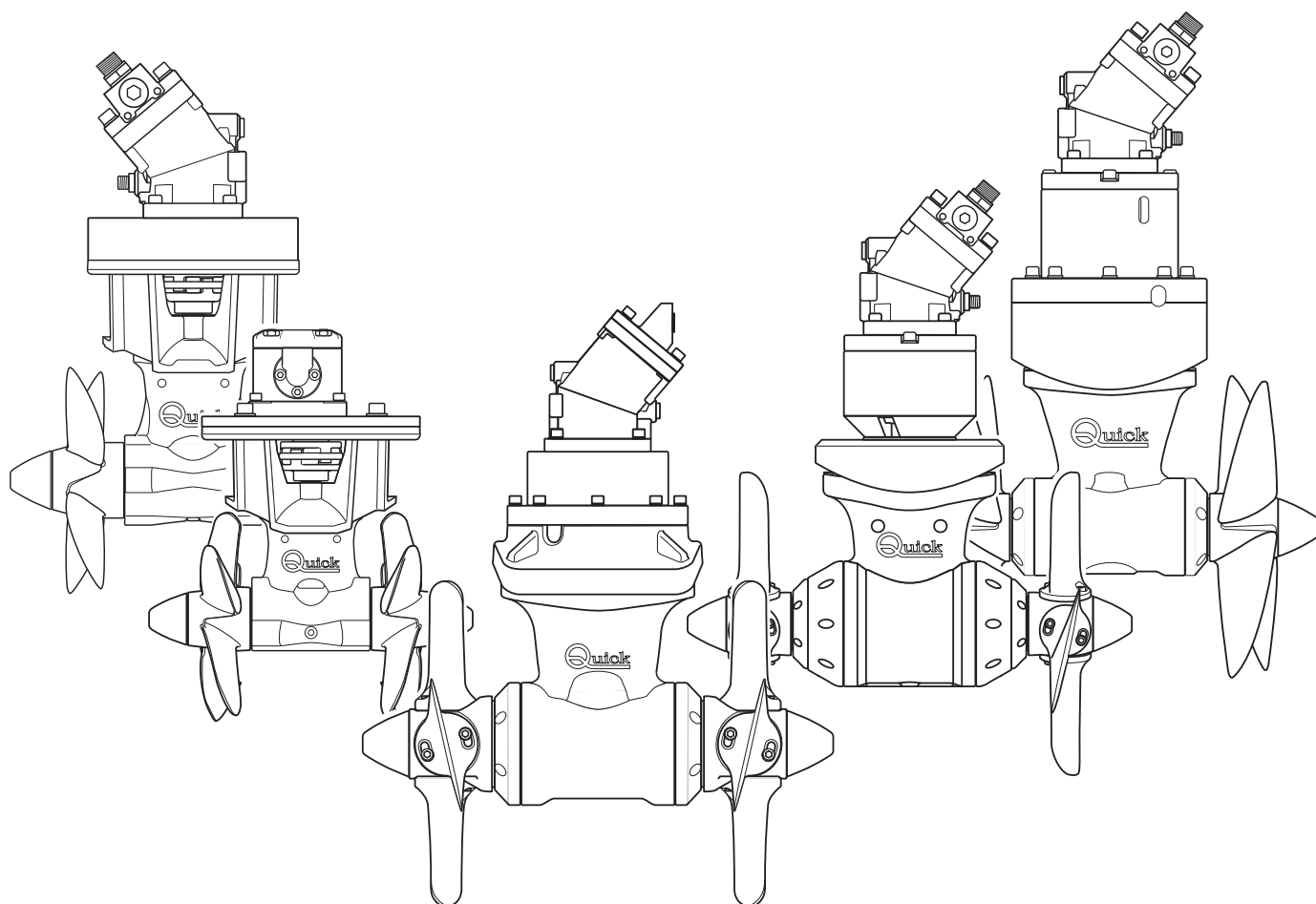

***EN - INSTALLATION AND USER'S MANUAL**

*Other languages available by scanning the QR code on the back of this manual or on the label on the product.

Quick[®]
Nautical Equipment

1 - Information about the product	5
1.0 - Technical Data	5
2 - Supply and equipment	7
2.0 - Standard supply and material included in the package	7
2.1 - Tools required for installation	7
2.2 - Recommended Quick® accessories not included	7
3 - Introduction	8
3.0 - Important notes	8
3.1 - Precautions	8
3.2 - Precautions for the installer	8
3.3 - Installation requirements	8
4 - Installation	9
4.0 - Propellers	9
4.1 - Tunnel	10
4.2 - Thruster	11
4.3 - BTH 185/250/300 Gearleg and motor support flange	12
4.4 - BTH 386 Gearleg and motor support flange	13
4.5 - BTH 513 Gearleg and motor support flange	13
4.6 - BTH 386 Rilsan hose and oil tank	14
4.7 - BTH 513 Rilsan hose and oil tank	14
4.8 - Positioning of fitting and oil tank	15
4.9 - BTH 386 motor/coupling assembly	16
4.10 - BTH 386HD motor/coupling assembly	17
4.11 - BTH 513 motor/coupling assembly	18
4.12 - Propeller assembly	19
5 - Wiring diagram	20
6 - Cautions & Use	20
6.0 - Use	20
6.1 - Important cautions	20
7 - System characteristics	21
8 - Maintenance	22
9 - Product disposal	23
10 - Spare parts	24
10.0 - BTH 185	24
10.1 - BTH 250	25
10.2 - BTH 300	26
10.3 - BTH 386	27
10.4 - BTH 386 HD	28
10.5 - BTH 513	29
11 - Dimensions	30



READ THIS INSTRUCTION MANUAL CAREFULLY BEFORE USING THE PRODUCT. IF IN DOUBT, CONTACT YOUR QUICK® DEALER.



QUICK® RESERVES THE RIGHT TO MODIFY THE TECHNICAL CHARACTERISTICS OF THE EQUIPMENT AND THE CONTENTS OF THIS MANUAL WITHOUT PRIOR NOTICE. IN CASE OF DISCORDANCE OR ERRORS IN TRANSLATION BETWEEN THE TRANSLATED VERSION AND THE ORIGINAL TEXT IN THE ITALIAN LANGUAGE, REFERENCE WILL BE MADE TO THE ITALIAN TEXT.

The efficiency of the hydraulic motor is conditioned by the hydraulic energy supplied by the hydraulic power unit to which it is connected. In particular, it will be influenced by the speed of the main motor, if this is the one supplying the pump, and/or by other hydraulic devices supplied at the same time.

1.0 - Technical Data

MODELS	BTH 185-85	BTH 185-105
No. of Propellers	2 Counter rotating	
Tunnel Ø	185 mm (7" 9/32)	
Motor type	Reversible gear type	
Displacement	4.5 cc (0.3 in3)	6.4 cc (0.4 in3)
Door flanges (A and B) (1)	G 1/2"	G 1/2"
Drainage hole (C) (1)	G 1/4"	
Tunnel thickness limit values	min. 4.5 mm - max 6.5 mm (min. 11/64" - max 1/4")	
Weight	8.8 kg (19.4 lb)	8.9 kg (19.6 lb)
ADJUSTMENT VALUES (Recommended by Quick®)		
Flow rate	17 l/min	28 l/min
Pressure	250 bar	190 bar
Hydraulic power input	6.4 kW	8 kW
Thrust	85 kgf (187.4 lbf)	105 kgf (231.5 lbf)

MODELS	BTH 250-150	BTH250-220
No. of Propellers	2 Counter rotating	
Tunnel Ø	250 mm (7" 9/32)	
Motor type	Reversible gear type	
Displacement	9.6 cc (0.6 in3)	14.1 cc (0.9 in3)
Door flanges (A and B) (1)	G 3/4"	
Drainage hole (C) (1)	G 1/4"	
Tunnel thickness limit values	min. 6.5 mm - max 11 mm (min. 1/4" - max 7/16")	
Weight	17.1 kg (37.7 lb)	17.3 kg (38.1 lb)
ADJUSTMENT VALUES (Recommended by Quick®)		
Flow rate	25.5 l/min	41.5 l/min
Pressure	240 bar	180 bar
Hydraulic power input	9.2 kW	11.2 kW
Thrust	150 kgf (187.4 lbf)	220 kgf (231.5 lbf)



MODELS	BTH 300-240	BTH 300-300	BTH 300-400
No. of Propellers	2 Counter rotating		2 Counter rotating (NIBRAL)
Tunnel Ø	300 mm (11" 13/16)		
Motor type	Reversible gear type		Pistons
Displacement	17.9 cc (1.1 in ³)	22 cc (1.3 in ³)	32 cc (1.9 in ³)
Door flanges (A and B) (1)	G 3/4"		
Drainage hole (C) (1)	G 1/4"	G 3/8"	
Tunnel thickness limit values	min. 9.5 mm - max 13.5 mm (min. 3/8" - max 17/32")		
Weight	24.2 kg (53.3 lb)	27.6 kg (60.8 lb)	40.8 kg (90.0 lb)
ADJUSTMENT VALUES (Recommended by Quick®)			
Flow rate	42.5 l/min	60.0 l/min	100.0 l/min
Pressure	220 bar	225 bar	230 bar
Hydraulic power input	15.5 kW	20.0 kW	24.0 kW
Thrust	240 kgf (529.1 lbf)	300 kgf (661.4 lbf)	400 Kgf (881.8 lbf)

MODELS	BTH 386-455HD	BTH 386-550HD	BTH 386-580HD
No. of Propellers	2 Counter rotating (NIBRAL)	2 Counter rotating	2 Counter rotating (NIBRAL)
Tunnel Ø	386 mm (15" 13/64)		
Motor type	Pistons		
Displacement	41 cc (2.5 in ³)	55 cc (3.1 in ³)	
Door flanges (A and B) (1)	G 3/4"	G 1"	G 1"
Drainage hole (C) (1)	G 3/8"	G 1/2"	
Tunnel thickness limit values	min. 8 mm - max 15 mm (min. 5/16" - max 19/32")		
Weight	85.0 kg (187.4 lb)	75.0 kg (165.3 lb)	90.0 kg (198.4 lb)
ADJUSTMENT VALUES (Recommended by Quick®)			
Flow rate	90.0 l/min		110.0 l/min
Pressure	250 bar		
Hydraulic power input	34.0 kW	41.0 kW	
Thrust	455 kgf (1003.1 lbf)	550 kgf (1212.5 lbf)	580 kgf (1278.7 lbf)

MODELS	BTH 386-420	BTH 386-455	BTH 513-1000
No. of Propellers	2 Counter rotating	2 Counter rotating (NIBRAL)	2 Counter rotating (NIBRAL)
Tunnel Ø	386 mm (15" 13/64)		513 mm (1130 lb)
Motor type	Pistons		
Displacement	41 cc (2.5 in ³)		90 cc (5.5 in ³)
Door flanges (A and B) (1)	G 3/4"		G 1"
Drainage hole (C) (1)	G 3/8"		G 1/2"
Tunnel thickness limit values	min. 8 mm - max 15 mm (min. 5/16" - max 19/32")		min. 12 mm - max 22 mm (min. 5/16" - max 33/64")
Weight	60.0 kg (132.3 lb)	70.0 kg (154.3 lb)	182.0 kg (401.2 lb)
ADJUSTMENT VALUES (Recommended by Quick®)			
Flow rate	90.0 l/min		140.0 l/min
Pressure	250 bar		
Hydraulic power input	34.0 kW		60 kW
Thrust	420 kgf (529.1 lbf)	455 kgf (661.4 lbf)	1000 kgf (881.8 lbf)



2.0 - Standard supply and material included in the package

- Hydraulic thruster
- Drilling template
- Installation and use manual
- Conditions of warranty

2.1 - Tools required for installation

- BTH 185**
 - Drill and drill bits Ø 9 mm (3/8")
 - Hollow mill Ø 32 mm (1" 1/4)
 - Male hex.wrenches: 5 mm, 6 mm, 8 mm and 10 mm
 - Fork or polygonal wrench: 19 mm
- BTH 250**
 - Drill and drill bits Ø 11 mm (7/16")
 - Hollow mill Ø 46 mm (1" 13/16)
 - Male hex.wrenches: 4 mm, 5 mm, 8 mm and 10mm
 - Fork or polygonal wrench: 24 mm
- BTH 300**
 - Drill and drill bits Ø 15 mm (19/32")
 - Hollow mill Ø 53 mm (2" 3/32)
 - Male hex.wrenches: 4 mm, 5 mm, 8 mm and 12 mm
 - Fork wrench: 27 mm
- BTH 386**
 - B00 Drill and drill bits Ø 18 mm (19/32")
 - C00 Drill and drill bits Ø 16 mm (5/8")
 - B00 Hollow mill Ø 82 mm (3" 7/32)
 - C00 Hollow mill Ø 120 mm (4" 23/32)
 - Male hex.wrenches: 5 mm, 8 mm and 14 mm
 - Fork wrench: 27 mm
- BTH 513**
 - Drill and drill bits Ø 18 mm (45/64")
 - Hollow mill Ø 140 mm (5" 33/64)
 - Male hex.wrenches: 5 mm, 8 mm and 14 mm
 - Fork or polygonal wrench: 32 mm

2.2 - Recommended Quick® accessories not included

- Controls for TCD 2022 • TCD 2042 • TCD 2044 • TCD 2062 thrusters
- Proportional controls for PCS TJ1 • PCS TJ2 thrusters
- Monitor for PCS DTW system
- Control for thrusters with proportional system AJ1 Thruster Command Proportional controls for PAJ 1T AMC
- PAJ 2T AMC thrusters
- Central unit for AMC system



BEFORE USING THE PRODUCT, PLEASE READ THIS USER'S MANUAL CAREFULLY. IF IN DOUBT, PLEASE CONSULT YOUR QUICK® DEALER.

3.0 - Important notes

This manual features Warning and/or Caution symbols that are important for safety. Please follow the instructions provided.



Warning symbol for dangerous situations.



Caution symbol to prevent direct or indirect damage to the product.

This manual provides boat manufacturers and nautical equipment installers with instructions on how to assemble the specified Quick® product and operate it correctly.

3.1 - Precautions



Quick® thrusters have been designed and constructed only for nautical use.

- Do not use these products for any other type of operation.
- Quick® shall not be held liable for direct or indirect damage caused by improper use of the product.
- The product is not designed to support loads generated in particular atmospheric conditions (storms).
- Operate the product from a position where it is possible to supervise the work area.
- Always deactivate the windlass when not being used.
- For improved safety, we recommend installing at least two controls to operate the product in case one is damaged.
- The installer shall bear full responsibility for any problems caused by defective installation of the tunnel.
- This equipment is not intended for use by people (including children) with reduced physical, sensory or mental capabilities.
- Do not install the hydraulic motor near easily inflammable objects.

3.2- Precautions for the installer



CARRY OUT THE INSTALLATION IN GOOD LIGHTING CONDITIONS.

It is advisable to wear suitable clothing and personal protective equipment (PPE).

The product is not suitable for installation in potentially explosive environments and/or atmospheres. Installation and subsequent inspection or repair work must only be carried out by qualified personnel.



CARRY OUT INSTALLATION/MAINTENANCE WORK MAKING SURE THAT THE PRODUCT IS DISCONNECTED FROM THE ELECTRICAL SYSTEM.

Quick® accepts no responsibility for inadequate connection of users to the electrical system and inadequate safety of the electrical system.

3.3 - Installation requirements

We recommend you entrust preparation and positioning of the tunnel in the hull to a skilled professional.

These are generic instructions and do not give details of the preparatory operations for installing the thruster, since this is the competence of the boatyard. The installer shall bear full responsibility for any problems caused by defective installation.

Although all the components and mechanical moving parts are of high quality, the correct installation of the driving unit is an essential basis for the safe and effective use of the boat as well as the driving unit itself.

The installation of such a unit is an operation that requires experience as well as technical skills. It is recommended that the installation be carried out by competent personnel and that the manufacturer or naval architects be consulted to fully assess the scope of the work.



4.0 - Propellers

FIG. 1

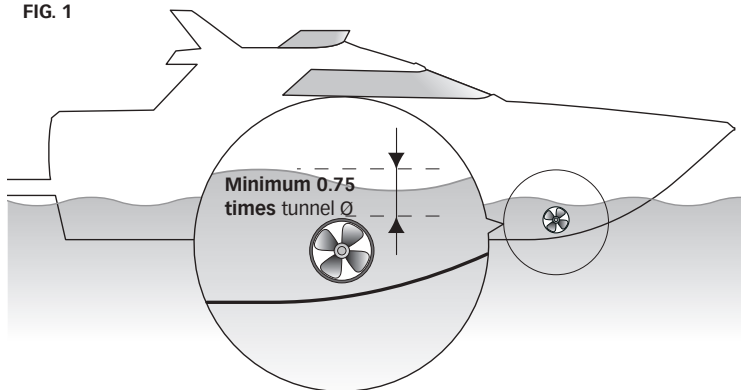

The position of the tunnel will depend on the interior and exterior shape of the boat's bow.

• FIG. 1 In order to avoid cavitation in the propeller, the tunnel should be placed as deep as possible. The optimum tunnel position will be at least 0.75 times the diameter of the tunnel from the waterline.

FIG. 2

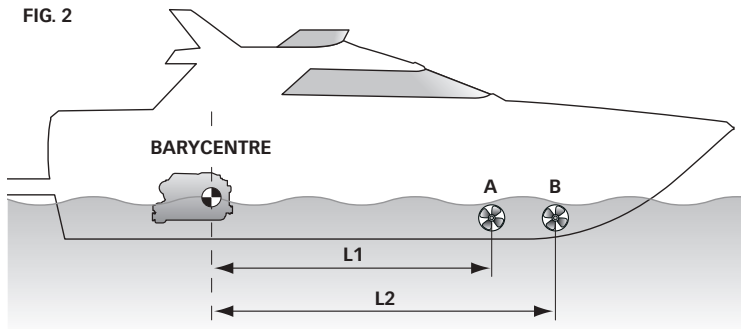

• FIG. 2 The lever effect in the boat is proportional to the increase of the distance (L1 and L2) between the barycentre and the position of the tunnel A and B.

FIG. 3

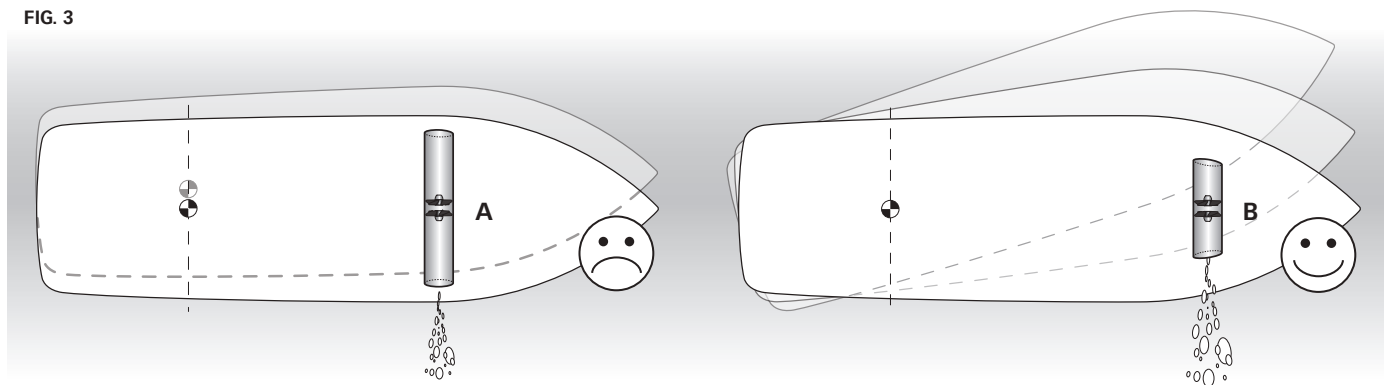

• FIG. 3 For greater lever effect prefer position B.

FIG. 4

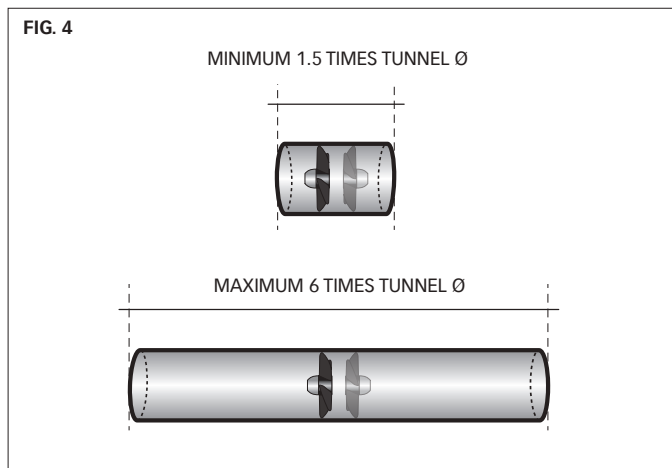

An increase in the length of the tunnel increases the effect of the loss of charge, decreasing the nominal driving force.

• FIG. 4 For a proper use of the thruster, we recommend a length equal to 1.5 to 4 times the tunnel diameter. To limit losing charge, a ratio of up to 6 times the diameter can be tolerated.

4.1 - Tunnel

- The rounded ends of the tunnel limit the creation of turbulence and cavitation, improving performance of the propeller thrust and reducing noise levels to a minimum.

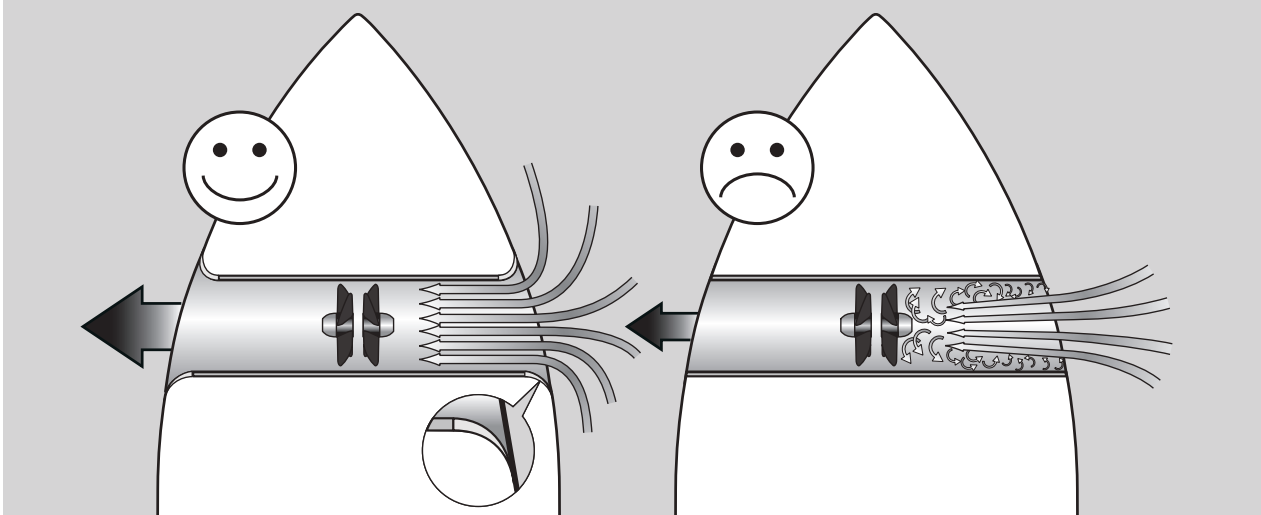

- The force produced by the flow of the water when the boat is moving produces resistance on the rear face of the tunnel, which is an area exposed frontally to the water flow. To limit this phenomenon, prepare an indentation in the rear part of the tunnel. The indentation will depend on the shape of the hull. Otherwise, create a deflector on the front part of the tunnel.

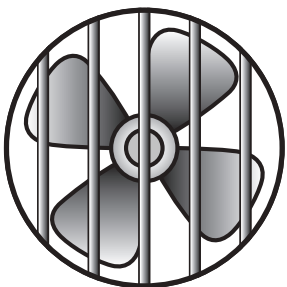
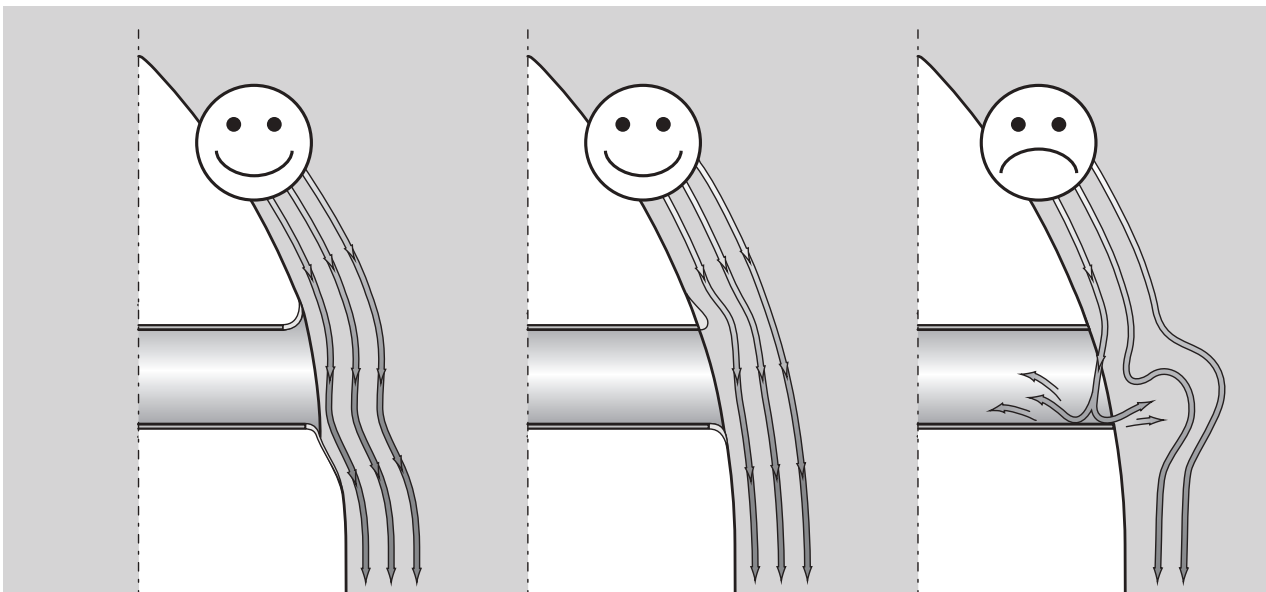

- If the tunnel is near the waterline, it is advisable to fit a grating at the end of the tube. The grating must have as large a vertical mesh as possible to avoid contrasting the propeller thrust. The vertical mesh prevents the entry of most of the floating objects.



4.2 - Thruster

• **FIG. 1** The thruster can be installed at any angle within 90° from the vertical. The hydraulic motor does not require supports or stands.

FIG. 1

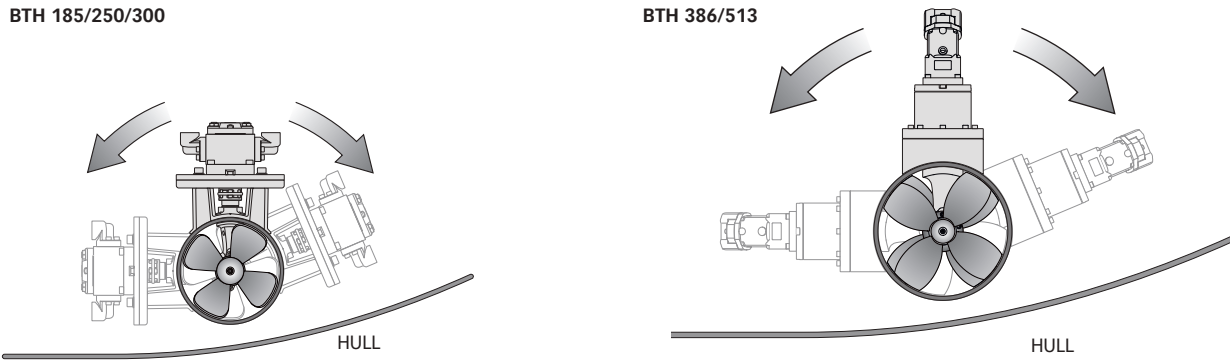

- **FIG. 2** To position the thruster in the tube, find the half-way point.
- **FIG. 3** Use the flange to mark the centre of the holes on the tube.

FIG. 2

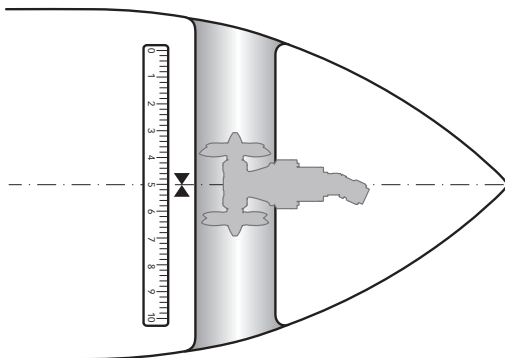
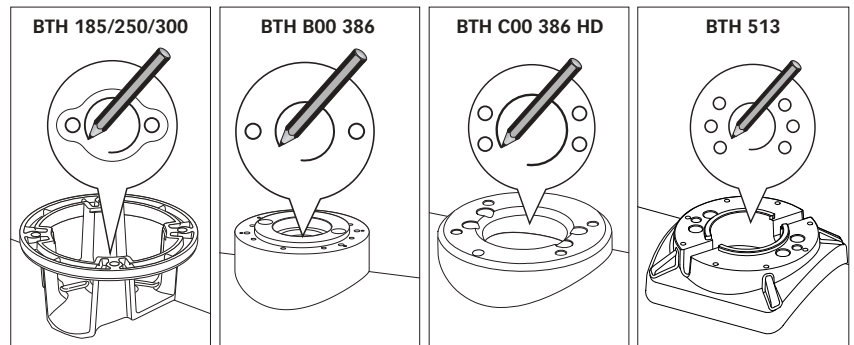
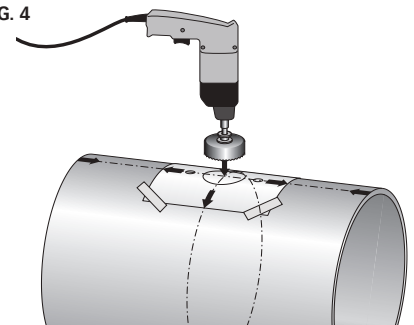

FIG. 3



• **FIG. 4** Fix the drilling template on the reference points, making sure they are aligned with precision at the half-way point of the tube.

FIG. 4



 N.B. All holes must be exactly aligned with the half-way point of the tunnel, since tolerance between propeller and tunnel is minimal.

Take care that there are no resin residues in the contact area between flange and tube; this could cause misalignment. Any resin residues and any other hindrance to correct contact must be removed with sandpaper.

• **FIG. 5A / FIG. 5B**

Insert two O-rings into the special seats inside the flange.

FIG. 5A

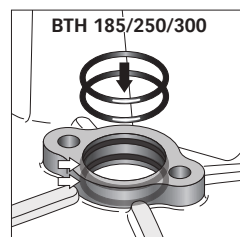
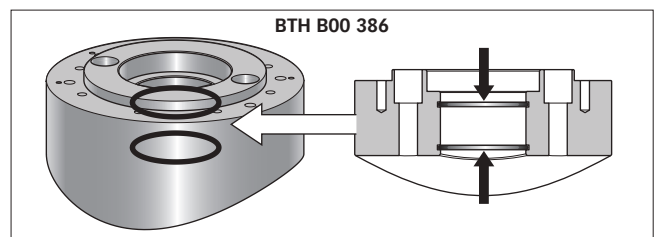

FIG. 5B



4.3 - BTH 185/250/300 Gearleg and motor support flange

• **FIG. 1** Fit the gearleg with the special seal gasket. For further protection against the entry of water, apply silicone for nautical use around the point of contact between flange and tube. Fasten everything with the flange using the special screws and washers.

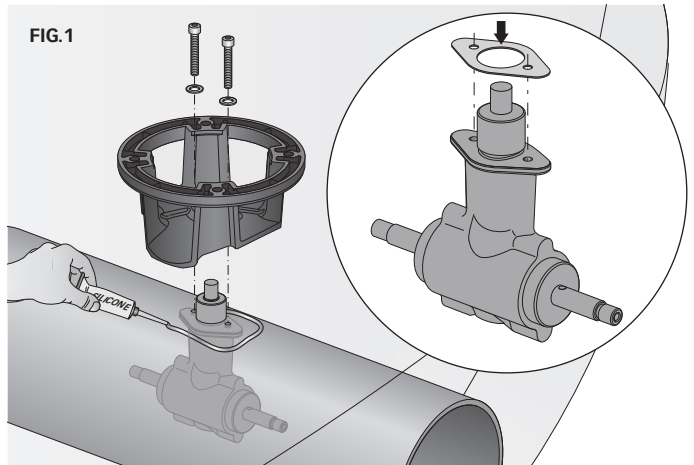
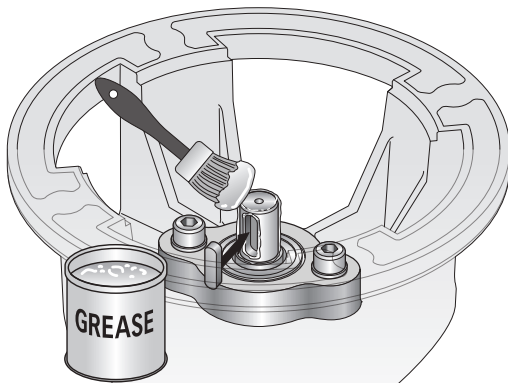
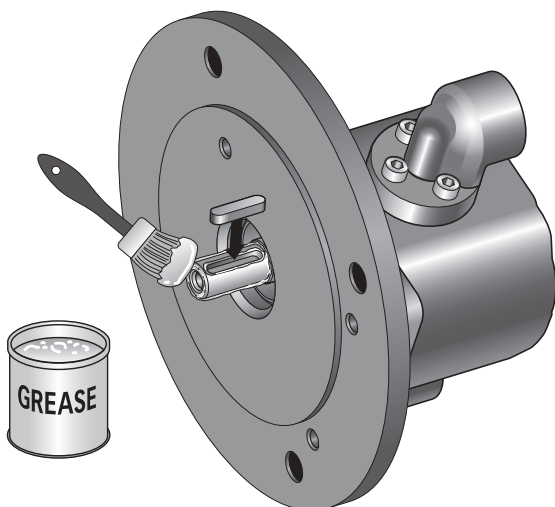

FIG.2



• **FIG. 2** Grease the terminal part of the gearleg shaft; fit the small key into its seat.

FIG.4



• **FIG. 4** Grease the terminal part of the drive shaft; fit the key into its seat.

FIG.3

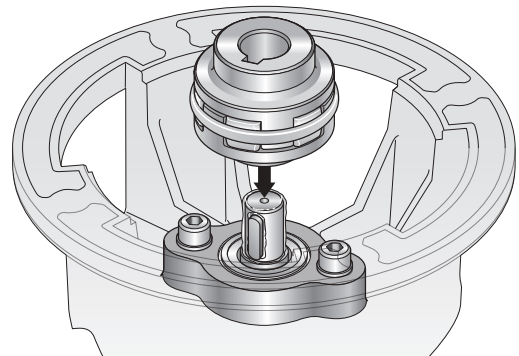

• **FIG. 3** Insert the elastic coupling in the terminal part of the gearleg shaft.

FIG.5

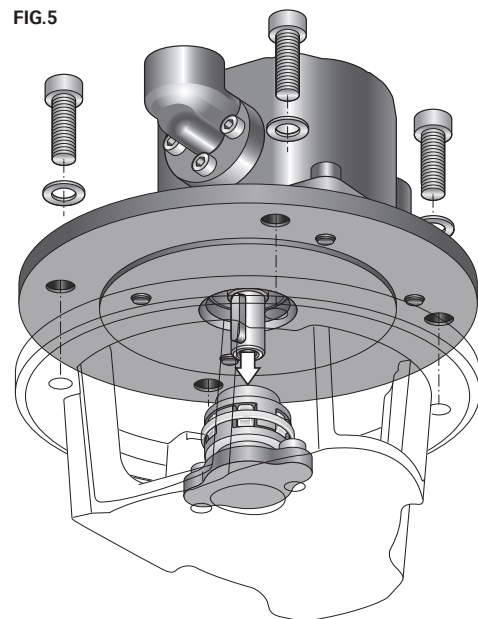

• **FIG. 5** Insert the motor onto the elastic coupling; secure it with the 4 screws and washers supplied.



4.4 - BTH 386 Gearleg and motor support flange

- **FIG. 1** Fit the gearleg with the special seal gasket. For further protection against the entry of water, apply silicone for nautical use around the point of contact between flange and tube. Fasten the flange using the special screws and washers: 2 screws for gearbox B00 - 4 screws for gearbox C00 HD.
- **FIG. 2** Grease the terminal part of the gearleg shaft; fit the small key into its seat.

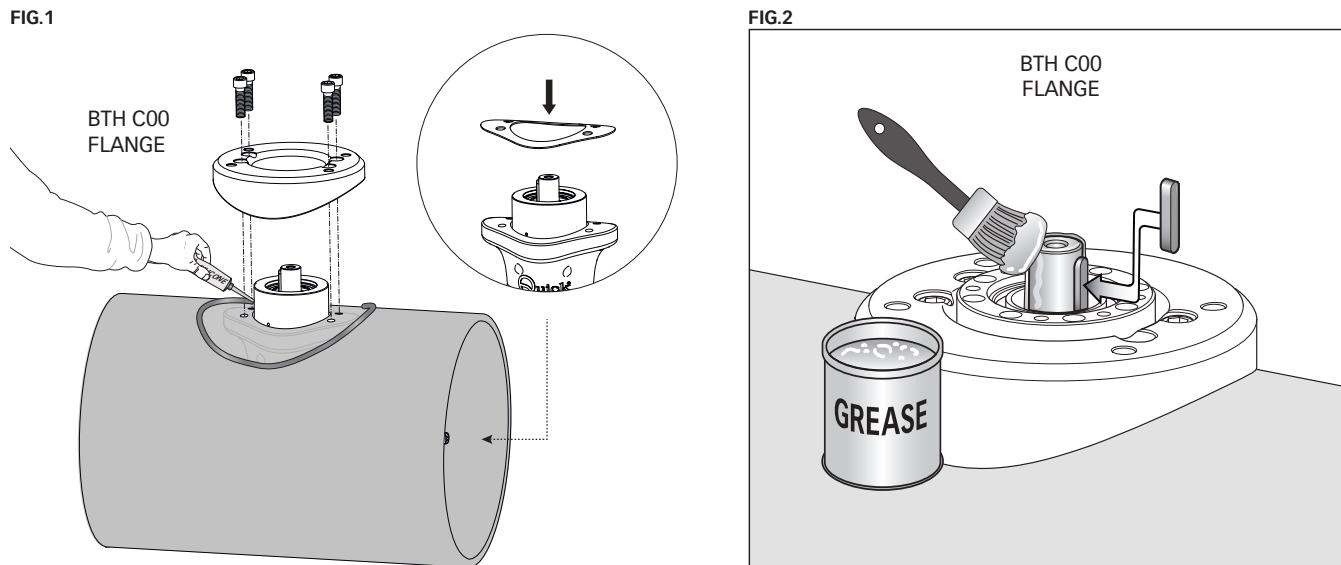

4.5 - BTH 513 Gearleg and motor support flange

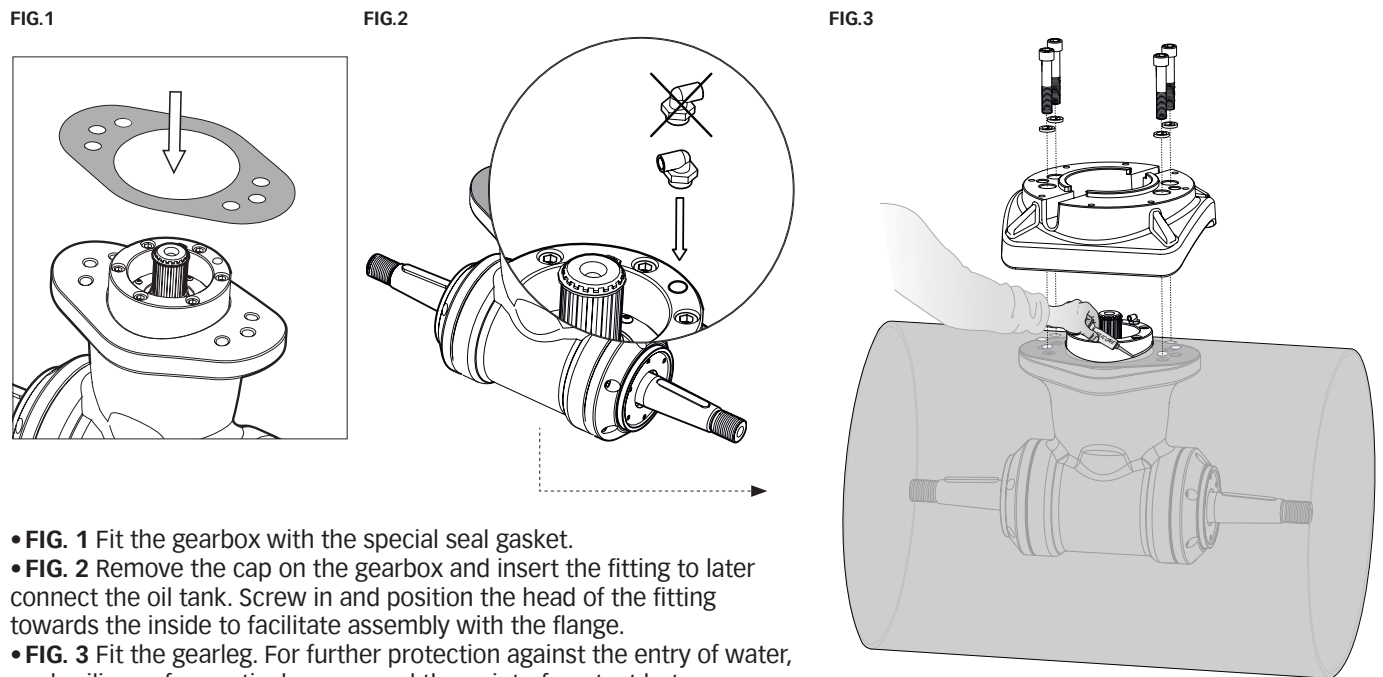

- **FIG. 1** Fit the gearbox with the special seal gasket.
- **FIG. 2** Remove the cap on the gearbox and insert the fitting to later connect the oil tank. Screw in and position the head of the fitting towards the inside to facilitate assembly with the flange.
- **FIG. 3** Fit the gearleg. For further protection against the entry of water, apply silicone for nautical use around the point of contact between flange and tube. Fasten the flange using the special screws.

4.6 - BTH 386 Rilsan hose and oil tank

- FIG. 1 Remove screw and gasket
- FIG. 2 Tighten the fitting provided
- FIG. 3 Insert the Rilsan hose onto the fitting and the tank

BTH 386 B00

FIG. 1

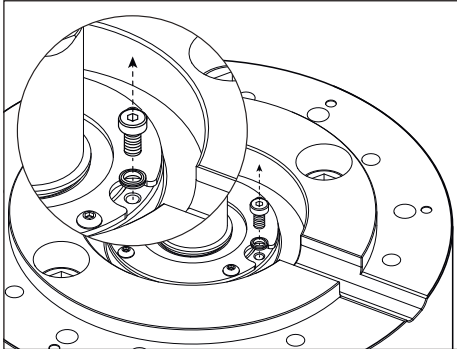

FIG. 2

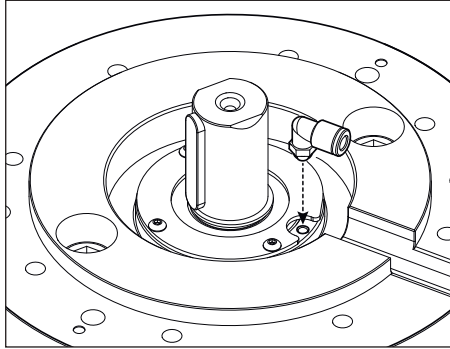
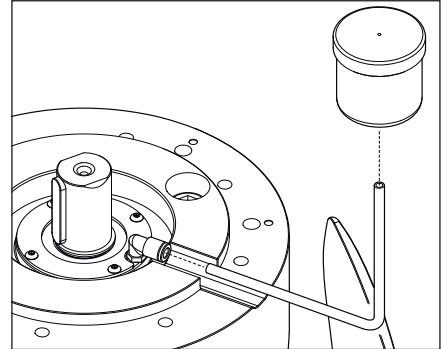

FIG. 3



BTH 386HD C00

FIG. 1

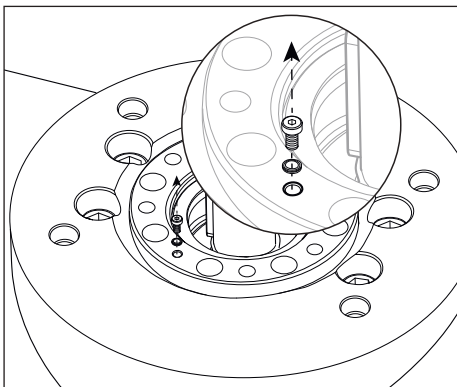

FIG. 2

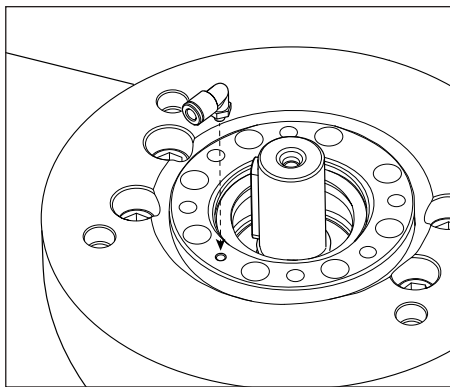
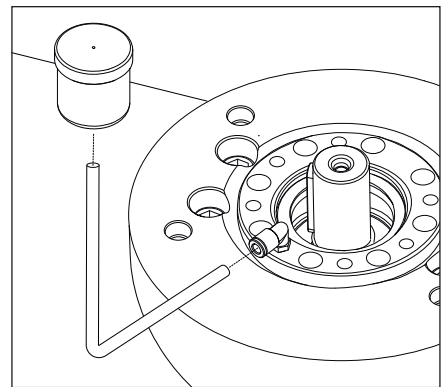
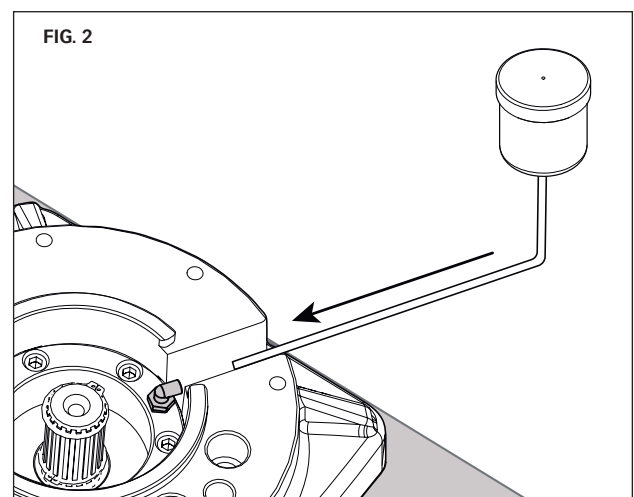
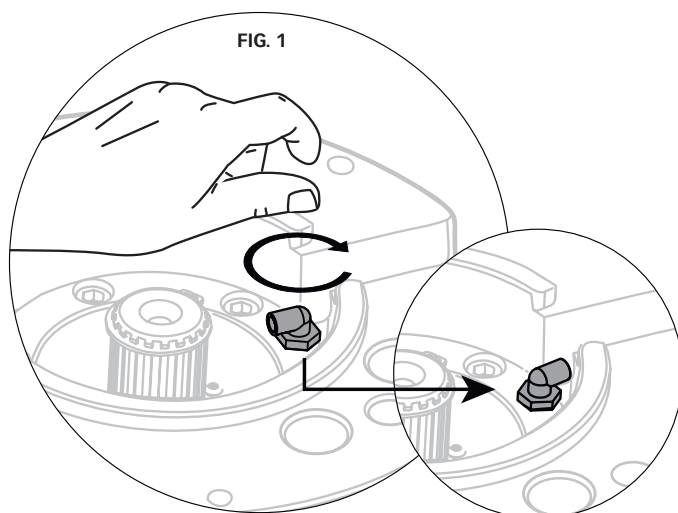

FIG. 3



4.7 - BTH 513 Rilsan hose and oil tank

- FIG. 1 After fastening the flange, turn the fitting clockwise and align it with the flange recess.
- FIG. 2 Insert the Rilsan hose with oil tank into the fitting.





4.8 - Positioning of fitting and oil tank

- Install the oil tank (1) above the waterline by at least 20% of the distance between the waterline and the centre of the tunnel (distance d). This is to ensure sufficient oil overpressure.
- Fill the oil tank with gear oil type GL-5.

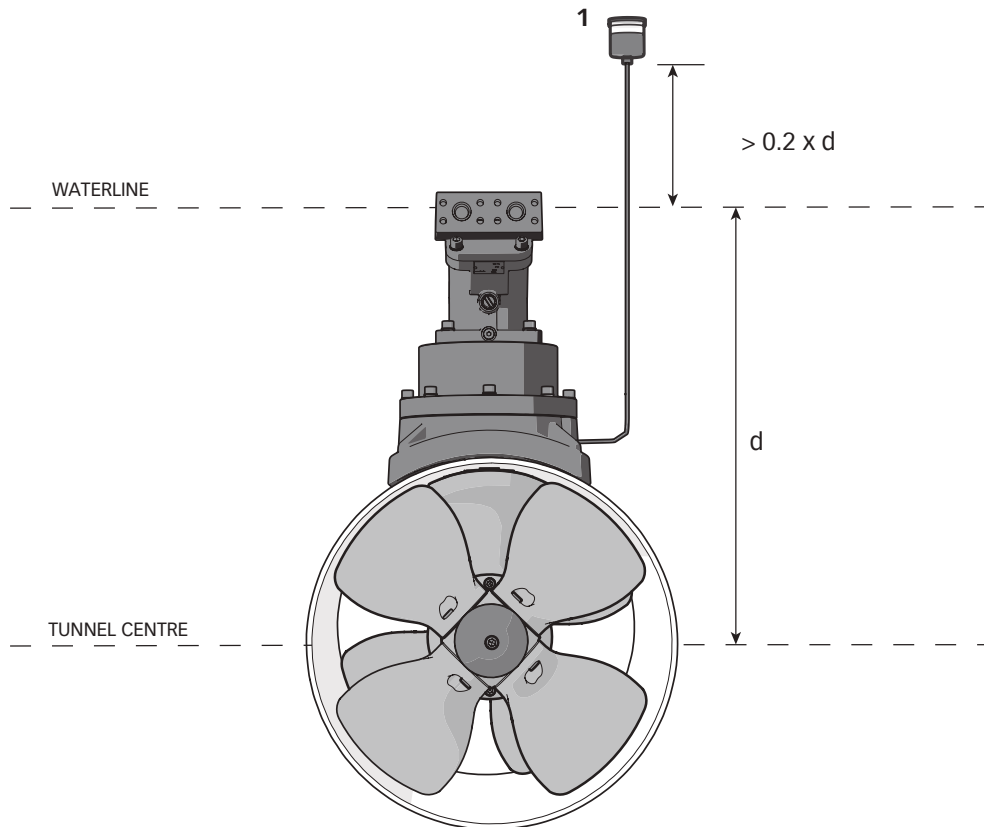

**POSITION THE TUBE CORRECTLY IN ORDER TO AVOID A "SIPHON" EFFECT.
THE TANK MUST ALWAYS BE IN A VERTICAL POSITION.**

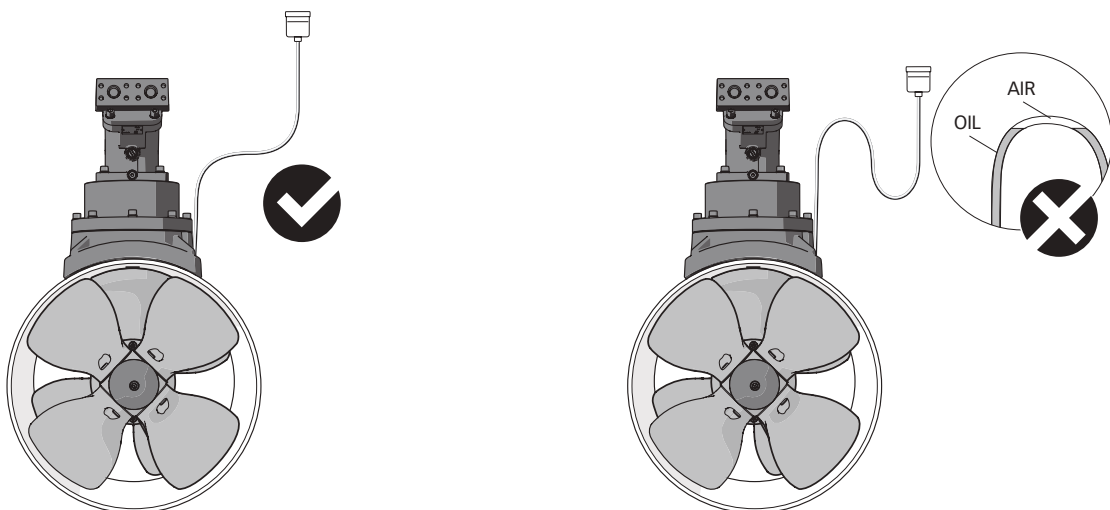

4.9 - BTH 386 motor/coupling assembly

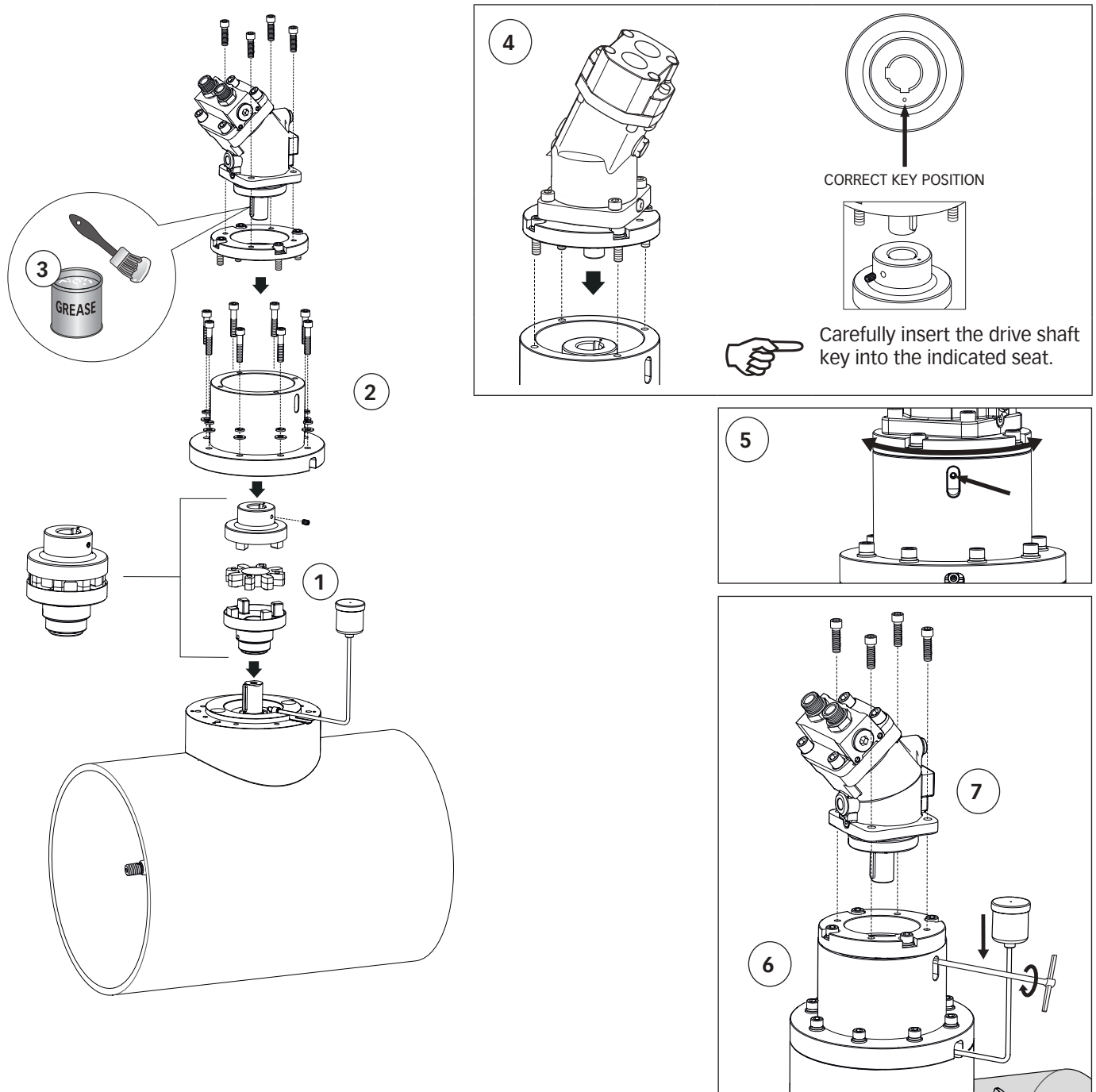
**Procedure:**

1. Insert the elastic coupling in the terminal part of the gearleg shaft.
2. Secure the motor flange with the supplied screws.
3. Grease the terminal part of the drive shaft
4. Place the motor on the elastic coupling.
5. Rotate the motor to align the coupling screw.
6. Tighten the screw of the coupling, holding it towards the gearbox.
7. Turn the motor to the desired position and secure it with the screws.



4.10 - BTH 386HD motor/coupling assembly

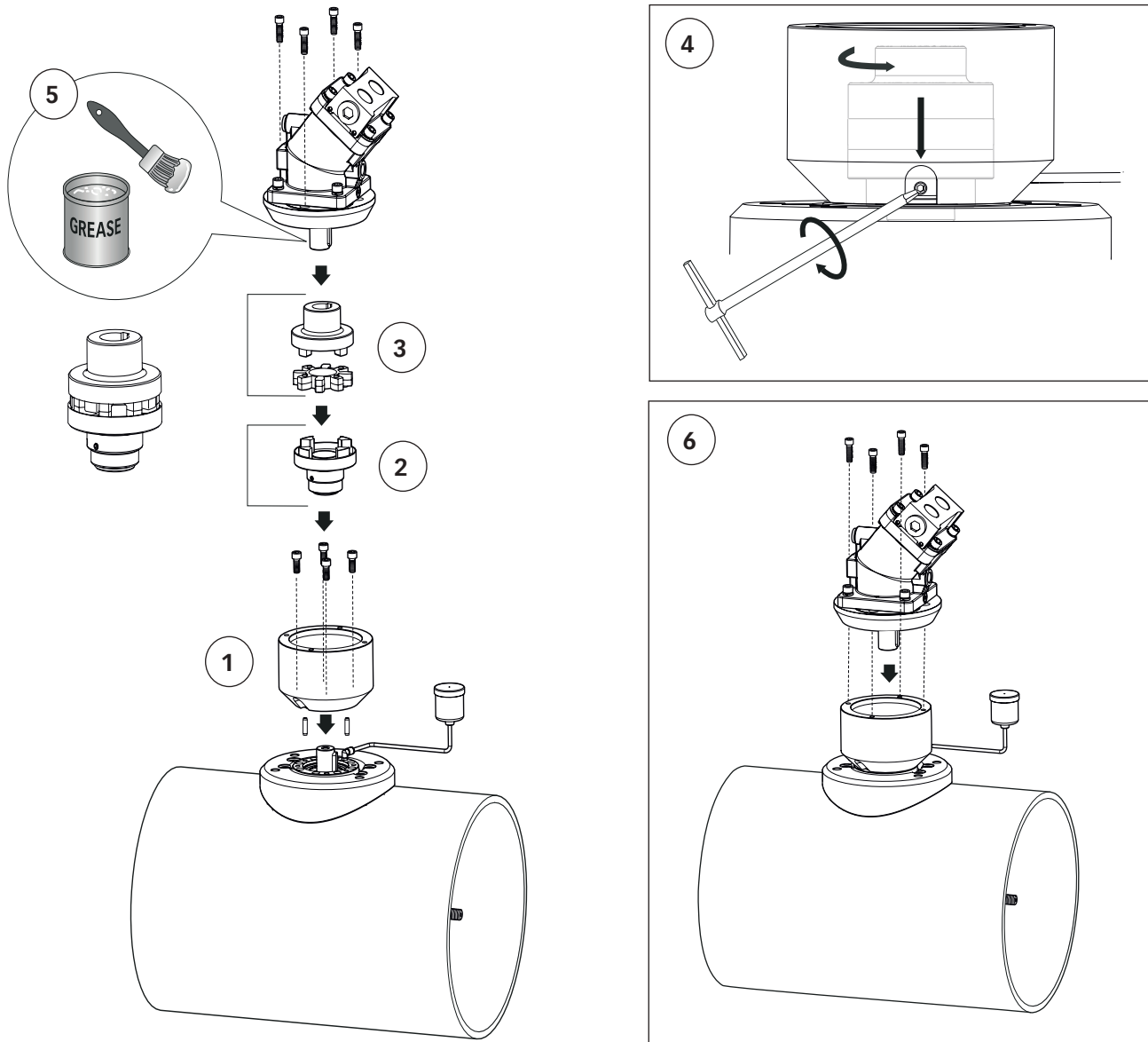

Procedure:

1. Secure the motor flange with the supplied screws and pins.
2. Insert the lower coupling half in the terminal part of the gearleg shaft.
3. Insert the cush drive damper and the upper coupling half onto the lower one.
4. Turn the coupling half to align the grub screw with the hole on the flange and tighten the grub screw of the coupling half.
5. Grease the terminal part of the drive shaft and insert the motor on the gearbox.
6. Secure the motor with the screws supplied with the flange

4.11 - BTH 513 motor/coupling assembly

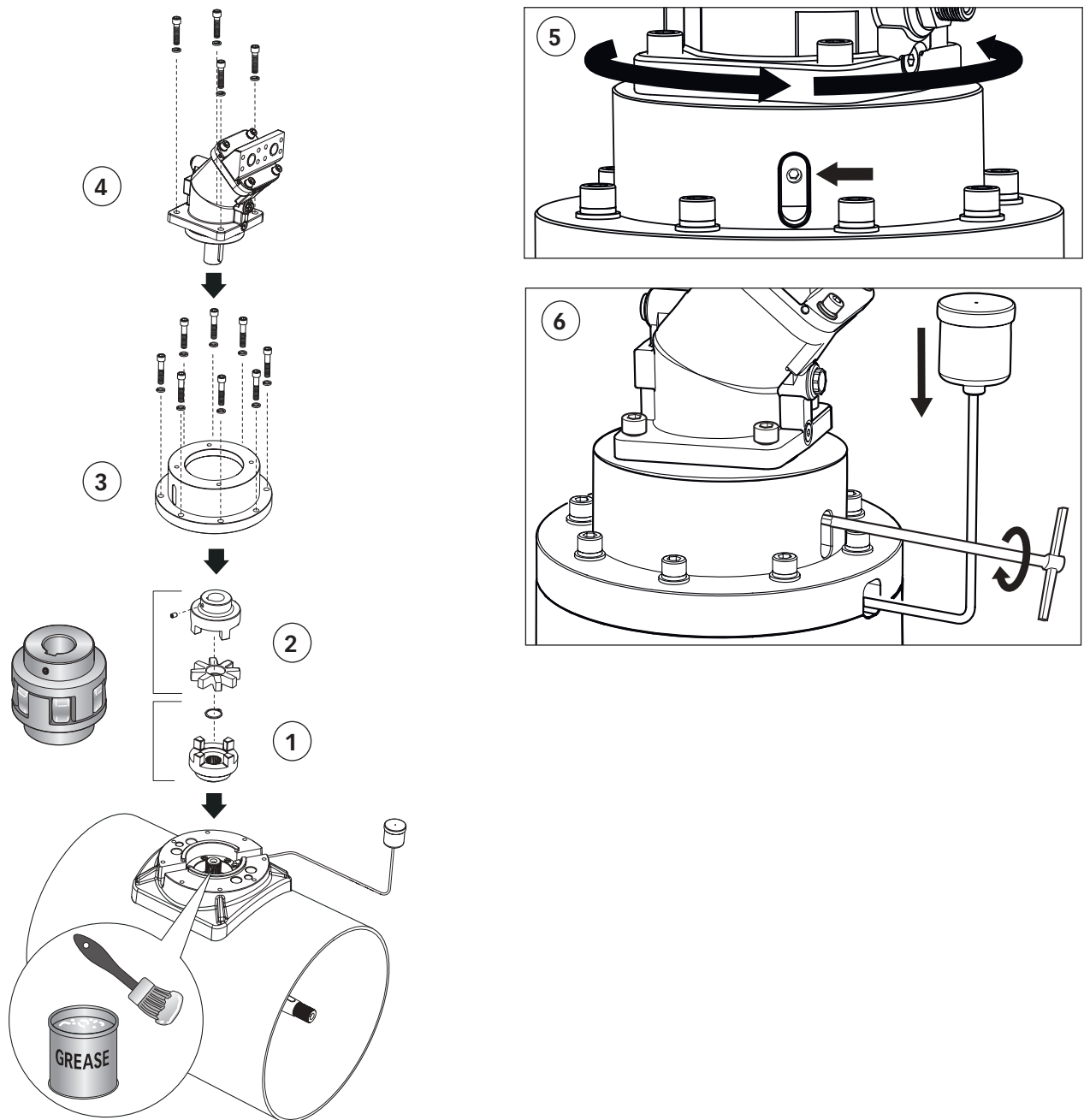
**Procedure:**

1. Grease the end of the gearbox, insert the lower coupling half and secure it with the snap ring.
2. Fit the cushion drive damper and the upper coupling half to the gearbox.
3. Secure the motor flange with the supplied screws and washers.
4. Place the motor on the elastic coupling.
5. Rotate the motor to align the coupling screw.
6. Tighten the screw of the coupling, holding it towards the gearbox. Turn the motor to the desired position and secure with the screws.



4.12 - Propeller assembly

Insert the drive keys **A** into the seats in the shafts of the gearleg **B**, assemble the propellers **C** onto the gearbox by engaging them to the drive keys **A**, secure the propellers with the self-locking nuts **D**, (and grub screws **E**, only for BTH 513). Secure the anodes **F** with screws **G** previously smeared with structural adhesive (such as Loctite).

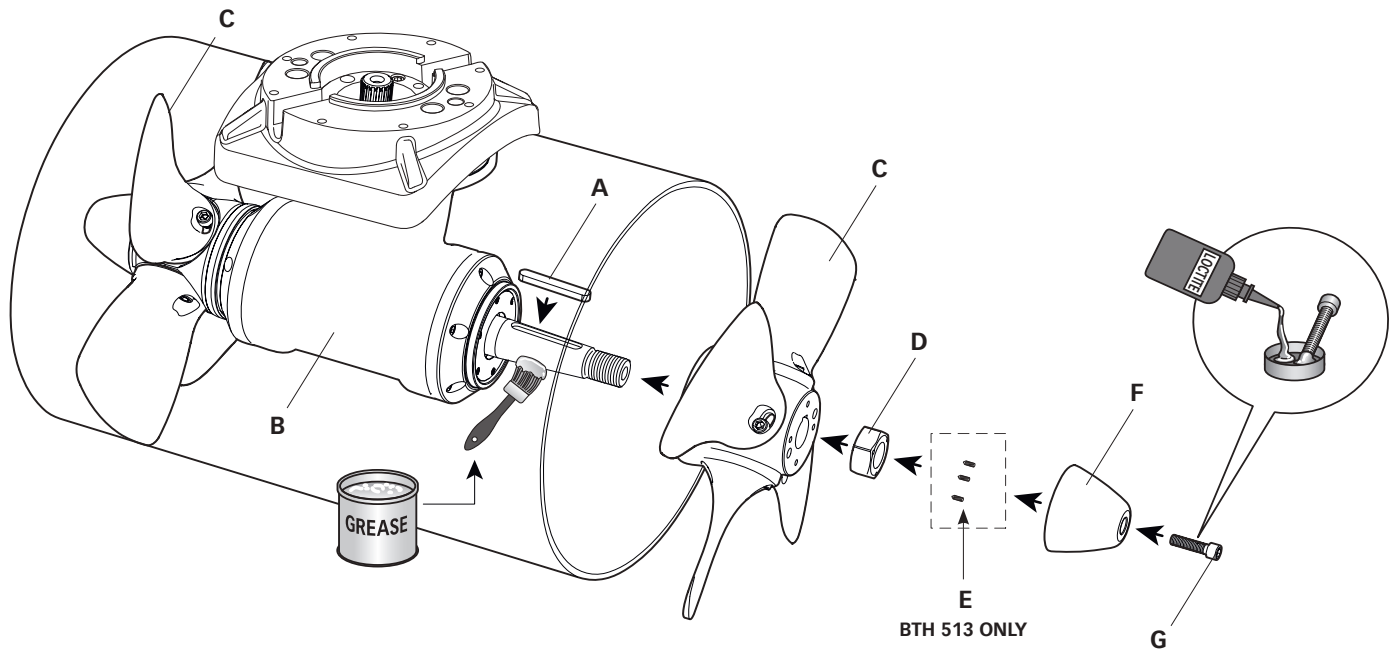

WARNING: on conclusion of assembly, make sure that the propeller is exactly positioned at the central point of the tunnel.

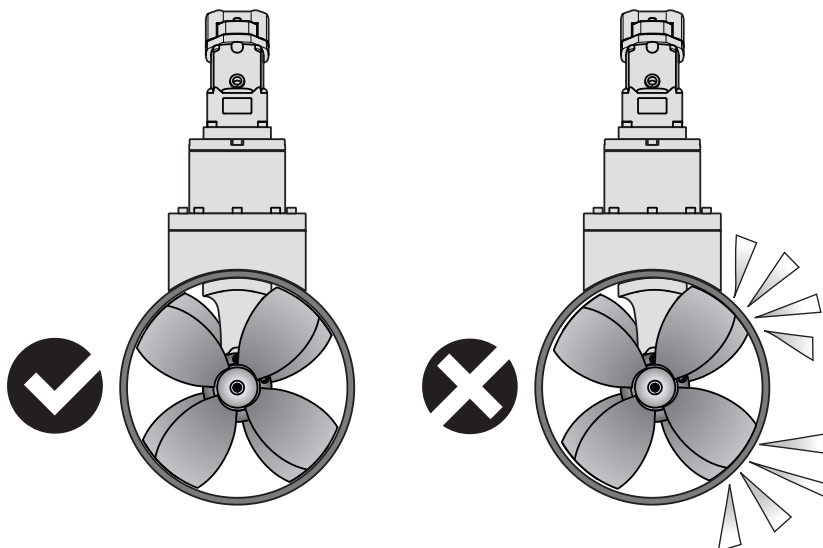

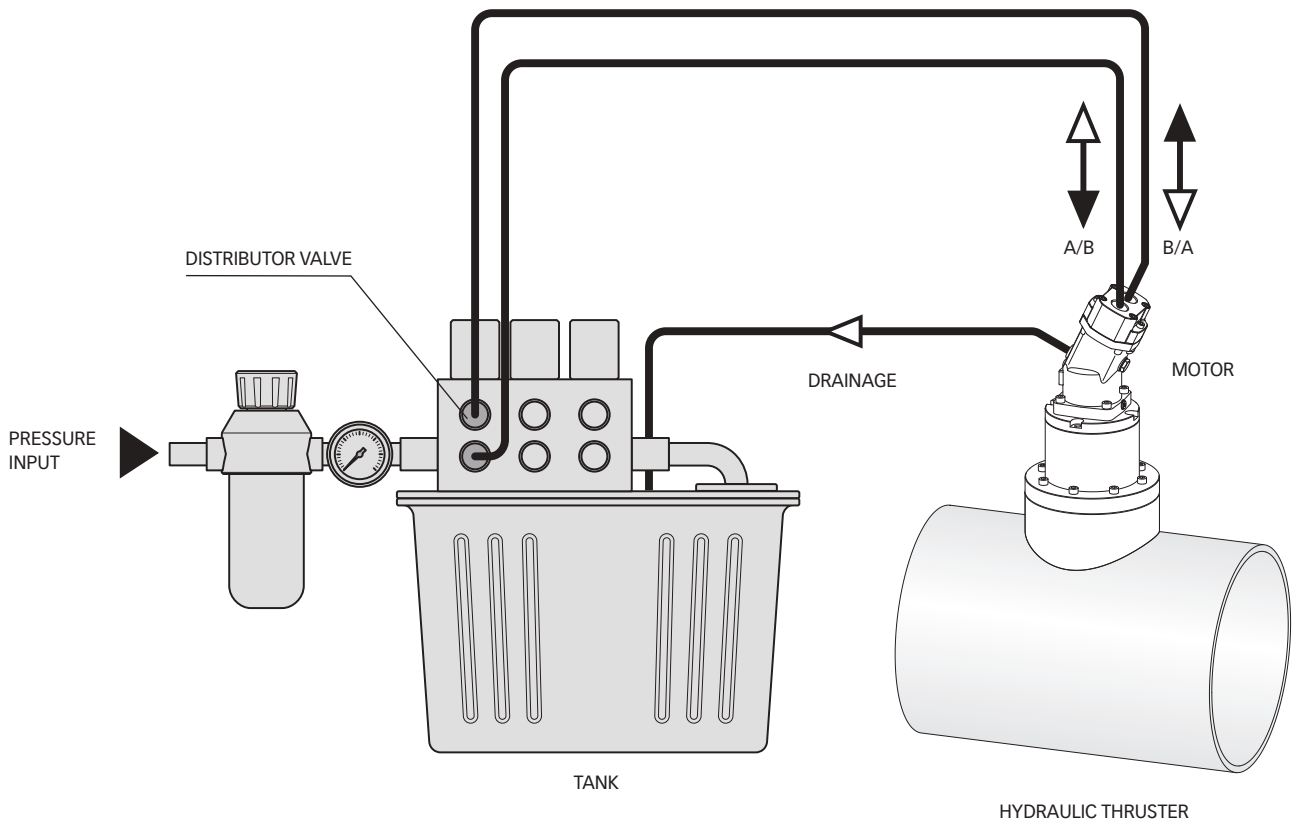

6.0 - Use

Start-up happens following activation of a Quick® control panel.
To use the thruster and install the control panel, refer to the specific control manual.

6.1 - Important cautions

- This thruster is not designed for continuous use. It is equipped with protections which limit its operation at a maximum time span, as reported on the controls' manual. It is strongly forbidden to bypass or modify such protections in order to increase the operating time span, lest voiding the warranty and thus lifting any responsibility from Quick®.
- Make sure no swimmers or floating objects are in the vicinity before switching on the motor.
- There must not be flammable materials in the peak or in the area where the thruster motor is.
- Do not operate the thruster out of the water for more than 10 seconds.
- During mooring, it is recommended not to leave in the water any free line, which may be sucked in by the propellers, thus leading them to break.

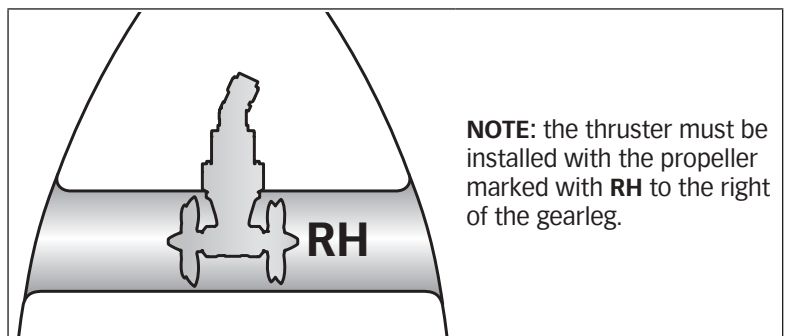
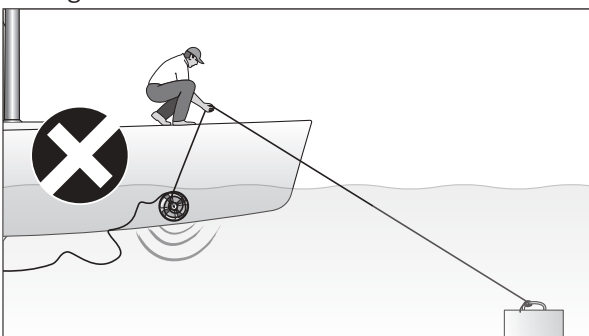



- The initial contamination level of the fluid used to fill the system should not exceed class 18/15 (ref. ISO 4406). This level should be maintained by adequate filtration, which is ensured by the system filter, according to the table.

Pressure	<140 bar	140÷210 bar	>210 bar
Class NAS 1638	10	9	8
Class ISO 4406	19/16	18/15	17/14
Ratio βx = 75	25-40 μm	12-15 μm	6-12 μm

- The system must have a filter to keep the oil free of impurities.
- It is advisable to install an exchanger or to use a well-dimensioned oil tank so that the maximum oil temperature remains within the range recommended for the hydraulic fluid used.
- We recommend the use of specific mineral oil-based fluids for hydraulic circuits, with good anti-wear and anti-foam characteristics, with fast deaeration, antioxidant, anti-corrosion, with lubricating properties and able to meet the requirements of DIN 51525 and VDMA 24317, with kinematic viscosity between 10cSt and 100cSt.
- Service temperatures must be between -10°C and +80°C.
- The entire hydraulic system is the responsibility of the installer who, according to the specifications described and the service requirements, must protect the motor from potential damage resulting from the system.
- The motor must not be used with pressures higher than those indicated.
- Higher values may irreparably compromise the integrity of the motor.
- Carefully follow Quick's instructions to obtain maximum efficiency from your product; with different settings, do not exceed the maximum pressure values indicated in the table.
- Under no circumstances should the maximum pressure in the drainage branch exceed 6 bar.
- The installation of a pressure relief valve (set to a value 10% - 15% higher than the maximum service pressure in the control valve) is recommended to protect the system from damage due to mechanical blockage of the system.
- It is recommended to install an electronic or hydraulic system that delays motor motion reversal in order to protect the gearbox from breaking down.

Quick® thrusters are made in materials that are resistant to the sea environment: in any case, it is indispensable to periodically remove deposits that form on the outer surfaces to avoid corrosions with consequent system inefficiency.

DEPENDING ON USE, PERIODICALLY CHECK THE TIGHTNESS OF THE OIL SEALS AND REPLACE THEM IF NECESSARY.



- Make sure that the power supply to the hydraulic motor is not switched on when maintenance operations are carried out.
- Do not paint the anodes, the sealings and the gearleg's shaft where the propellers are lodged.

Dismantle once a year, following the points below:

- Clean propellers, tunnel and gearleg.
- Replace the anodes (carry out this operation more often if needed).
- Replace the propellers if damaged or worn out.
- Check the tightness of all screws.
- Ensure that there is no water seepage inside.
- Check that all hydraulic connections are well tightened and oxide-free.

REMOVING THE GEARBOX FLANGE 386

- **FIG. A** Disassemble the various motor components (1 to 9).
- **FIG. B** To help separating the gearbox flange (10) from the tunnel, use 4 screws M12x100.

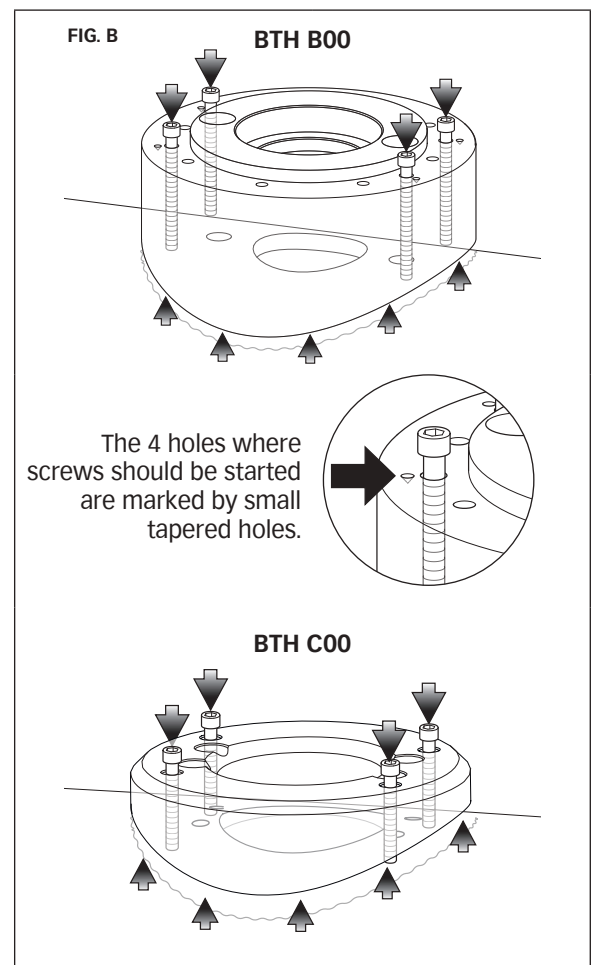
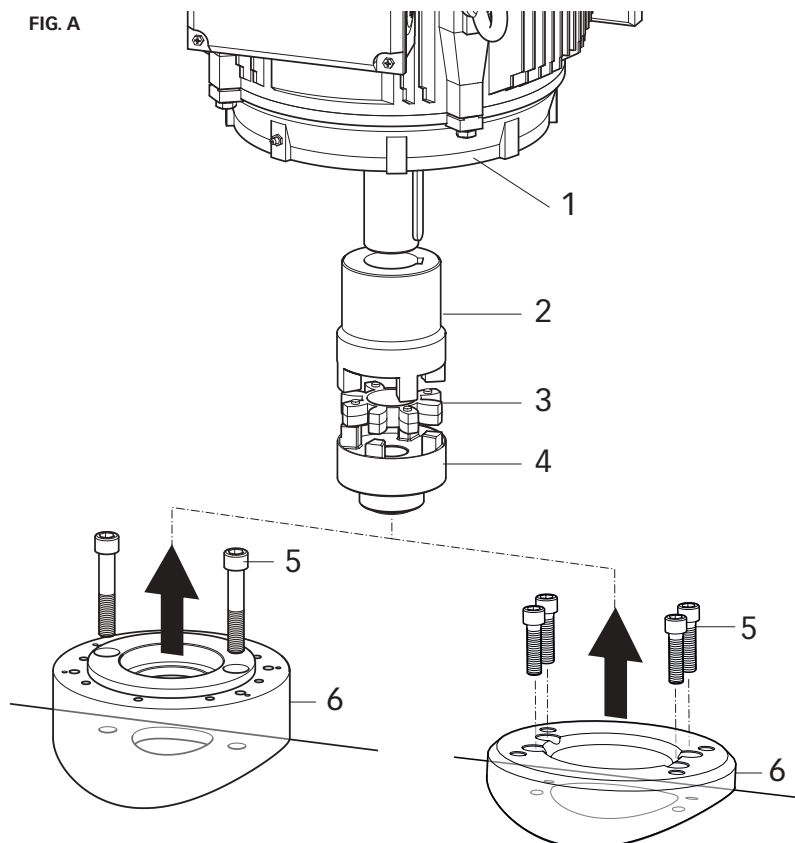



As with installation, at the end of this product life, dismantling must be carried out by qualified personnel.

This product is made up of various materials, some can be recycled and others must be suitably disposed of; enquire about the recycling or disposal systems provided for by local regulations for this product category.

Some parts of the product may contain pollutants or hazardous substances that, if dispersed, may be harmful to the environment and human health.



As indicated by the symbol on the side, it is forbidden to dispose of this product as domestic waste.

Separate the products for disposal in accordance with the regulations in force in your area or return the product to the seller when purchasing a new equivalent product.

Local regulations may impose severe penalties for the improper disposal of this product.

10.0 - BTH 185

BTH 185-85 6.4 kW
BTH 185-105 8 kW

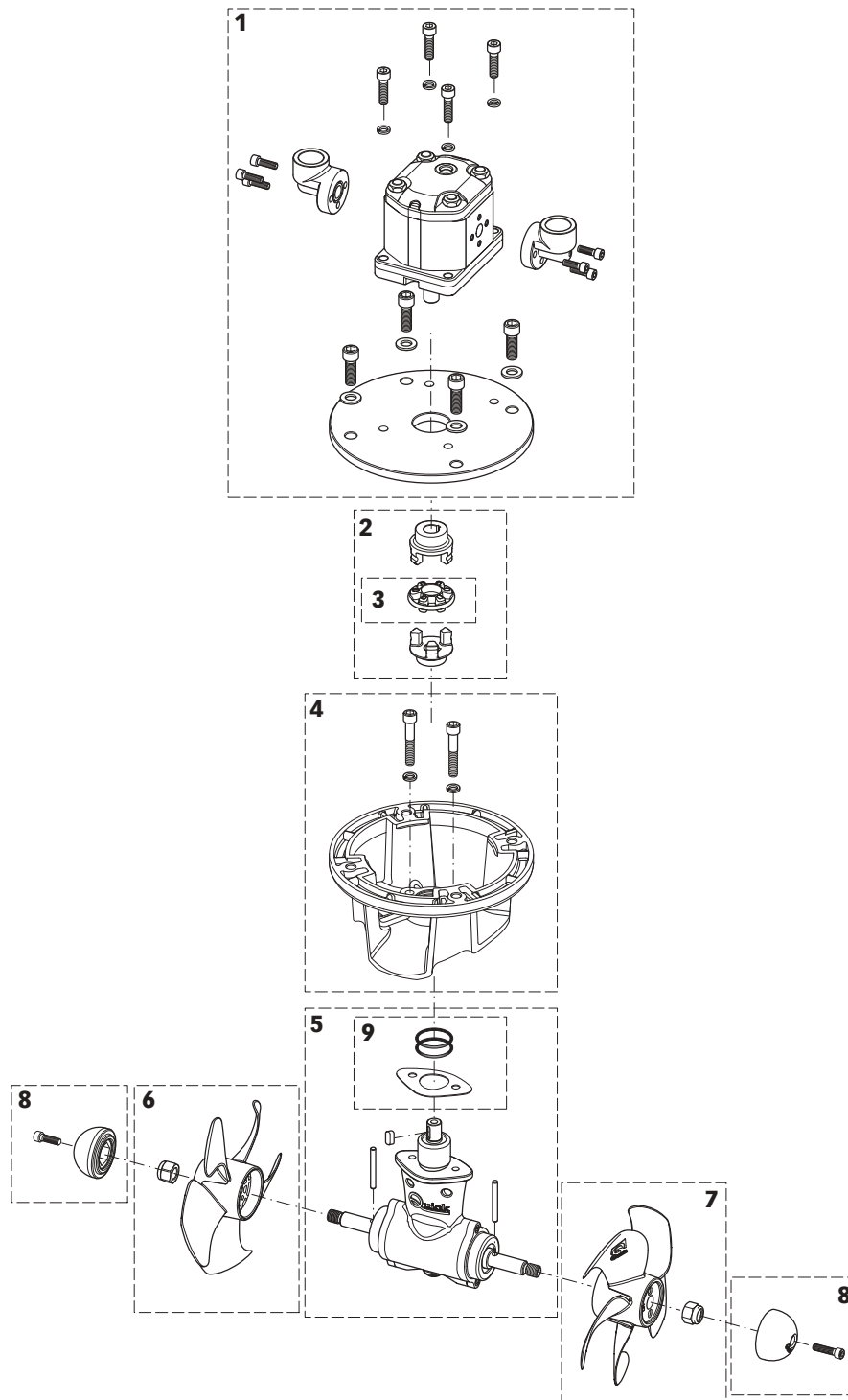

No.	DESCRIPTION	CODES		
1A	OSP GEAR MOTOR 4.5CC GR2 B5/90	FVEMFEL045B5090	4	OSP PROPELLER FLANGE KIT BTQ 185 FVSGFLBTQ185A00
1B	OSP GEAR MOTOR 6.4CC GR2 B5/90	FVEMFEL064B5090	5	OSP GEARBOX KIT BTQ185 DP FVSGGBT185DA00
2	OSP COUPLING KIT BTQ 185 HYDRO	FVSGG1851514H00	6	OSP PROPELLER KIT D185 LH FVSGEL185L00A00
3	OSP CUSH DRIVE DAMPER KIT D43 BT 140-185	FVSGGPVP4300A00	7	OSP PROPELLER KIT D185 RH FVSGEL185R00A00
			8	OSP PROPELLER ANODE KIT BTQ185 ALL FVSGANBTQ18AA00
			9	OSP GASKETS KIT BTQ185 FVSGGRNBT185A00



10.1 - BTH 250

BTH 250-150 9.2kW
BTH 250-220 11.2kW

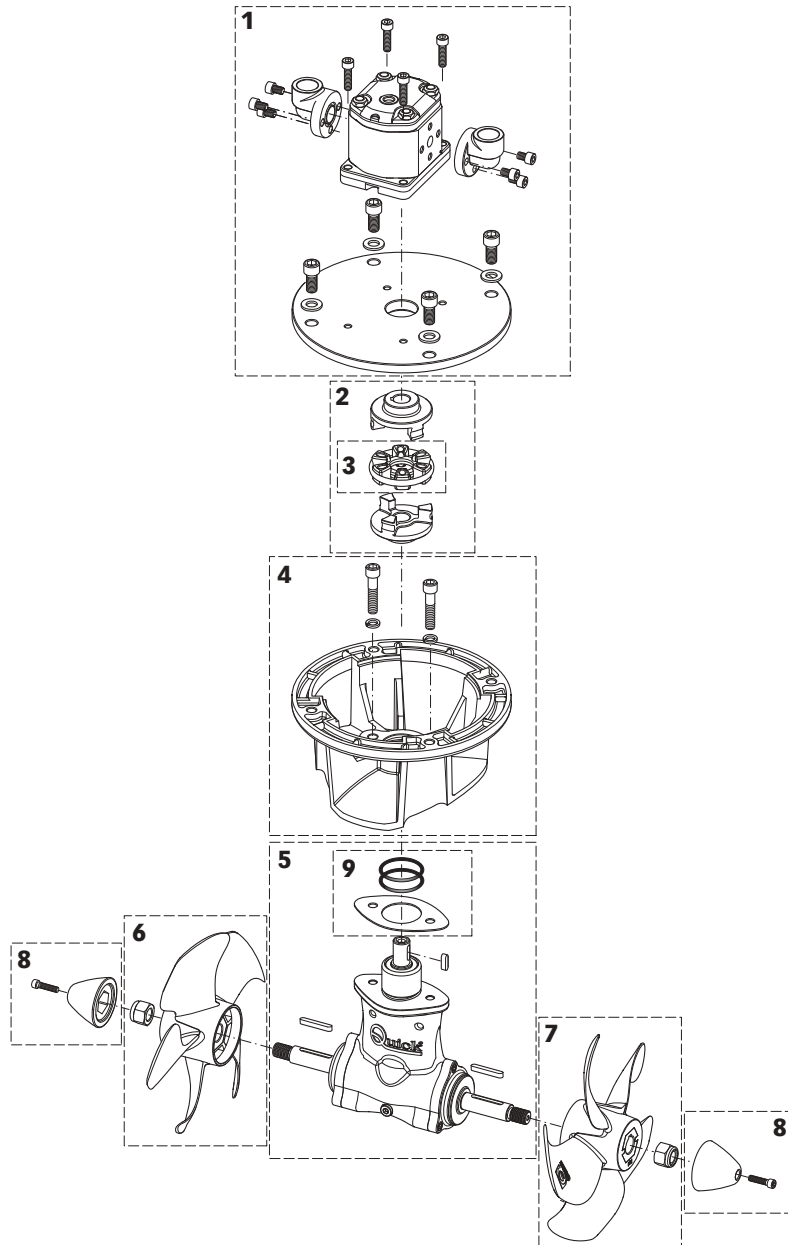

No.	DESCRIPTION	CODES		
1A	OSP GEAR MOTOR 9.6CC GR2 B5/100	FVEMFEL096B5100	4	OSP PROPELLER FLANGE KIT BT 250 FVSGGBT2500A00
1B	OSP GEAR MOTOR 14.1CC GR2 B5/100	FVEMFEL141B5100	5	OSP GEARBOX KIT BT 250 FVSGGBT2500A00
2	OSP COUPLING KIT BTQ 250 GEAR MOTOR	FVSGG250NGR0A00	6	OSP PROPELLER KIT D250 LH FVSGEL250L00A00
3	OSP CUSH DRIVE DAMPER KIT D70 BT 250-300	FVSGGPVP7000A00	7	OSP PROPELLER KIT D250 RH FVSGEL250R00A00
			8	OSP ANODES FOR PROPELLER KIT - BT 250 ALL FVSGANBTQ25AA00
			9	OSP GASKETS KIT BTQ250 FVSGGRNBT250A00



10.2 - BTH 300

BTH 300-240 15,5kW
 BTH 300-300 20,0kW
 BTH 300-400 24,0kW

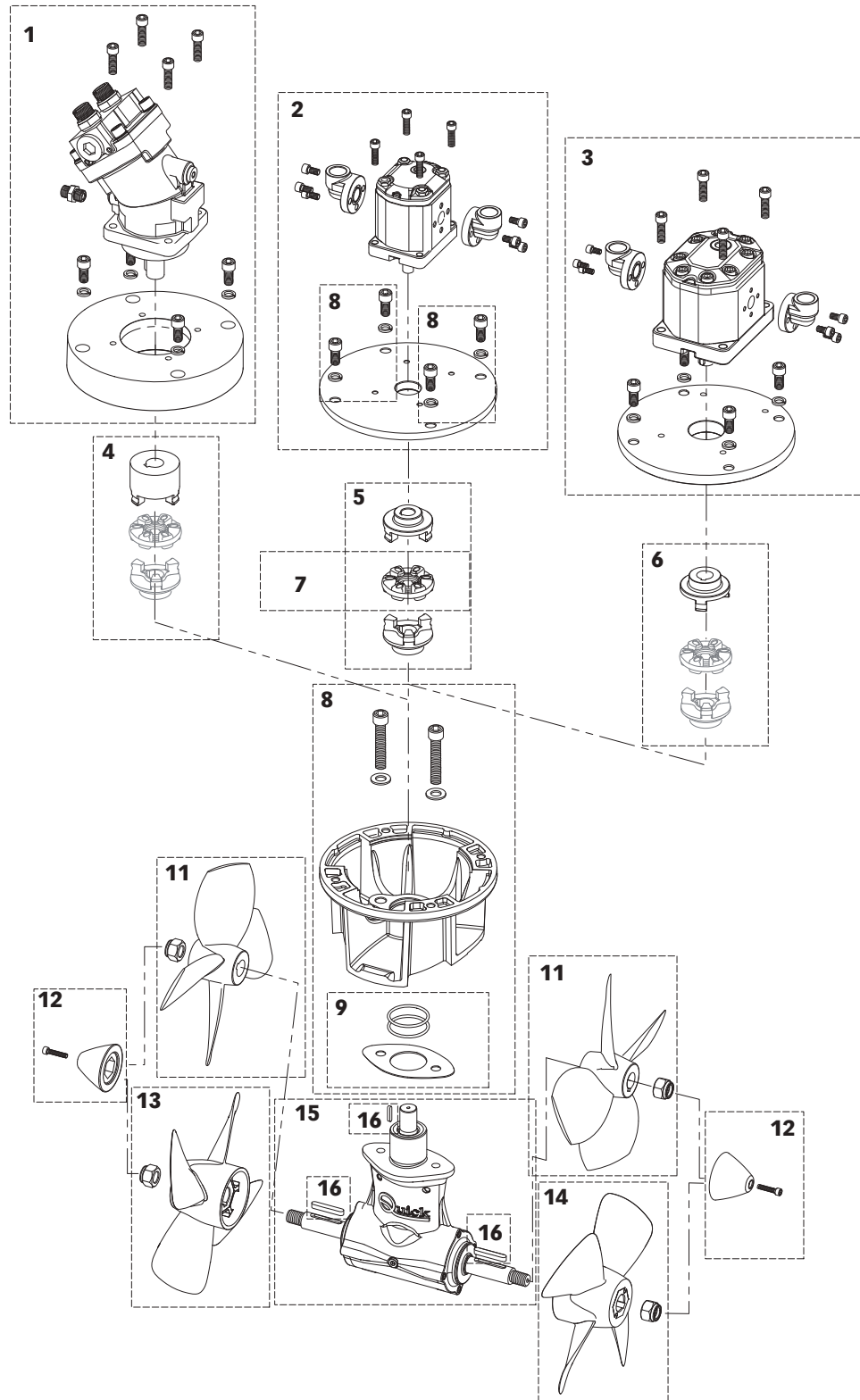

No.	DESCRIPTION	CODES			
1	OSP PISTON MOTOR 32CC BIDIRECT	FVEMFEL30PB5100	9	OSP GASKETS KIT BTQ 300	FVSGGRNBT300A00
2	OSP GEAR MOTOR 17.9CC GR2 B5/100	FVEMFEL179B5100	10	OSP GEARBOX KIT BT 300	FVSGGBT3000A00
3	OSP GEAR MOTOR 22CC GR3 B5/100	FVEMFEL220B5100	11	OSP PROPELLER KIT D300 LH NIBRAL	FVSGEL300N00A00
4	OSP COUPLING KIT BTH 300 HYDRO PISTONS	FVSGG300PST0A00	12	OSP PROPELLER KIT D300 RH NIBRAL	FVSGEL300R00A00
5	OSP COUPLING KIT BTH 300 HYDRO 300-240	FVSGG300NGR0A00	13	OSP PROPELLER KIT D300 LH NYLON	FVSGEL300L00A00
6	OSP COUPLING KIT BTH 300 HYDRO 300-300	FVSGG300NRG2A00	14	OSP PROPELLER KIT D300 RH NYLON	FVSGEL300R00A00
7	OSP CUSH DRIVE DAMPER KIT D70 BT 250-300	FVSGGPVP7000A00	15	OSP ANODES FOR PROPELLER KIT - BT 300 ALL	FVSGANBTQ300A00
8	OSP PROPELLER FLANGE KIT BT 300	FVSGFLBTQ300A00	16	OSP GEARBOX KEYS KIT BTQ 300	FVSHBTQ300A00



10.3 - BTH 386

BTH 386-420 34.0KW
BTH 386-455 34.0KW

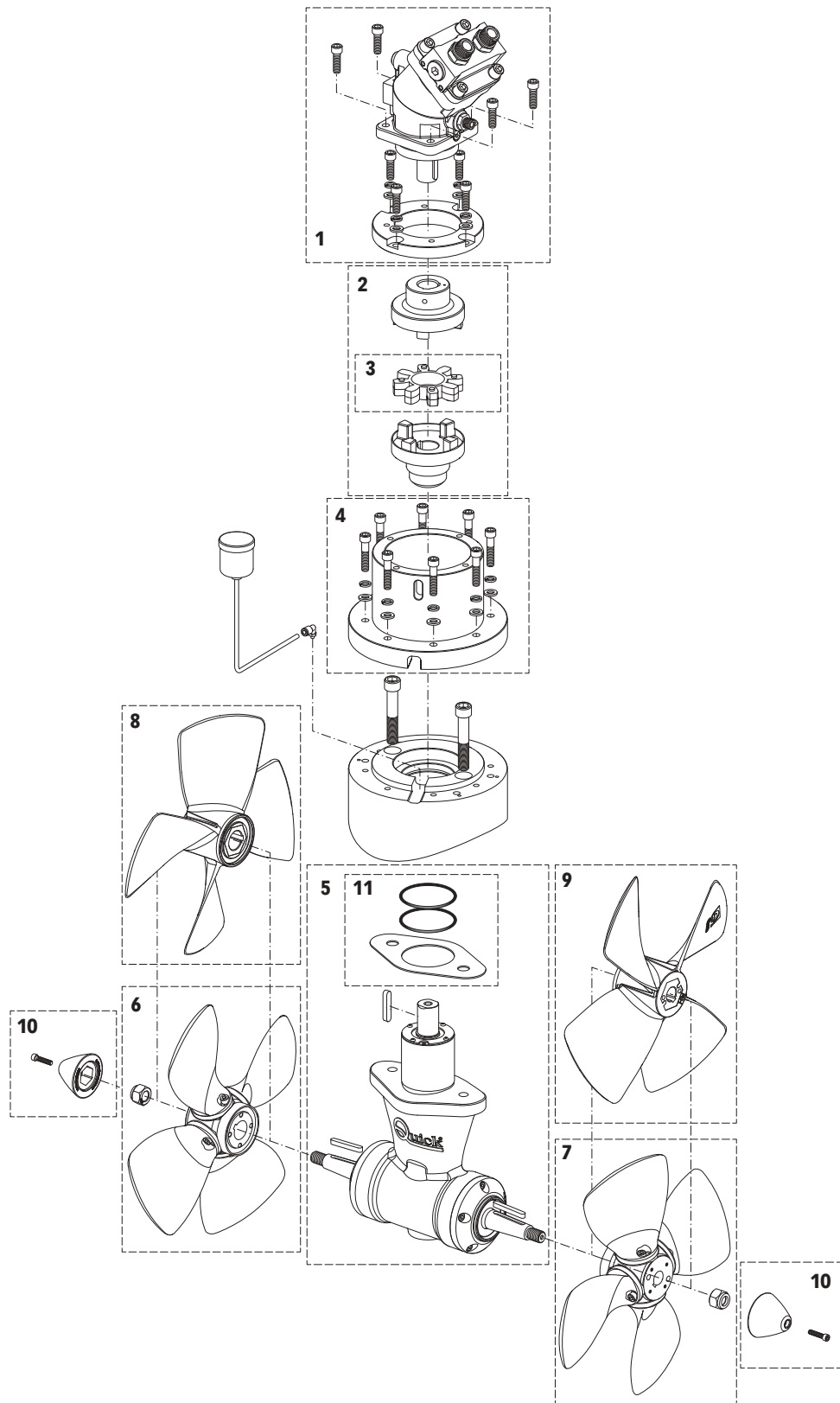

No.	DESCRIPTION	CODES		
1	OSP PISTON MOTOR 41CC BIDIRECT	FVEMFEL41P386A0	6	OSP PROPELLER KIT D386L P480 COMPLETE FVSGEL386L30A00
2	OSP COUPLING KIT BTQ 386 HYDRO	FVSGG3863235H00	7	OSP PROPELLER KIT D386R P480 COMPLETE FVSGEL386R30A00
3	OSP CUSH DRIVE DAMPER KIT (BLACK) B00	FVSGGPVP109BA00	8	OSP PROPELLER KIT D386L NYLON COMPLETE FVSGEL386L3PA00
4	OSP PROPELLER FLANGE KIT BTH386 41CC B00	FVSGFLBTH386B00	9	OSP PROPELLER KIT D386R NYLON COMPLETE FVSGEL386R3PA00
5	OSP GEARBOX KIT BTQ386 B00	FVSGGBBT3860B00	10	OSP ANODES FOR PROPELLER KIT - BT 386 ALL FVSGANBTQ38AA00
			11	OSP GASKETS KIT BTQ 386 FVSGGRNBT386A00

10.4 - BTH 386 HD

BTH 386-455HD 34.0KW

BTH 386-550HD 41.0KW

BTH 386-580HD 41.0KW

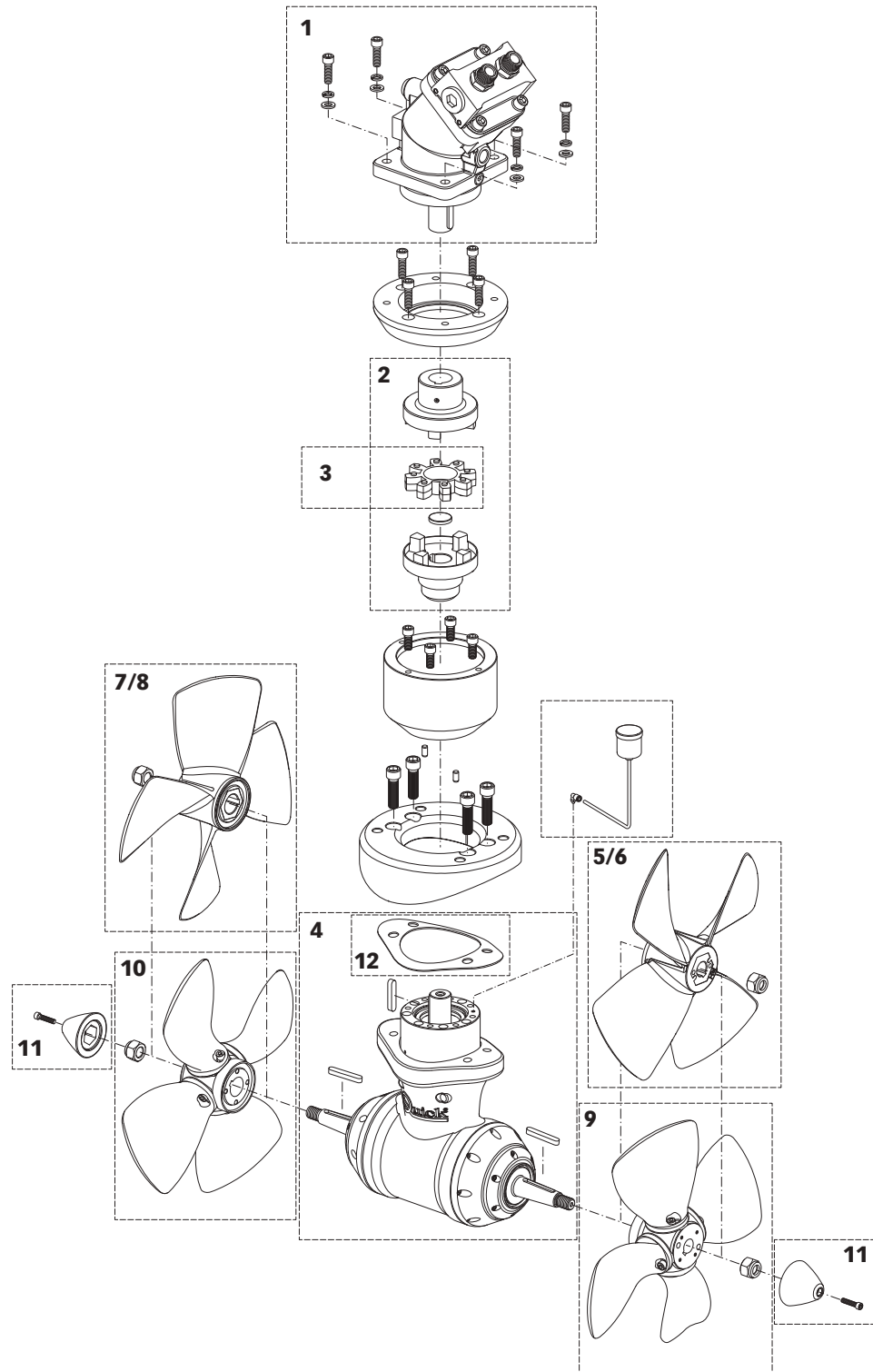

No.	DESCRIPTION	CODES		
1A	OSP PISTON MOTOR 41CC BIDIRECT	FVEMFEL41P386A0	6	OSP PROPELLER KIT D386L P600 COMPLETE FVSGEL386L40A00
1B	OSP PISTON MOTOR 55CC BIDIRECT	FVEMFEL55P386A0	7	OSP PROPELLER KIT D386R P480 COMPLETE FVSGEL386R30A00
2A	OSP COUPLING KIT BTQ 386-455 HYDRO	FVSGG3863235H00	8	OSP PROPELLER KIT D386R P600 COMPLETE FVSGEL386R40A00
2B	OSP COUPLING KIT BTQ 386-580 HYDRO	FVSGG3863255H00	9	OSP PROPELLER KIT D386L NYLON COMPLETE FVSGEL386L3PA00
3	OSP CUSH DRIVE DAMPER KIT D109 BT 386 HD	FVSGGPVP1090A00	10	OSP PROPELLER KIT D386R NYLON COMPLETE FVSGEL386R3PA00
4	OSP GEARBOX KIT BT 386 HD	FVSGGBBT3862A00	11	OSP ANODES FOR PROPELLER KIT - BT 300 ALL FVSGANBTQ30AA00
5	OSP PROPELLER KIT D386L P480 COMPLETE	FVSGEL386L30A00	12	OSP GASKETS KIT BT 386 R2 FVSGGRBT3862A00



10.5 - BTH 513

BTH 513-1000 60KW

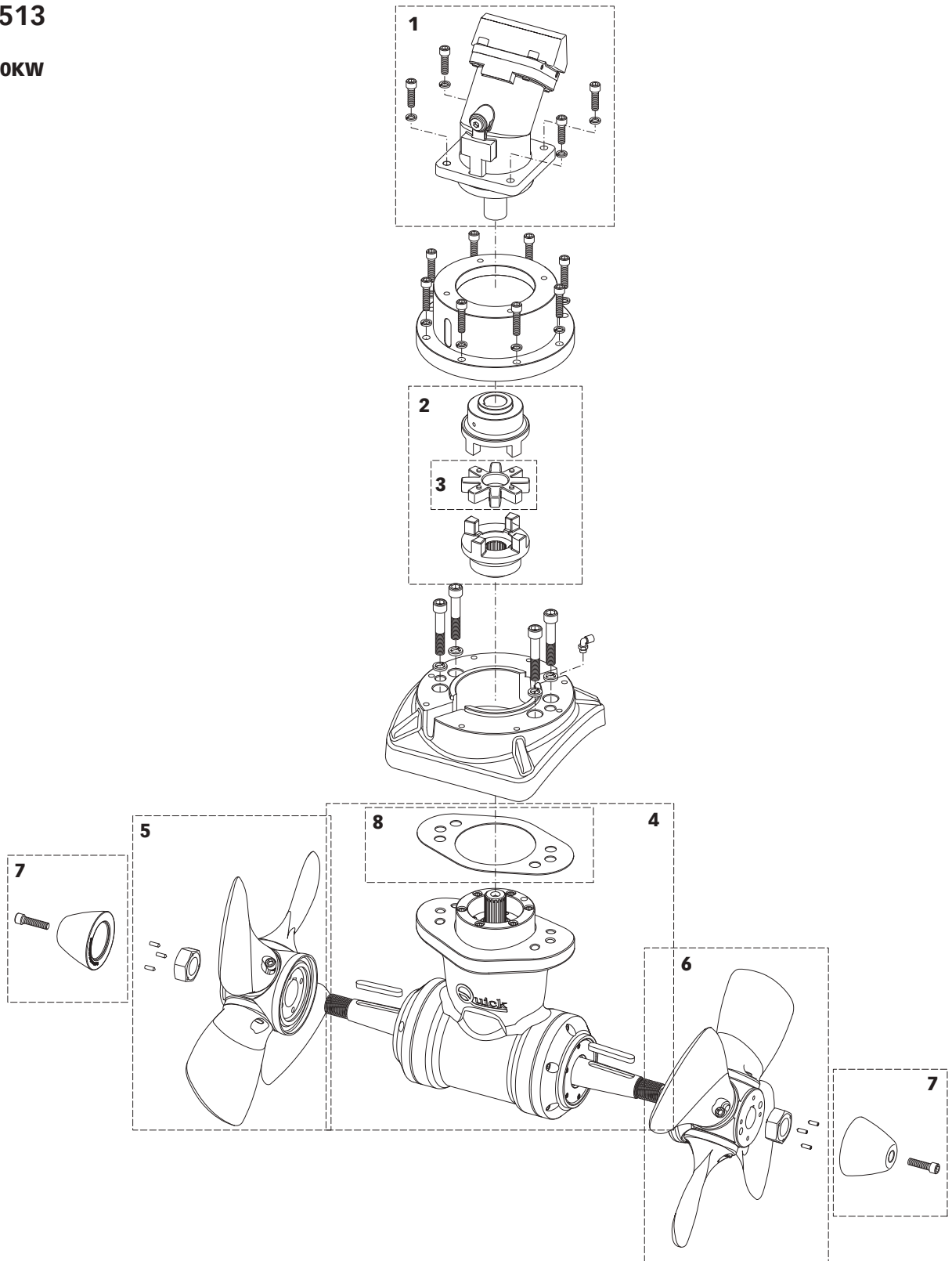

No.	DESCRIPTION	CODES	5	OSP PROPELLER KIT D513R P480	FVSGEL513R30A00
1	OSP PISTON MOTOR 90CC BIDIRECT	FVEMFEL90P513A0	6	OSP PROPELLER KIT D513L P480	FVSGEL513L30A00
2	OSP COUPLING KIT BTQ 513 HYDRO	FVSGG5131000H00	7	OSP ANODES FOR PROPELLER KIT - BT 513 ALL	FVSGANBTQ51AA00
3	OSP CUSH DRIVE DAMPER KIT D120 BT 513	FVSGGPVP1200A00	8	OSP GASKET KIT BTQ513	FVSGGRNBT513A00
4	OSP GEARBOX KIT BT 513	FVSGGBBT513A00			



BTH 185-85 **BTH 250-220**
BTH 185-105 **BTH 300-240**
BTH 250-150 **BTH 300-300**

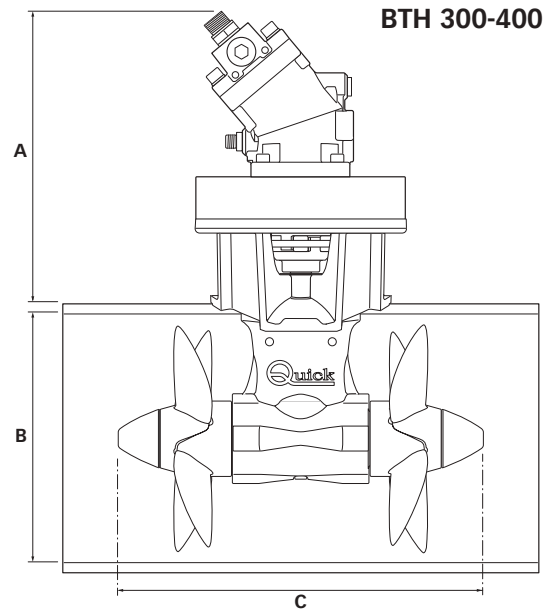
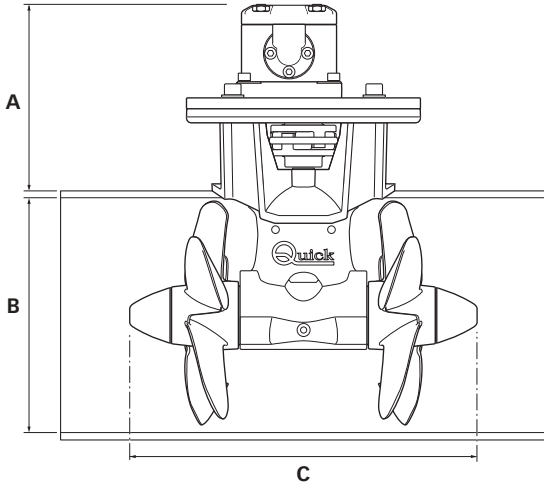

	BTH 185-85	BTH185-105	BTH 250-150	BTH 250-220	BTH 300-240	BTH 300-300	BTH 300-400
A	173.5	176	691 (27 13/64)	209	228	246	345
B	185	185	250 (98 27/64)	250	300	300	300
C	268 (105 33/64)	268 (105 33/64)	373 (14 11/16)	371	434	434	434

BTH 386-420
BTH 386-455

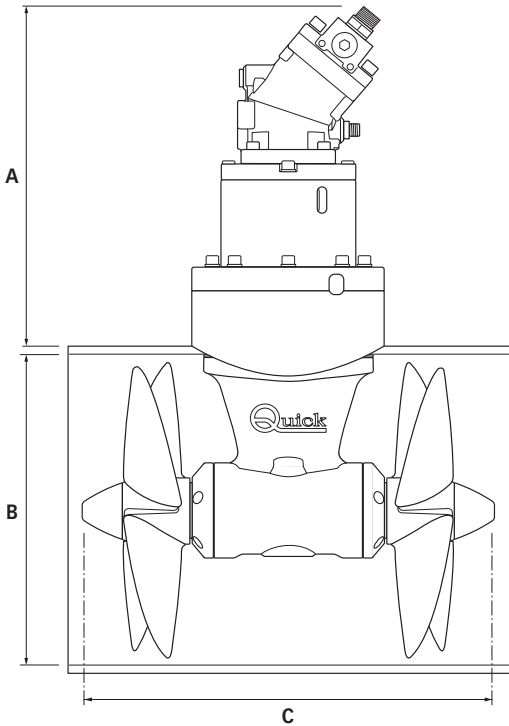

BTH 386-455 HD
BTH 386-550 HD
BTH 386-580 HD

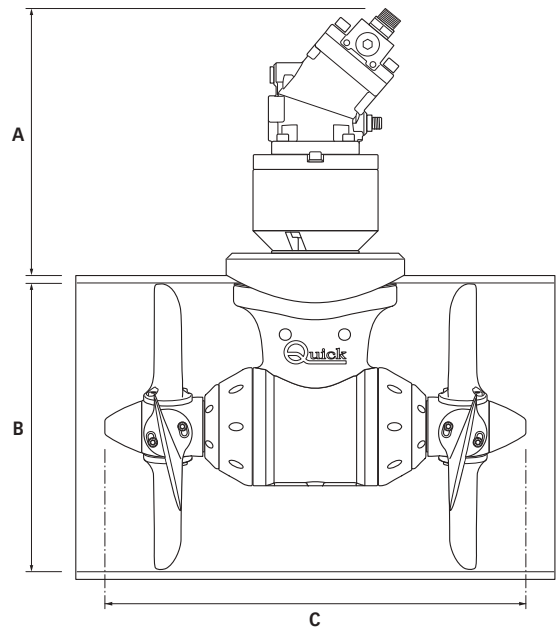

	BTH 386-420	BTH 386-455	BTH 386-455 HD	BTH 386-550 HD	BTH 386-580 HD
A	445	426	445	358	399
B	386	386	386	386	386
C	508	508	566	566	566



BTH 513-1000

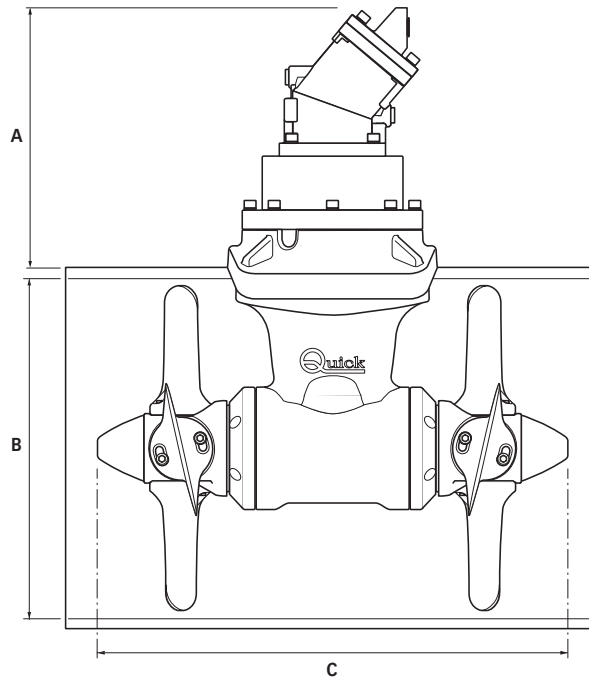

BTH 513-1000	
A	405
B	513
C	738

BTH Series

REV 001B



BTH 18585 - 185105

BTH 250150 - 250220

BTH 300240 - 300300 - 300400

BTH 386420 - 386455 - 386455HD - 386550HD - 386580 HD

BTH 5131000

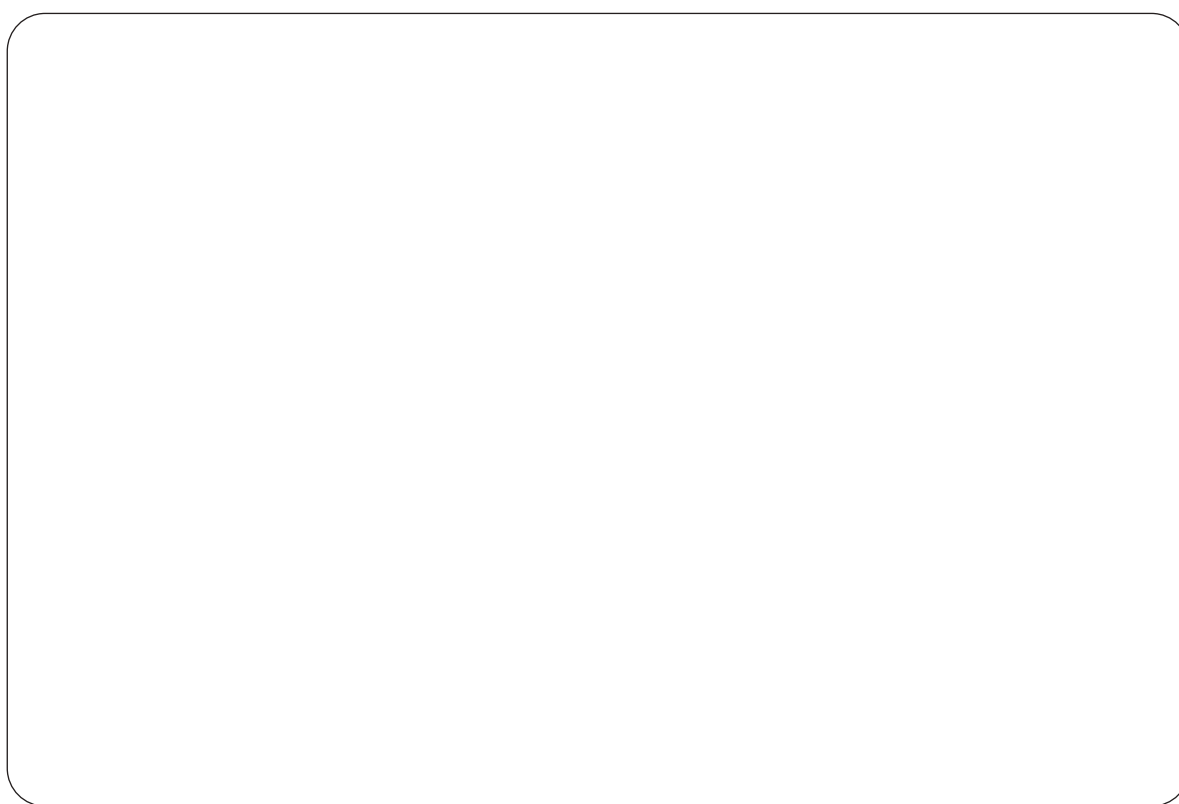

Product serial number

