

N4.115

SPECIFICATIONS

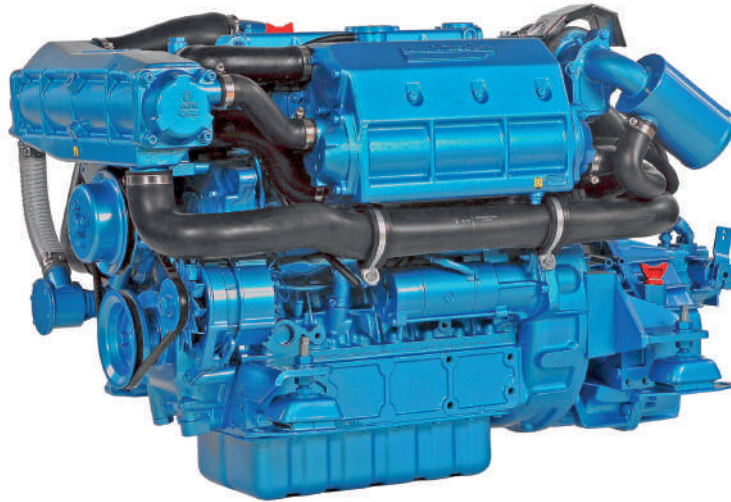

Power at crankshaft	84.6 kW [115 hp]	Engine base	Kubota
Displacement	3.769 l [230 in³]	Fuel system	Mechanical Direct injection
Configuration	4 cylinders in line	Air intake	Turbocharged with intercooler
Operation type	4 strokes Diesel	Cooling	Closed cooling with heat exchanger
Bore & Stroke	100 x 120 mm [3.94 x 4.72 in]	Max mounting angle	7° Front down 7° Front up
Compression ratio	19.1 : 1	Alternator	12 Volt 120 Amp
Rated speed	2600 rpm	Rating	M4
Idling speed	825 rpm	Emission compliance	RCD 2013/53/EU EPA marine Tier 3 BSO 2
Peak torque	387 Nm	Dry weight with TM345A	378 kg [833 lbs]
Peak torque speed	1600 rpm		

N4.115

84.6 kW [115 hp] at 2600 rpm

TECHNICAL DESCRIPTION

ENGINE BLOCK

- 4 Cylinders in line
- 4 Valves per cylinder
- Gear driven valve train
- Watercooled exhaust manifold

FUEL SYSTEM

- Mechanical governor
- Cam driven in-line injection pump
- Fuel feed pump
- Fuel filter with hand primer

LUBRICATION SYSTEM

- Replaceable full-flow oil filter
- Oil dipstick
- Oil drain pump

COOLING SYSTEM

- Closed cooling with heat exchanger
- Gear driven self-priming raw water pump
- Coolant circulating pump
- Water cooled exhaust elbow

ELECTRICAL SYSTEM & INSTRUMENTATION

- 12 V Electrical system
- 12 V / 120 A alternator
- Electric starter motor
- Electric stop function
- Instrumentation panel, including Start/ Stop, tachometer, coolant temperature & oil pressure indicators, alarms
- Extension cable harness with plug-and-play

AIR INTAKE

- Turbocharged with intercooler
- Mounted air cleaner

OTHER FEATURES

- Flexible engine mounting
- Bracket for control cables

OPTIONAL EQUIPMENTS & ACCESSORIES

- Keel cooling adaptation
- Complete marine propulsion systems
- Throttle and shift controls
- Additional instrumentation, Flying bridge extension harness
- Alternator 24 V - 55 A
- 24 V Electrical system
- Engine mounting adaptation
- Two pole electrical system
- Complete exhaust systems
- Trolling valve

RATINGS

- Up to 3000 annual operating hours
- Load factor up to 40%
- Full power for no more than 1 hour out of each 12 hours of operation. The remaining time must be at, or below cruising speed

TRANSMISSIONS

SHAFT LINE

- TM345 - TM345A
- TTM40A
- TTMC5A
- ZF25 - ZF25A26
- ZF45A
- Contact your local Nanni dealer for more details and availability for transmission model and type.

PERFORMANCE CURVES

POWER AT CRANKSHAFT

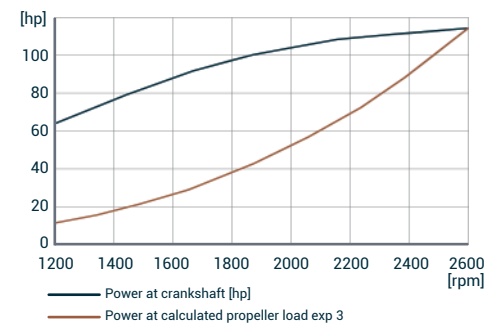

TORQUE AT CRANKSHAFT

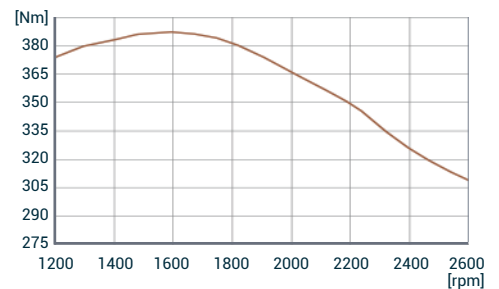

FUEL CONSUMPTION

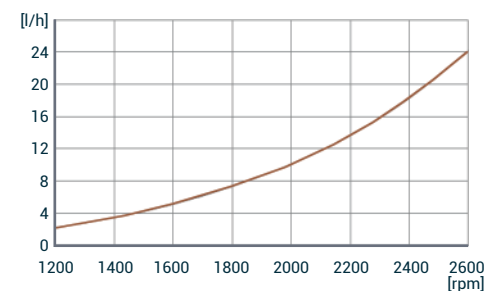

DIMENSIONS WITH TM345A

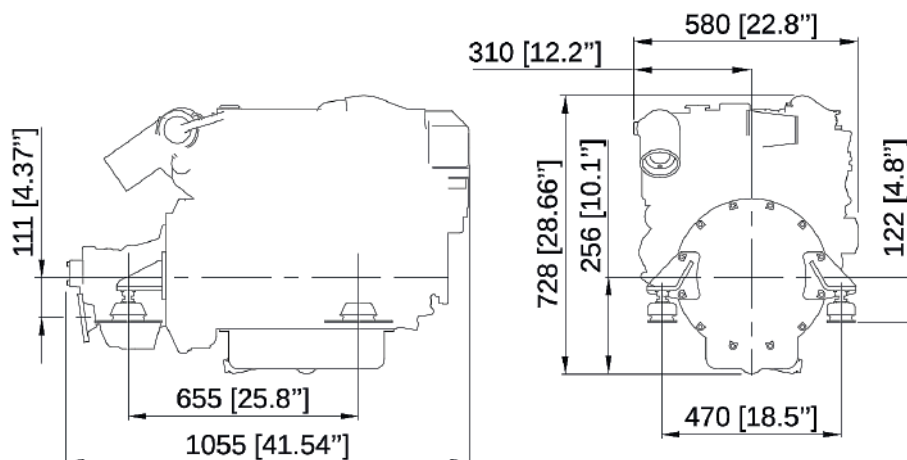

NANNI INDUSTRIES S.A.S.

11, Avenue Mariotte - Zone Industrielle
33260 La Teste - France
Tel: +33 (0)5 56 22 30 60
Fax: +33 (0)5 56 22 30 79

Technical data according to ISO 8665. This document is not contractual. Nanni reserves the right to modify any of the characteristics stated in this document without notice, in a constant effort to improve the quality of its products. Images and illustrations may show non standard equipments. All combination of equipment & accessory are not available.

DGBXXC01010