

USE M8 x 75 SOCKET HEAD CAP SCREWS FOR MOUNTING TO TRANSOM OR TRANSOM PLATE. DESIGN SCREW FORCE INCLUDING PRETENSION IS 19kN PER SCREW IN LOWER RAW. SCREW TORQUE TO APPLY IS 10 Nm.

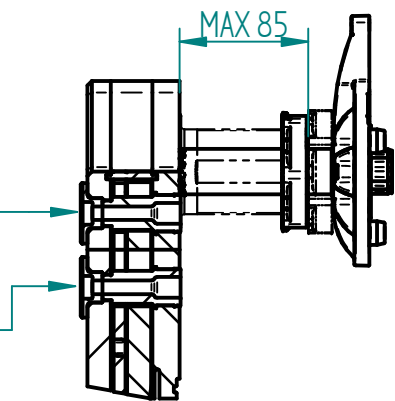

A-A

2	1	INTERCEPTOR H1450-M-00 DIMENSIONS	-		030030	
1	1	INTERCEPTOR H1450-P-00 DIMENSIONS	-		030031	
ITEM	QTY	DESCRIPTION	MATERIAL	SIZE	REFERENCE	REV
This document contains information of a proprietary nature and is delivered on the express condition that it is not to be disclosed, used or reproduced in whole or in part without the written consent of HUMPHREE AB.						
PROJECT				FILE NAME 031346-P01_H1450_PM_00_DIMENSIONS.dft		
TITLE INTERCEPTOR H1450-P/M-00 DIMENSIONS					CLIENT	
DRAWN JÖ		CHKD BH	APPVD CW	SCALE 15	DATE 2021-01-14	
HUMPHREE®		SIZE A3	DRAWING NO 031346	SHEET 1 OF 1	REV P01	
www.humphree.com						