

USE M8 x 75 SOCKET HEAD CAP SCREWS FOR MOUNTING TO TRANSOM OR TRANSOM PLATE. DESIGN SCREW FORCE INCLUDING PRETENSION IS 19kN PER SCREW IN LOWER RAW. SCREW TORQUE TO APPLY IS 10 Nm.

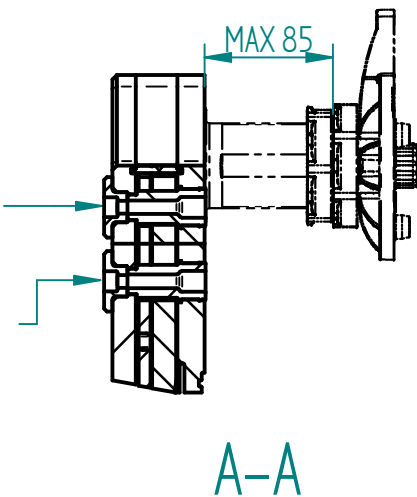

DATA

INTERCEPTOR SPAN
 INTERCEPTOR STROKE
 ENTRAINED WATER
 WEIGHT

800 mm
 50 mm
 8.3 Liter
 10.7 kg

2	1	INTERCEPTOR H0800-M-00 DIMENSIONS	-		030004	
1	1	INTERCEPTOR H0800-P-00 DIMENSIONS			030005	
ITEM	QTY	DESCRIPTION	MATERIAL	SIZE	REFERENCE	REV
This document contains information of a proprietary nature and is delivered on the express condition that it is not to be disclosed, used or reproduced in whole or in part without the written consent of HUMPHREE AB.						
PROJECT				FILE NAME 031333-P01_H0800-PM-00_DIMENSIONS.dft		
TITLE INTERCEPTOR H0800-PM-00 DIMENSIONS					CLIENT	
DRAWN JÖ		CHKD CW	APPVD CW	SCALE 15	DATE 2021-01-13	
HUMPHREE®		SIZE A3	DRAWING NO 031333	SHEET 1 OF 1	REV P01	
www.humphree.com						