

REV	DESCRIPTION	DATE	APPVD

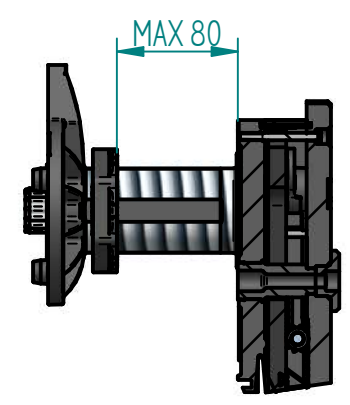
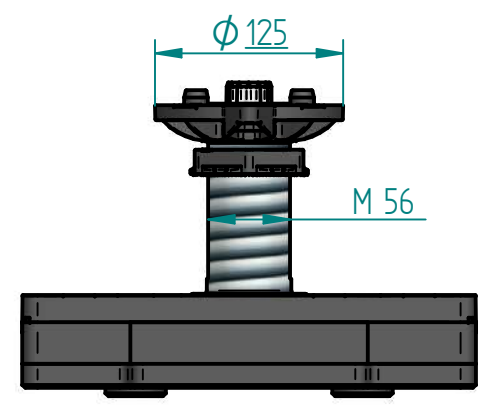
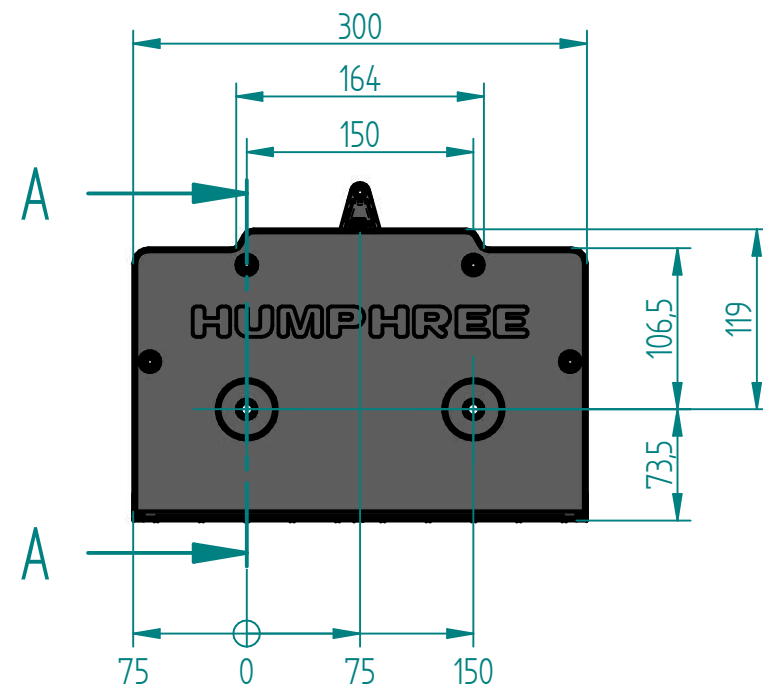
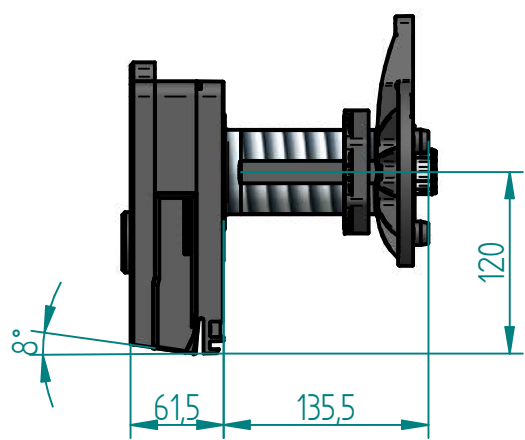

SECTION A-A

— USE M8 x 75 SOCKET HEAD CAP SCREWS FOR MOUNTING TO TRANSOM OR TRANSOM PLATE. DESIGN SCREW FORCE INCLUDING PRETENSION IS 19kN PER SCREW IN LOWER RAW. SCREW TORQUE TO APPLY IS 10 Nm.

ITEM	QTY	DESCRIPTION	MATERIAL	SIZE	REFERENCE	REV
This document contains information of a proprietary nature and is delivered on the express condition that it is not to be disclosed, used or reproduced in whole or in part without the written consent of HUMPHREE AB.						
PROJECT			FILE NAME 021379-P01_X300_SP_00_DIMENSIONS.dft			
TITLE INTERCEPTOR X300-SP-00 DIMENSIONS					CLIENT	
DRAWN JL		CHKD CW	APPVD CW	SCALE 15	DATE 2015-03-03	
HUMPHREE® www.humphree.com		SIZE A3	DRAWING NO 021379		SHEET 1 OF 1	REV P01